

# LVSM-130 Technical Information

Motor Parameters			LVSM-130-01				LVSM-130-02				LVSM-130-03				
Winding Type	Symbols	Units	A		B		A		B		A		B		
PERFORMANCE	DC Bus Voltage	V <sub>dc</sub>	24	48	24	48	24	48	24	48	24	48	24	48	
	Rated Power	P <sub>r</sub>	0.81	1.65	1.13	2.19	1.52	2.93	2.08	3.77	1.93	3.77	3.21	5.50	
	Stall Torque	T <sub>s</sub>	6.08	6.08	5.91	5.91	11.3	11.3	10.8	10.8	15.4	15.4	14.9	14.9	
	Rated Torque	T <sub>r</sub>	5.92	5.72	5.67	5.30	10.8	10.0	10.2	8.9	14.5	13.3	13.9	11.4	
	Peak Torque	T <sub>p</sub>	20.2	20.2	20.2	20.2	40.4	40.4	40.3	40.3	60.5	60.5	60.5	60.5	
	Rated Speed	N <sub>r</sub>	rpm	1300	2750	1900	3950	1350	2800	1950	4050	1275	2700	2200	4600
	No-Load Speed <sup>(2)</sup>	N <sub>no-load</sub>	rpm	1678	3357	2344	4688	1678	3350	2353	4688	1558	3117	2606	5212
	Torque Constant	K <sub>t</sub>	Nm/ A <sub>rms</sub>	0.17	0.17	0.12	0.12	0.17	0.17	0.12	0.12	0.18	0.18	0.11	0.11
	Voltage Constant <sup>(2)</sup>	K <sub>v</sub>	V <sub>rms</sub> /krpm	10.1	10.1	7.24	7.24	10.1	10.1	7.21	7.24	10.9	10.9	6.51	6.51
	ELECTRICAL	Stall Current	I <sub>s</sub>	36.7	36.7	49.9	49.9	67.9	67.9	90.7	90.7	86.7	86.7	139.7	139.7
Rated Current		I <sub>r</sub>	36.2	35.2	48.7	46.0	65.6	61.6	87.3	77.0	82.6	76.3	133.0	109.9	
Peak Current		I <sub>p</sub>	129	129	181	181	259	259	362	362	362	362	603	603	
Line Resistance <sup>(2)</sup>		R <sub>LL</sub>	mOhm	32.7 (±20%)	32.7 (±20%)	17.5 (±20%)	17.5 (±20%)	11.88 (±20%)	11.88 (±20%)	6.36 (±20%)	6.36 (±20%)	8.08 (±20%)	8.08 (±20%)	2.88 (±20%)	2.88 (±20%)
Line Inductance <sup>(2)</sup>		L <sub>LL</sub>	mH	0.20 (±30%)	0.20 (±30%)	0.10 (±30%)	0.10 (±30%)	0.10 (±30%)	0.10 (±30%)	0.05 (±30%)	0.05 (±30%)	0.07 (±30%)	0.07 (±30%)	0.03 (±30%)	0.03 (±30%)
Inertia (without brake)		J	kg.cm <sup>2</sup>	10.8	10.8	10.8	10.8	20.4	20.4	20.4	20.4	30	30	30	30
Weight (without brake)		W	kg	8.23	8.28	8.28	8.28	12.11	12.11	12.06	12.06	15.96	15.96	15.97	15.97
Thermal Resistance <sup>(2)</sup>		K <sub>therm</sub>	C°/W	1.46	1.14	1.34	0.93	1.10	0.83	0.99	0.63	0.97	0.69	0.81	0.50
Mech. Time Constant		K <sub>mech</sub>	ms	1.56	1.56	1.63	1.63	1.07	1.07	1.12	1.11	0.93	0.92	0.92	0.92
Motor Constant		K <sub>m</sub>	Nm/vW	0.76	0.78	0.75	0.79	1.29	1.37	1.26	1.43	1.70	1.84	1.71	2.06
FEEDBACK	Pole Number	n	10												
	Input Voltage	V <sub>rms</sub>	4												
	Frequency	kHz	5												
	Input Current	mA	26												
	Transformation Ratio		0.5±10%												
	Null Voltage	mV <sub>max</sub>	30												
	Phase Shift	Deg	-8°±2°												

1. All performance and electrical specifications are obtained at 25°C ambient and may change ±10%. 2. Rated data with reference aluminum plate 300mm x 408mm x 12mm (maximum winding temperature is 120°C). 3. Higher torque and speed values as well as dimensions on request.

# LVSM-130 Torque-Speed Curves

Tr: Rated Torque — @Tr 24V - - - @Tr 48V  
 Tp: Peak Torque — @Tp 24V - - - @Tp 48V

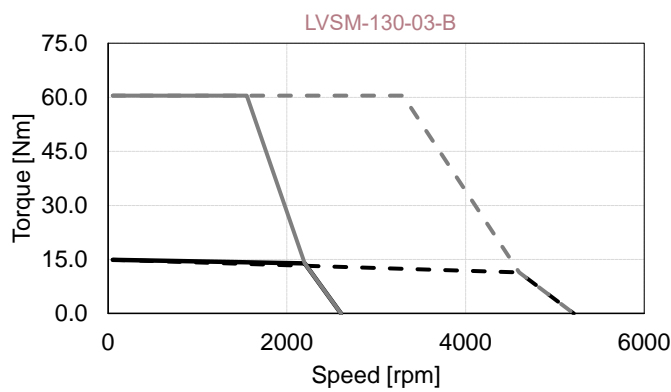
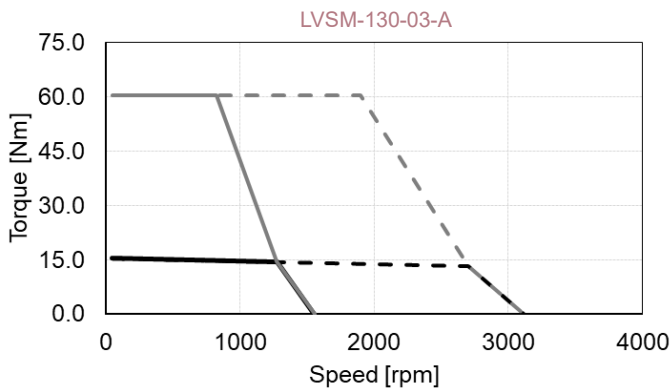
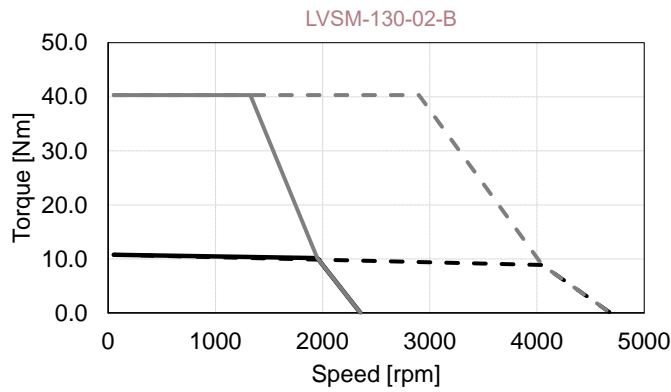
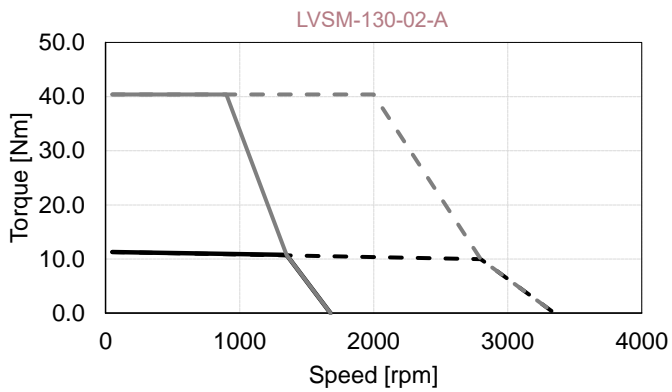
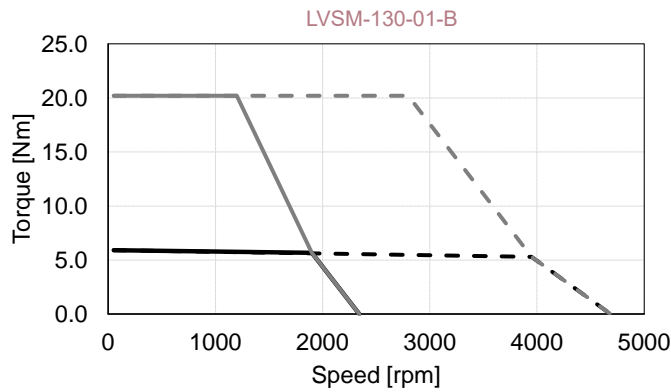
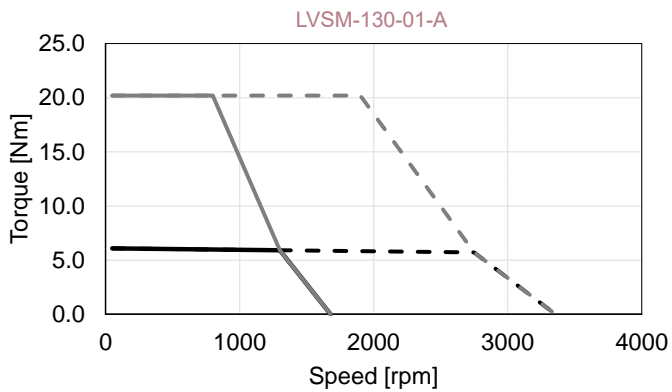

# LVSM-130 Outline Drawing

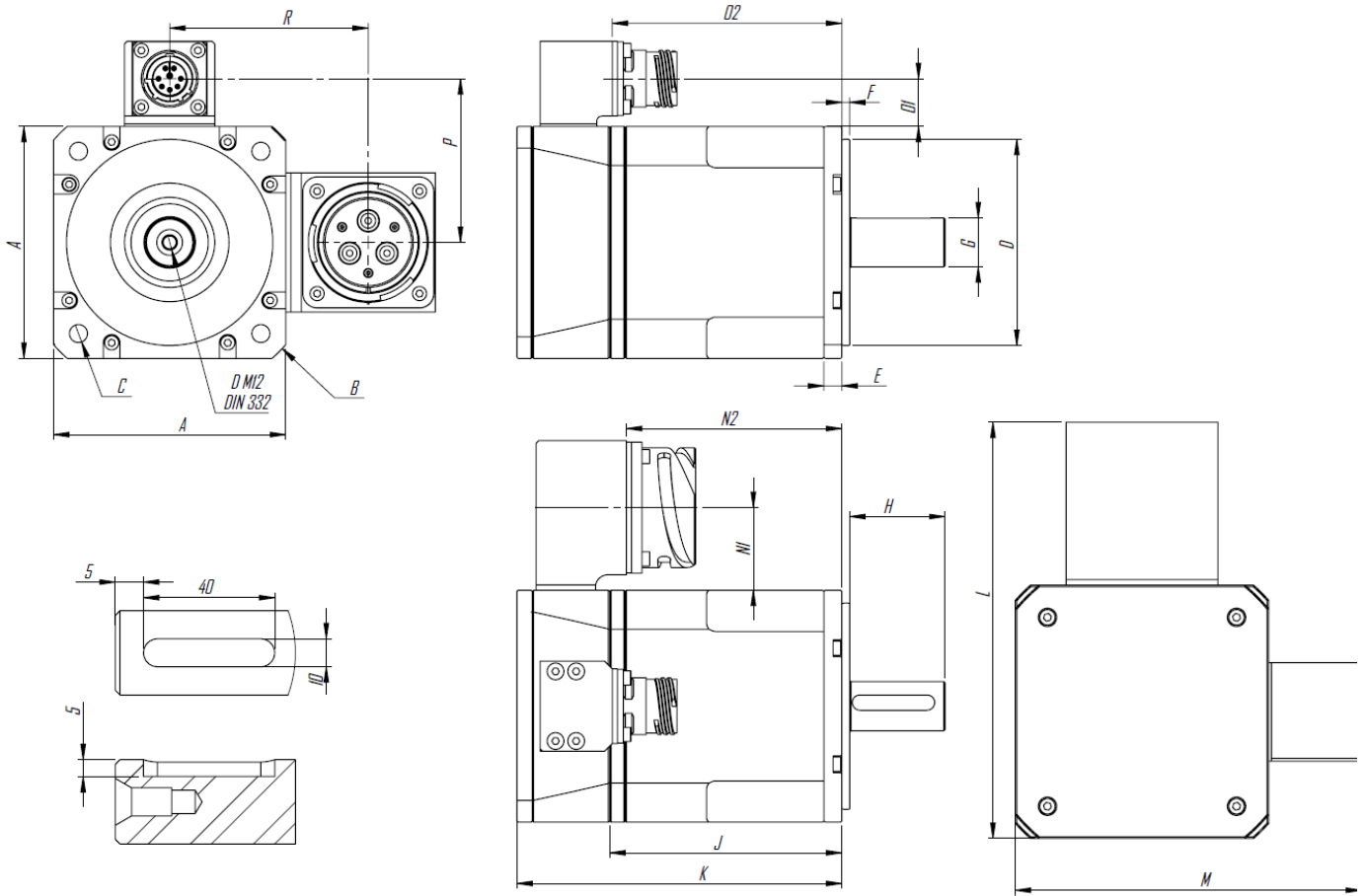

Symbols	Units	Frensiz			Frenli		
		LVSM-130-01	LVSM-130-02	LVSM-130-03	LVSM-130-01	LVSM-130-02	LVSM-130-03
A	mm	130	130	130	130	130	130
B	mm	176	176	176	176	176	176
C	mm	Ø9 on Ø145	Ø9 on Ø145	Ø9 on Ø145	Ø9 on Ø145	Ø9 on Ø145	Ø9 on Ø145
D	mm	Ø110	Ø110	Ø110	Ø110	Ø110	Ø110
E	mm	12	12	12	12	12	12
F	mm	3.5	3.5	3.5	3.5	3.5	3.5
G	mm	Ø32	Ø32	Ø32	Ø32	Ø32	Ø32
J	mm	101	141	181	101	141	181
K	mm	149	189	229	204	244	284
L	mm	201	201	201	201	201	201
M	mm	163	163	163	163	163	163
N1	mm	38	38	38	38	38	38
N2	mm	98	138	178	158	198	238
O1	mm	19	19	19	19	19	19
O2	mm	103	143	183	153	193	233
P	mm	84	84	84	84	84	84
R	mm	103	103	103	103	103	103

# Power - Signal Connector

Power Connector (CB2-36-3-PC-FM)

Pin	Function	Description
A	GND	GND
B	B	Phase B
C	-	-
D	C	Phase C
E	-	-
F	A	Phase A

Signal Connector (D38999/20WC8PN)

Pin	Function	Description
A	R1	Ref (+)
B	R2	Ref (-)
C	S1	Cos (+)
D	S3	Cos (-)
E	S2	Sin (+)
F	S4	Sin (-)
G	NTC	Thermal Sensor
H	NTC	Thermal Sensor