

LVSM-100 Technical Information

Motor Parameters			LVSM-100-01				LVSM-100-02				LVSM-100-03				
Winding Type	Symbols	Units	A		B		A		B		A		B		
PERFORMANCE	DC Bus Voltage	V _{dc}	24	48	24	48	24	48	24	48	24	48	24	48	
	Rated Power	P _r	0.54	1.12	0.73	1.45	0.95	1.88	1.36	2.54	1.45	2.76	1.76	3.14	
	Stall Torque	T _s	2.72	2.72	2.79	2.79	5.10	5.10	4.99	4.99	6.80	6.80	6.76	6.76	
	Rated Torque	T _r	2.63	2.55	2.67	2.52	4.89	4.59	4.76	4.26	6.51	5.92	6.45	5.56	
	Peak Torque	T _p	7.96	7.96	7.97	7.97	15.9	15.9	15.9	15.9	23.9	23.9	23.9	23.9	
	Rated Speed	N _r	rpm	1950	4200	2600	5500	1850	3900	2725	5700	2125	4450	2600	5400
	No-Load Speed ⁽²⁾	N _{no-load}	rpm	2589	5178	3329	6657	2330	4660	3329	6657	2589	5178	3105	6210
	Torque Constant	K _t	Nm/ A _{rms}	0.11	0.11	0.08	0.08	0.12	0.12	0.08	0.08	0.11	0.11	0.09	0.09
	Voltage Constant ⁽²⁾	K _v	V _{rms} /krpm	6.55	6.55	5.10	5.10	7.28	7.28	5.10	5.10	6.55	6.55	5.47	5.47
	ELECTRICAL	Stall Current	I _s	25.2	25.2	33.1	33.1	42.4	42.4	59.2	59.2	62.6	62.6	74.7	74.7
Rated Current		I _r	24.7	24.0	32.2	30.7	41.1	38.9	57.5	51.9	60.8	55.7	72.5	63.3	
Peak Current		I _p	75.9	75.9	97.7	97.7	137	137	195	195	228	228	273	273	
Line Resistance ⁽²⁾		R _{LL}	mOhm	56.0 (±20%)	55.6 (±20%)	33.2 (±20%)	33.2 (±20%)	27.2 (±20%)	27.2 (±20%)	12.4 (±20%)	12.4 (±20%)	12.6 (±20%)	12.6 (±20%)	8.80 (±20%)	8.80 (±20%)
Line Inductance ⁽²⁾		L _{LL}	mH	0.20 (±30%)	0.20 (±30%)	0.12 (±30%)	0.12 (±30%)	0.12 (±30%)	0.12 (±30%)	0.06 (±30%)	0.06 (±30%)	0.06 (±30%)	0.06 (±30%)	0.04 (±30%)	0.04 (±30%)
Inertia (without brake)		J	kg.cm ²	2.15	2.15	2.15	2.15	3.9	3.9	3.9	3.9	5.65	5.65	5.65	5.65
Weight (without brake)		W	kg	3.81	3.79	3.79	3.79	5.43	5.43	5.42	5.42	7.06	7.06	7.08	7.08
Thermal Resistance ⁽²⁾		K _{therm}	C°/W	1.60	1.31	1.49	1.10	1.15	0.92	1.11	0.78	1.04	0.78	0.94	0.64
Mech. Time Constant		K _{mech}	ms	1.26	1.24	1.23	1.23	0.90	0.89	0.83	0.83	0.74	0.74	0.74	0.74
Motor Constant		K _m	Nm/VW	0.38	0.39	0.39	0.41	0.61	0.65	0.64	0.70	0.81	0.89	0.81	0.93
FEEDBACK	Pole Number	n	10												
	Input Voltage	V _{rms}	5												
	Frequency	kHz	4.5												
	Input Current	mA	58												
	Transformation Ratio		0.5±10%												
	Null Voltage	mV _{max}	30												
	Phase Shift	Deg	-15°±2°												

1. All performance and electrical specifications are obtained at 25°C ambient and may change ±10%. 2. Rated data with reference aluminum plate 300mm x 300mm x 12mm (maximum winding temperature is 120°C). 3. Higher torque and speed values as well as dimensions on request.

LVSM-100 Torque-Speed Curves

Tr: Rated Torque — @Tr 24V - - - @Tr 48V
 Tp: Peak Torque — @Tp 24V - - - @Tp 48V

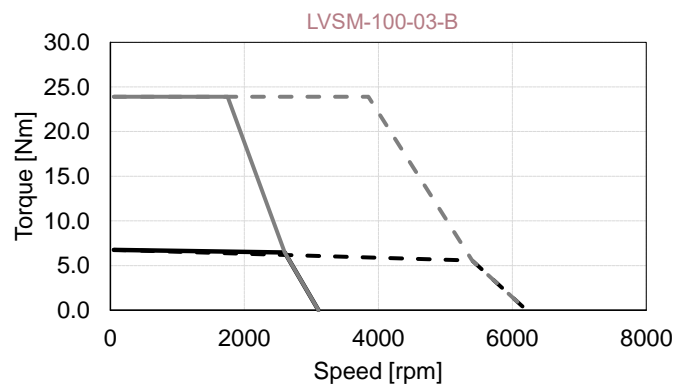
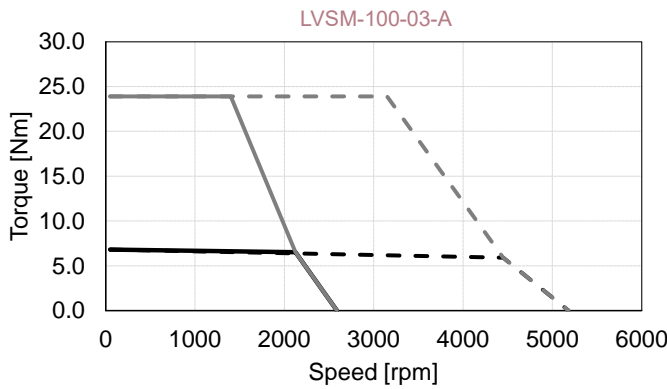
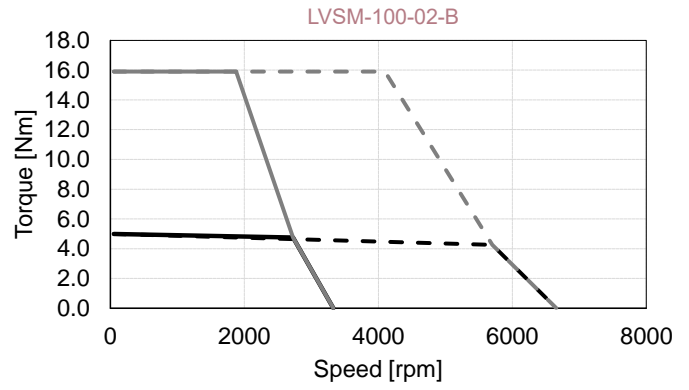
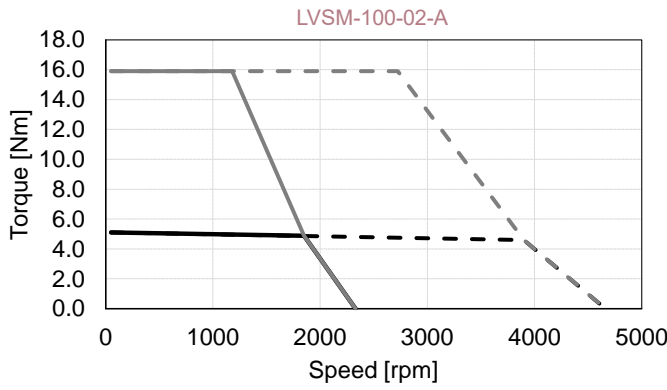
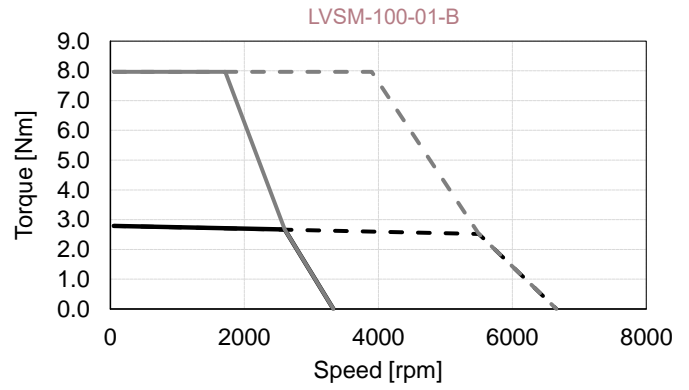
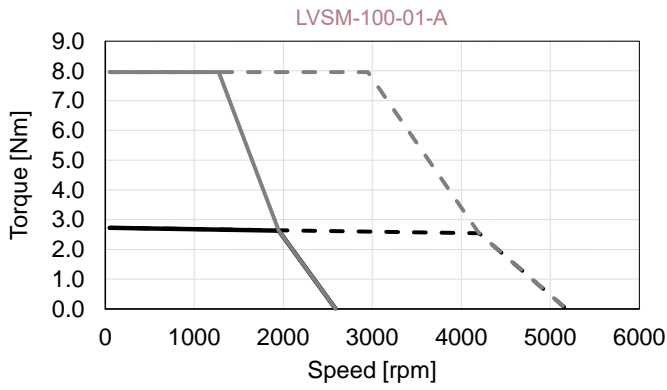

LVSM-100 Outline Drawing

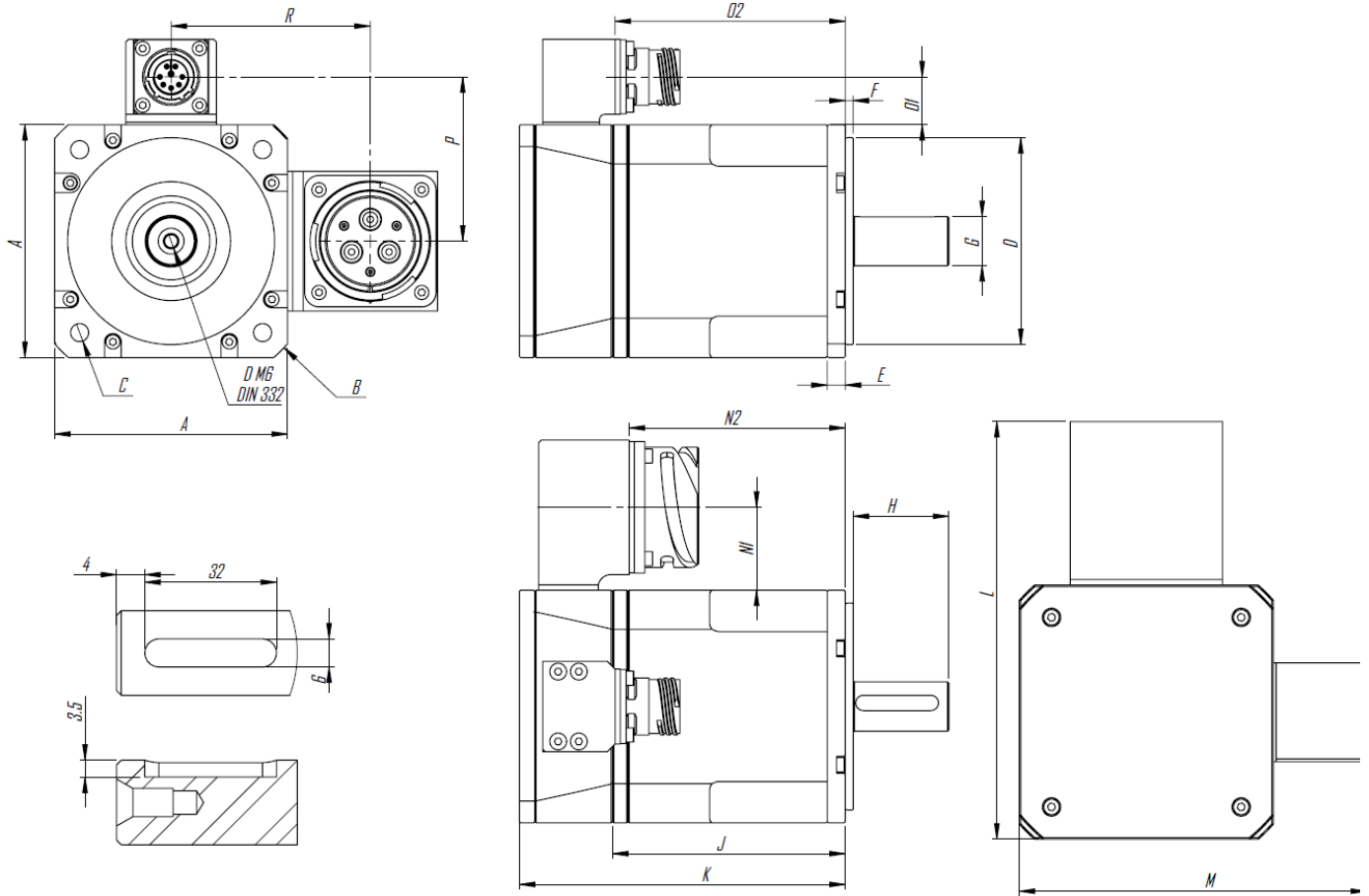

Symbols	Units	Frensiz			Frenli		
		LVSM-100-01	LVSM-100-02	LVSM-100-03	LVSM-100-01	LVSM-100-02	LVSM-100-03
A	mm	100	100	100	100	100	100
B	mm	Ø134	Ø134	Ø134	Ø134	Ø134	Ø134
C	mm	Ø9 on Ø115	Ø9 on Ø115	Ø9 on Ø115	Ø9 on Ø115	Ø9 on Ø115	Ø9 on Ø115
D	mm	Ø95	Ø95	Ø95	Ø95	Ø95	Ø95
E	mm	10	10	10	10	10	10
F	mm	3	3	3	3	3	3
G	mm	Ø24	Ø24	Ø24	Ø24	Ø24	Ø24
J	mm	82	112	142	82	112	142
K	mm	114	144	174	156	186	216
L	mm	157	157	157	157	157	157
M	mm	133	133	133	133	133	133
N1	mm	31	31	31	31	31	31
N2	mm	72	102	132	114	144	174
O1	mm	19	19	19	19	19	19
O2	mm	75	105	135	117	147	177
P	mm	69	69	69	69	69	69
R	mm	81	81	81	81	81	81

Power - Signal Connector

Power Connector (CB2-28-22-PC-FM)

Pin	Function	Description
A	A	Phase A
B	B	Phase B
C	C	Phase C
D	-	-
E	-	-
F	GND	GND

Signal Connector (D38999/20WC8PN)

Pin	Function	Description
A	R1	Ref (+)
B	R2	Ref (-)
C	S1	Cos (+)
D	S3	Cos (-)
E	S2	Sin (+)
F	S4	Sin (-)
G	NTC	Thermal Sensor
H	NTC	Thermal Sensor