

# LVSM-090 Technical Information

Motor Parameters			LVSM-090-01				LVSM-090-02				LVSM-090-03				
Winding Type	Symbols	Units	A		B		A		B		A		B		
PERFORMANCE	DC Bus Voltage	V <sub>dc</sub>	V	24	48	24	48	24	48	24	48	24	48	24	48
	Rated Power	P <sub>r</sub>	W	0.73	1.40	1.09	1.81	0.97	1.86	1.30	2.24	1.38	2.54	1.74	2.71
	Stall Torque	T <sub>s</sub>	Nm	3.00	3.00	2.92	2.92	5.35	5.35	5.19	5.19	7.05	7.05	6.91	6.91
	Rated Torque	T <sub>r</sub>	Nm	2.83	2.56	2.72	2.13	5.02	4.49	4.86	3.96	6.59	5.64	6.46	4.75
	Peak Torque	T <sub>p</sub>	Nm	8.64	8.64	8.64	8.64	17.3	17.3	17.3	17.3	25.9	25.9	25.9	25.9
	Rated Speed	N <sub>r</sub>	rpm	2450	5225	3825	8100	1850	3950	2550	5400	2000	4300	2575	5450
	No-Load Speed <sup>(2)</sup>	N <sub>no-load</sub>	rpm	3109	6218	4660	9320	2330	4660	3109	6218	2487	4974	3109	6218
	Torque Constant	K <sub>t</sub>	Nm/ A <sub>rms</sub>	0.09	0.09	0.06	0.06	0.12	0.12	0.09	0.09	0.11	0.11	0.09	0.09
	Voltage Constant <sup>(2)</sup>	K <sub>v</sub>	V <sub>rms</sub> /krpm	5.46	5.46	3.64	3.64	7.28	7.28	5.46	5.46	6.82	6.82	5.46	5.46
ELECTRICAL	Stall Current	I <sub>s</sub>	A <sub>rms</sub>	33.3	33.3	48.5	48.5	44.5	44.5	57.6	57.6	62.5	62.5	76.6	76.6
	Rated Current	I <sub>r</sub>	A <sub>rms</sub>	32.0	29.2	46.2	37.0	42.4	38.2	54.9	45.3	59.5	51.4	73.0	54.6
	Peak Current	I <sub>p</sub>	A <sub>rms</sub>	101	101	152	152	152	152	202	202	242	242	303	303
	Line Resistance <sup>(2)</sup>	R <sub>LL</sub>	mOhm	32 (±20%)	32 (±20%)	14 (±20%)	14 (±20%)	23 (±20%)	23 (±20%)	13 (±20%)	13 (±20%)	13 (±20%)	13 (±20%)	8 (±20%)	8 (±20%)
	Line Inductance <sup>(2)</sup>	L <sub>LL</sub>	mH	0.18 (±30%)	0.18 (±30%)	0.12 (±30%)	0.12 (±30%)	0.17 (±30%)	0.17 (±30%)	0.09 (±30%)	0.09 (±30%)	0.13 (±30%)	0.13 (±30%)	0.08 (±30%)	0.08 (±30%)
	Inertia (without brake)	J	kg.cm <sup>2</sup>	2.0	2.0	2.0	2.0	3.7	3.7	3.7	3.7	5.4	5.4	5.4	5.4
	Weight (without brake)	W	kg	3.59	3.61	3.61	3.61	5.30	5.30	5.30	5.30	6.97	6.97	6.99	6.99
	Thermal Resistance <sup>(2)</sup>	K <sub>therm</sub>	C°/W	1.80	1.37	1.59	1.00	1.42	1.13	1.32	0.94	1.18	0.87	1.09	0.75
	Mech. Time Constant	K <sub>mech</sub>	ms	0.96	0.96	0.96	0.96	0.72	0.72	0.72	0.72	0.67	0.66	0.66	0.66
	Motor Constant	K <sub>m</sub>	Nm/vW	0.43	0.47	0.43	0.54	0.68	0.75	0.68	0.82	0.85	0.99	0.86	1.15
FEEDBACK	Pole Number	n	10												
	Input Voltage	V <sub>rms</sub>	5												
	Frequency	kHz	4.5												
	Input Current	mA	58												
	Transformation Ratio		0.5±10%												
	Null Voltage	mV <sub>max</sub>	30												
	Phase Shift	Deg	-15°±2°												

1. All performance and electrical specifications are obtained at 25°C ambient and may change ±10%. 2. Rated data with reference aluminum plate 250mm x 250mm x 6mm (maximum winding temperature is 120°C). 3. Higher torque and speed values as well as dimensions on request.

# LVSM-090 Torque-Speed Curves

Tr: Rated Torque @Tr 24V --- @Tr 48V  
 Tp: Peak Torque @Tp 24V - - - @Tp 48V

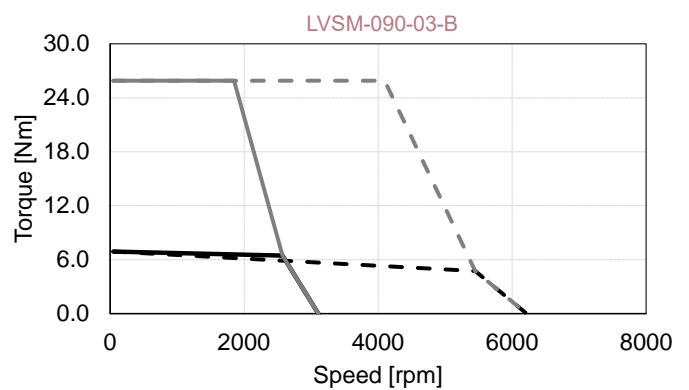
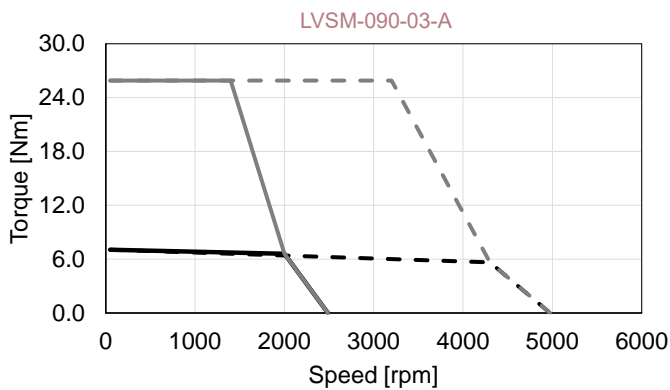
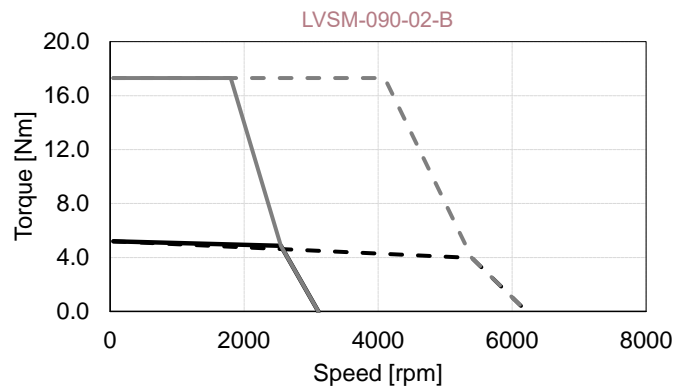
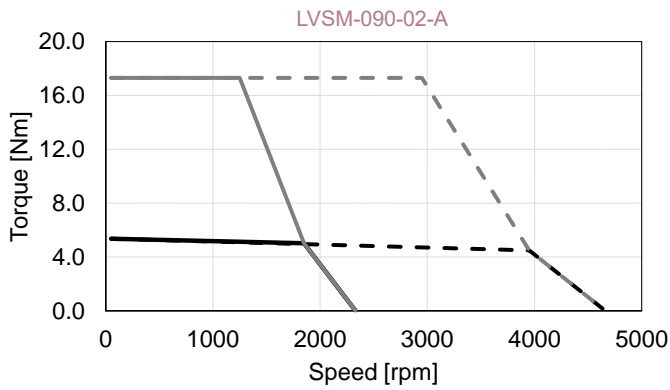
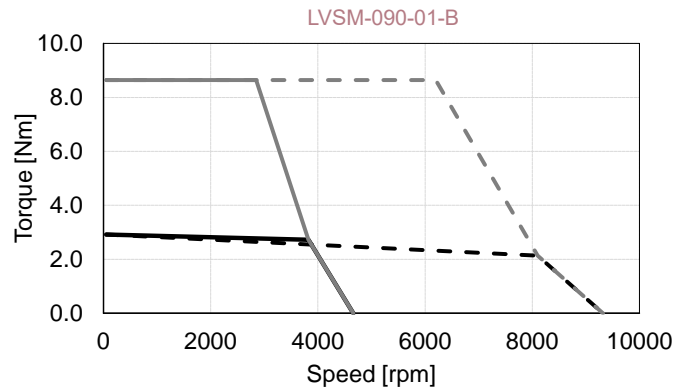
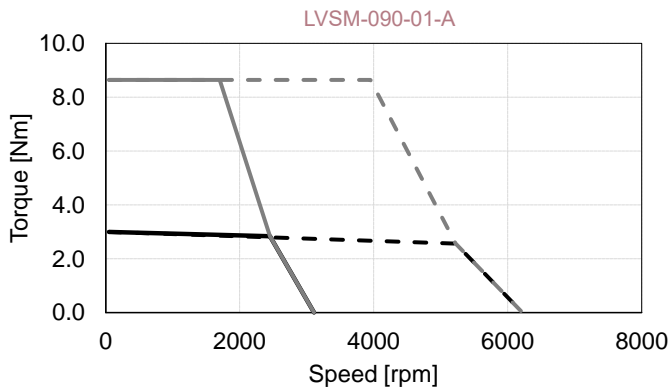

# LVSM-090 Outline Drawing

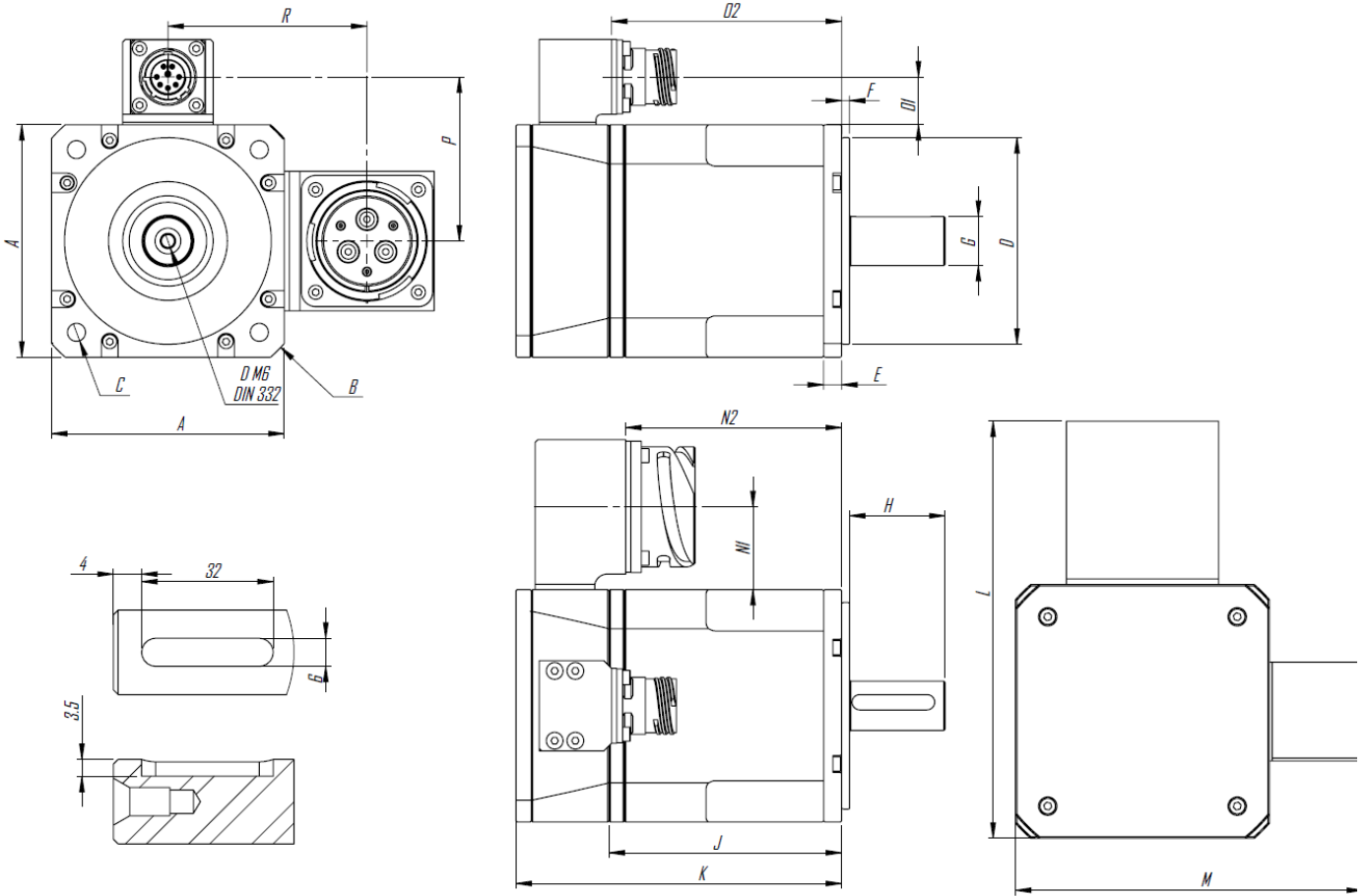

Symbols	Units	Frensiz			Frenli		
		LVSM-090-01	LVSM-090-02	LVSM-090-03	LVSM-090-01	LVSM-090-02	LVSM-090-03
A	mm	90	90	90	90	90	90
B	mm	Ø120	Ø120	Ø120	Ø120	Ø120	Ø120
C	mm	Ø 7 on Ø100	Ø 7 on Ø100	Ø 7 on Ø100	Ø 7 on Ø100	Ø 7 on Ø100	Ø 7 on Ø100
D	mm	Ø80	Ø80	Ø80	Ø80	Ø80	Ø80
E	mm	7	7	7	7	7	7
F	mm	3	3	3	3	3	3
G	mm	Ø 19	Ø 19	Ø 19	Ø 19	Ø 19	Ø 19
J	mm	90	130	170	90	130	170
K	mm	161	201	241	161	201	241
L	mm	123	123	123	123	123	123
M	mm	148	148	148	148	148	148
N1	mm	32	32	32	32	32	32
N2	mm	84	129	169	119	159	199
O1	mm	19	19	19	19	19	19
O2	mm	89	124	164	124	164	204
P	mm	64	64	64	64	64	64
R	mm	77	77	77	77	77	77

# Power - Signal Connector

Power Connector (CB2-28-22-PC-FM)

Pin	Function	Description
A	A	Phase A
B	B	Phase B
C	C	Phase C
D	-	-
E	-	-
F	GND	GND

Signal Connector (D38999/20WC8PN)

Pin	Function	Description
A	R1	Ref (+)
B	R2	Ref (-)
C	S1	Cos (+)
D	S3	Cos (-)
E	S2	Sin (+)
F	S4	Sin (-)
G	NTC	Thermal Sensor
H	NTC	Thermal Sensor