

TRM Catalog

TRM Series Frameless Torque Motors

130-390 OD Frame Size

www.mdsmotor.com

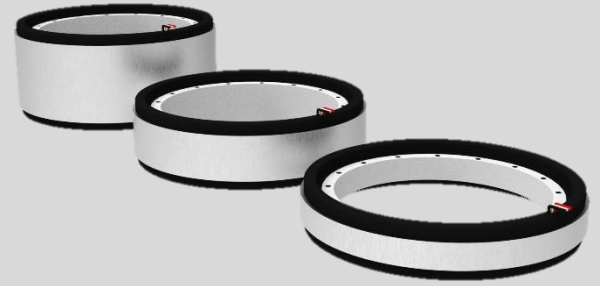

MDS Motor
Feel the perfect motion...

Kocaeli Üniversitesi Teknopark |
Vatan Cad. No:83 |41275 |
Başiskele, Kocaeli, Türkiye

Table of Content

TRM Series Frameless Torque Motors.....	1
Overview of TRM Series Frameless Torque Motors Range.....	2
TRM Series Motors – Torque Range.....	3
Performance Benefits of TRM Series Frameless Torque Motors.....	4
Motor Description.....	5
Motor Size Range.....	6
Torque Motor Selection.....	7
Definition of Torque–Speed Curves and Field Weakening.....	8
Available Modifications for MDS Torque Motors.....	9
Axial Forces During Assembly.....	10
Notes.....	11
Definition of Motor Parameters.....	12
TRM-130 Datasheet.....	13
TRM-150 Datasheet.....	16
TRM-160 Datasheet.....	19
TRM-175 Datasheet.....	22
TRM-200 Datasheet.....	25
TRM-230 Datasheet.....	28
TRM-240 Datasheet.....	31
TRM-260 Datasheet.....	34
TRM-290 Datasheet.....	37
TRM-310 Datasheet.....	40
TRM-330 Datasheet.....	43
TRM-360 Datasheet.....	46
TRM-372 Datasheet.....	49
TRM-390 Datasheet.....	52
Hall Effect Sensor Information.....	55
Motor Design Sheet.....	56
Notes.....	57

TRM Series Frameless Torque Motors

MDS has several new frameless motor series for direct drive applications.

MDS torque motor series are engineered to deliver the high-performance, high efficiency direct drive torque motors that today's applications demand. There exist 3 main torque motor series offered: Frameless and framed torque motor with and without liquid cooling. Optional digital Hall effect sensors are pre-aligned and installed with added axial rotor length to achieve accurate control. Choice of insulation allows operation from 24V up to 560V peak line input voltage. Detailed motor datasheets and variety of motor options and configurations provide the best selection for your needs.

For customized motor selections or new custom motor specifications, contact MDS Motor to help us understand exactly what you need and how we can further optimize any MDS torque motor series. MDS Motor is expert in providing optimized custom solutions for your applications with utilizing different materials, special winding structures, tailored mounting features, height and diameter adjustments and etc.

TRM series frameless torque motor product family includes two different sub series according to DC bus voltage levels. **Low voltage (24/48V) motors are named as TML series torque motor. High voltage (310/560V) motors are named as TMH series torque motor.**

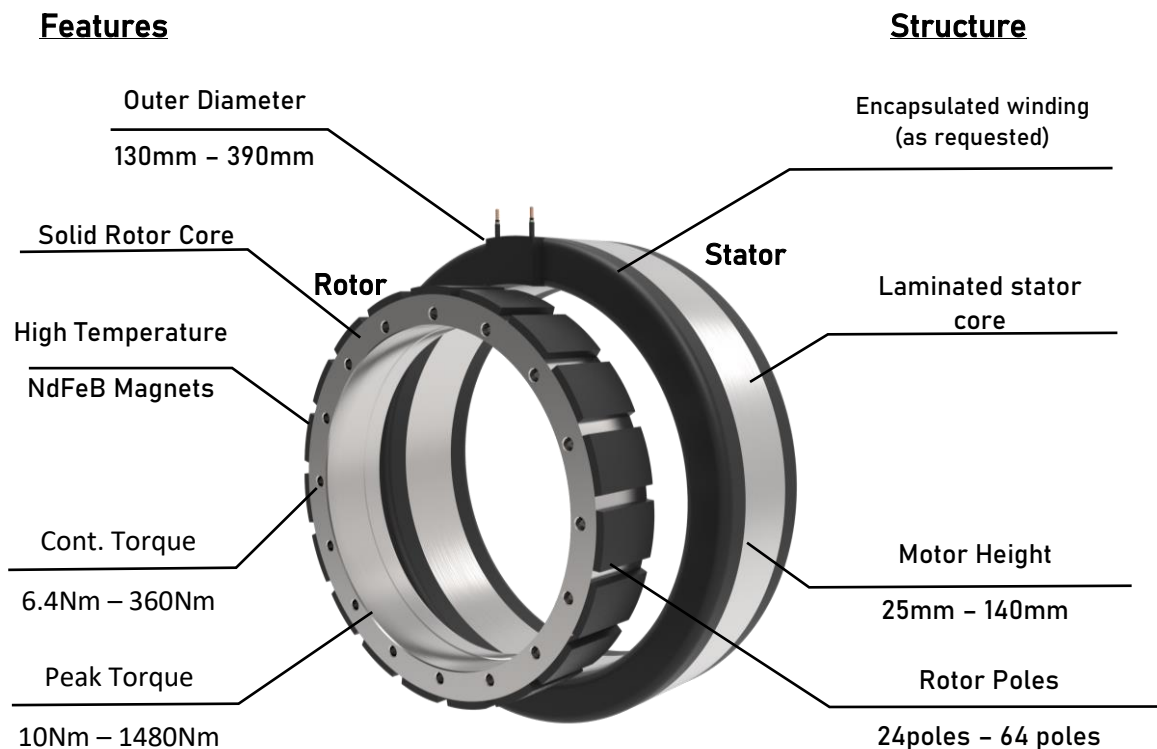

Overview of TRM Series Frameless Torque Motors Range

- Low Rated Speed for Direct Drive
- Very Low Cogging Torque and Torque Ripple
- Very Low Total Harmonic Distortion THD
- Low Stator and Rotor Active Mass
- Large Outer/Inner Diameter up to 390mm
- Low Thermal Resistance
- Shielded Cable option
- Good Product Quality
- 100% Quality Inspection



TRM-130



TRM-150



TRM-160



TRM-175



TRM-200



TRM-230



TRM-240



TRM-260



TRM-290



TRM-310



TRM-330



TRM-360



TRM-372



TRM-390

TRM Series Motors – Torque Range

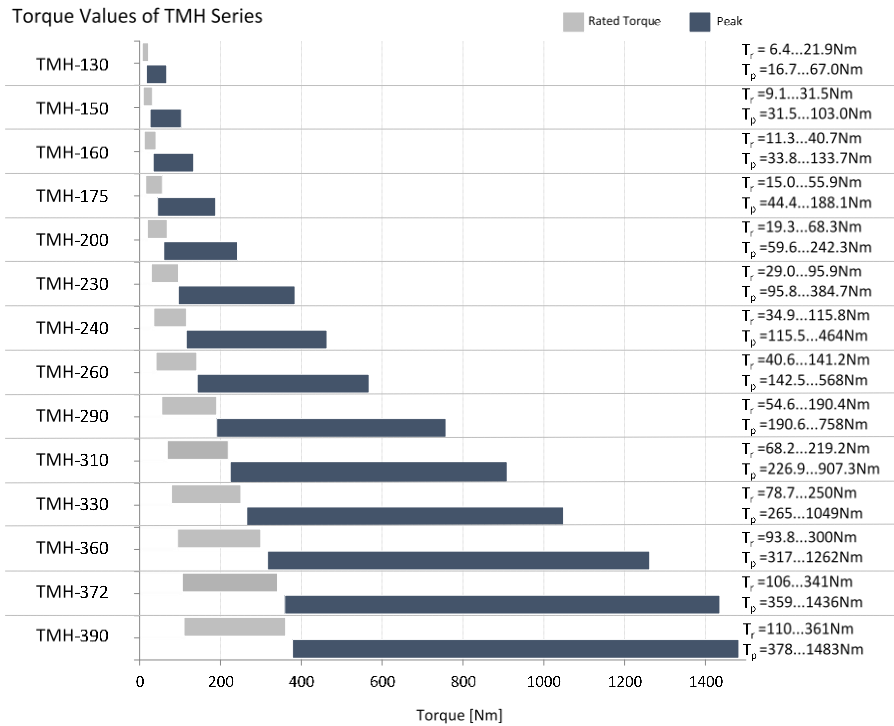
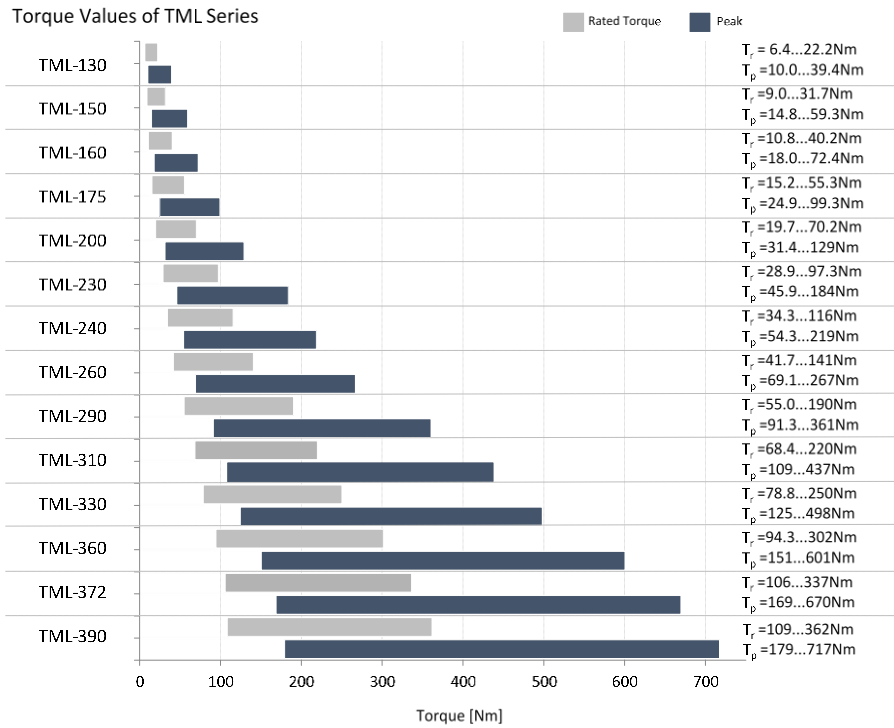

Performance Benefits of TRM Series Frameless Torque Motors

- **Perfect Frameless Torque Motor Performance**
 - Perfect electromagnetic designs delivered to provide maximum torque density
 - Maximum torque-per-weight ratios
 - Small volume and active weight
 - Extremely small cogging torque (usually less than 0.2% of rated torque)
 - Extremely small torque ripple to have smooth rotation (usually less than 0.4%)
 - Extremely low Back-EMF total harmonic distortion (THD) (usually less than 0.3%)
 - Wide operating speed range with AC winding options and rapid acceleration
 - Lowest possible rotor inertia (can be increased if requested)
- **Quality Manufacturing Guarantees Reliability**
 - Rotor covered with non-magnetic sleeve for high-speed models
 - 130°C maximum winding temperature rating with integrated thermistor
 - Manufactured with UL recommended insulation systems
 - RoHS compliant magnet and magnetic core material selection
- **Variety of Dimensions and Stacks with Configurable Features**
 - 14 frame sizes with multiple stack lengths
 - Standard high and low voltage insulation
 - Hall effect sensor options
 - Multiple AC windings with custom windings options
 - Easily accommodated interface with bolt holes in the rotor and keyway on the stator

Motor Description

MDS TRM series frameless torque motors are low speed synchronous permanent magnet motors and do not include bearings or an encoder/resolver. Each torque motor has the rotor and the stator with an option of hall effect sensors.

MDS's torque motors are inner rotor type family. The stator is made of high-quality laminated steel and includes 3 phase AC windings. The windings are filled with epoxy potting to improve motor the thermal behavior and winding insulation. Phase interconnections are made inside the winding and leads are brought out with 500mm shielded cables. Both low voltage and high voltage winding options are presented to the customers with natural cooling.

The rotating inner rotor has a steel ring with corrosion protected sintered Nd-Fe-B permanent magnets on the surface covered with a thin layer of sleeve.

MDS's torque motors provide high torque constants, small size and low thermal resistance. All torque motors are electrically shielded to comply with EMC standards.

All MDS's synchronous torque motors are delivered with a special holding structure having rotor and the stator together.

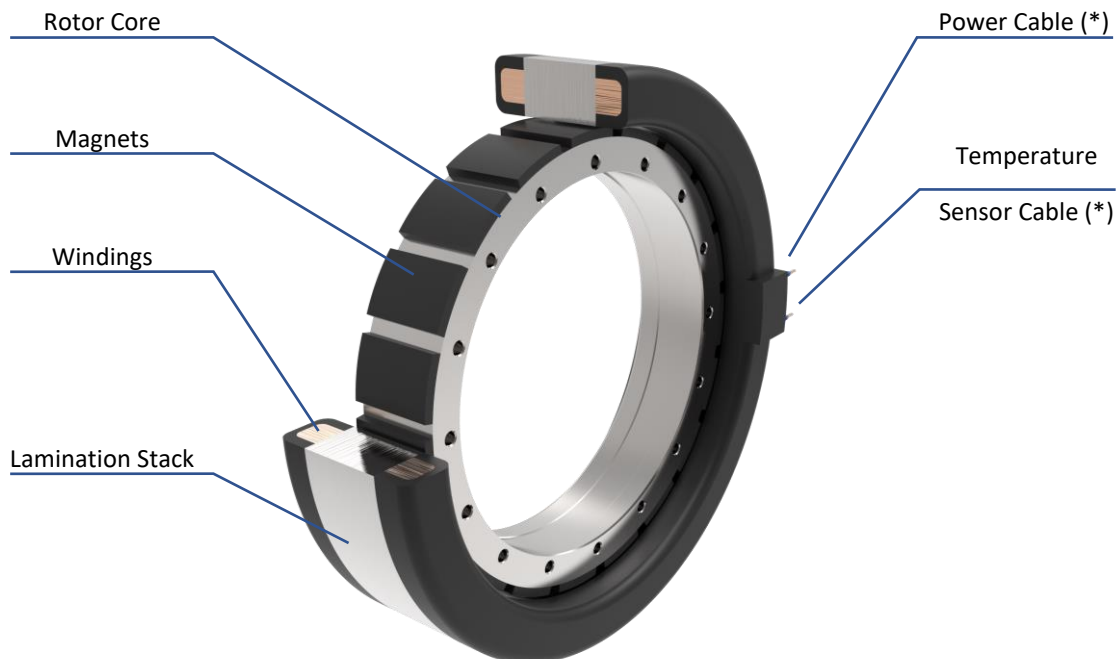

(*): Unless specially requested, MDS's synchronous torque motors are delivered with a 500mm shielded cable without connectors.

Motor Size Range

The TRM series torque motor family is made up of 14 different motor diameters with 3 possible stacks and 2 possible voltage options.

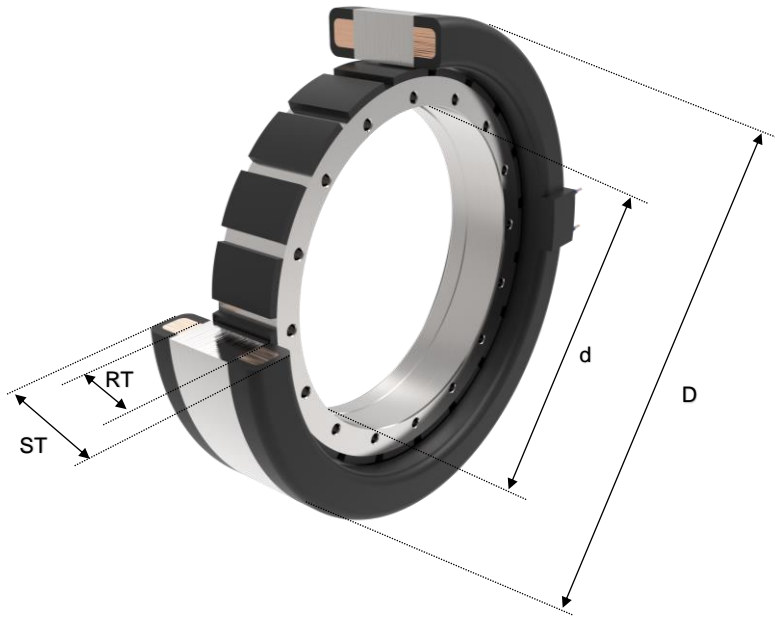

Motor series	External diameter D (mm)	Internal diameter d (mm)	Stator length ST (mm)	Rotor length RT (mm)
TM(L/H)130-25	130	55	55	25.1
TM(L/H)130-50	130	55	80	50.2
TM(L/H)130-100	130	55	130	100.4
TM(L/H)150-25	150	70	55	25.1
TM(L/H)150-50	150	70	80	50.2
TM(L/H)150-100	150	70	130	100.4
TM(L/H)160-25	160	80	57	25.1
TM(L/H)160-50	160	80	82	50.2
TM(L/H)160-100	160	80	132	100.4
TM(L/H)175-30	175	88	62	30.1
TM(L/H)175-60	175	88	92	60.2
TM(L/H)175-120	175	88	152	120.4
TM(L/H)200-30	200	120	62	30.1
TM(L/H)200-60	200	120	92	60.2
TM(L/H)200-120	200	120	152	120.4
TM(L/H)230-30	230	148	62	30.1
TM(L/H)230-60	230	148	92	60.2
TM(L/H)230-120	230	148	152	120.4
TM(L/H)240-35	240	158	69	35.1
TM(L/H)240-70	240	158	104	70.2
TM(L/H)240-140	240	158	174	140.4

Motor series	External diameter D (mm)	Internal diameter d (mm)	Stator length ST (mm)	Rotor length RT (mm)
TM(L/H)260-35	260	178	69	35.1
TM(L/H)260-70	260	178	104	70.2
TM(L/H)260-140	260	178	174	140.4
TM(L/H)290-35	290	200	69	35.1
TM(L/H)290-70	290	200	104	70.2
TM(L/H)290-140	290	200	174	140.4
TM(L/H)310-35	310	220	69	35.1
TM(L/H)310-70	310	220	104	70.2
TM(L/H)310-140	310	220	174	140.4
TM(L/H)330-35	330	240	69	35.1
TM(L/H)330-70	330	240	104	70.2
TM(L/H)330-140	330	240	174	140.4
TM(L/H)360-35	360	270	69	35.1
TM(L/H)360-70	360	270	104	70.2
TM(L/H)360-140	360	270	174	140.4
TM(L/H)372-35	372	287	69	35.1
TM(L/H)372-70	372	287	104	70.2
TM(L/H)372-140	372	287	174	140.4
TM(L/H)390-35	390	290	69	35.1
TM(L/H)390-70	390	290	104	70.2
TM(L/H)390-140	390	290	174	140.4

Torque Motor Selection

This section defines how to select a MDS's frameless torque motors for user's requirements. The technique described here applies to MDS's whole series of torque motors. The selection of torque motors depends on the user defined applications. These motors can simply be selected by matching the technical specifications of the application. In some cases, a field test may be necessary to optimize or qualify the selected torque motor. Please contact MDS Motor if you need a custom-made motor.

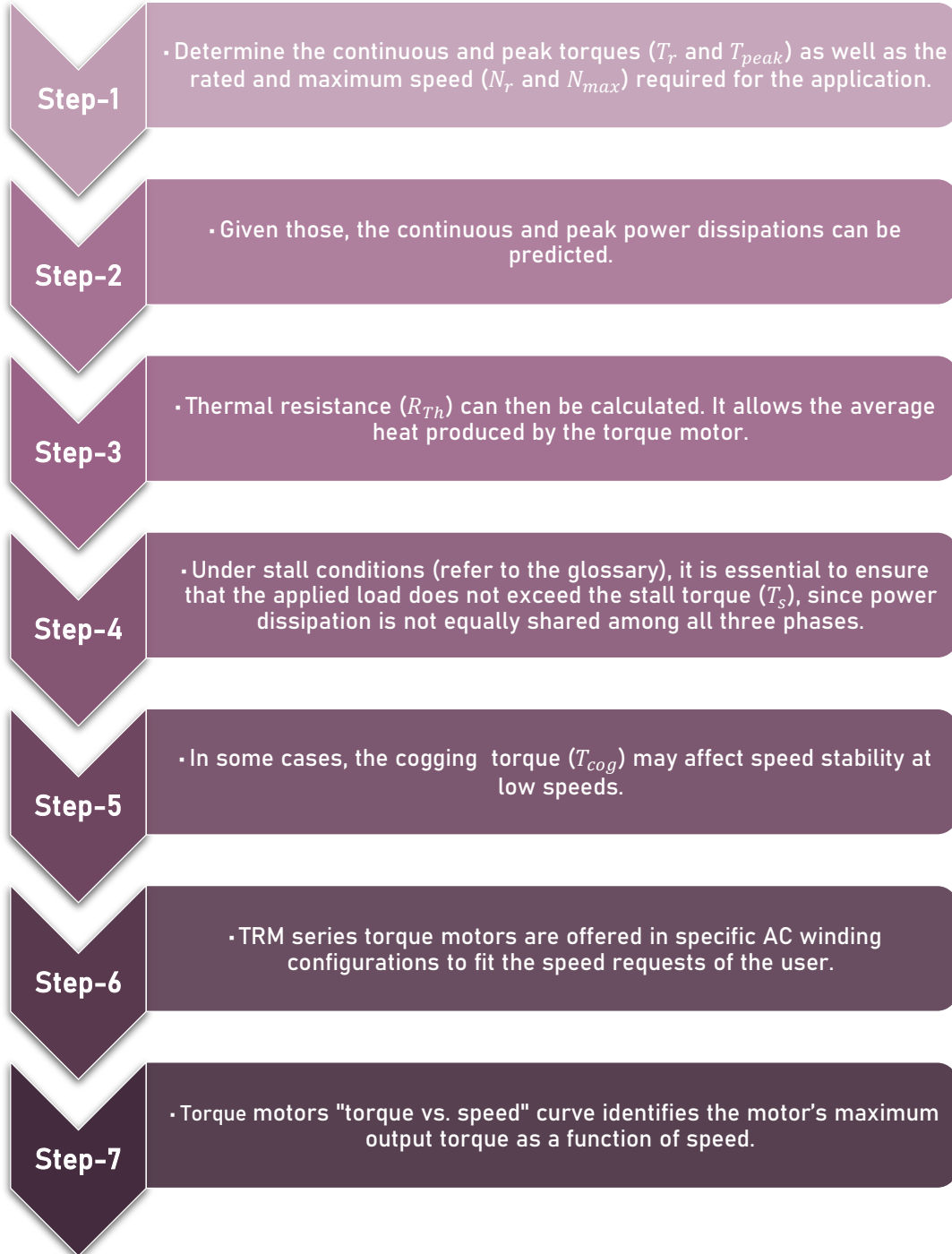

Definition of Torque–Speed Curves and Field Weakening

Data sheets of TRM series torque motors include the following torque - speed profiles. The torque-speed curves depend on following critical parameters:

- DC bus voltage
- Motor resistance
- Motor inductance
- Motor torque and voltage constants
- Power dissipation

Torque - speed curves are usually obtained using DC bus voltage, continuous/peak AC current, phase resistance and temperature.

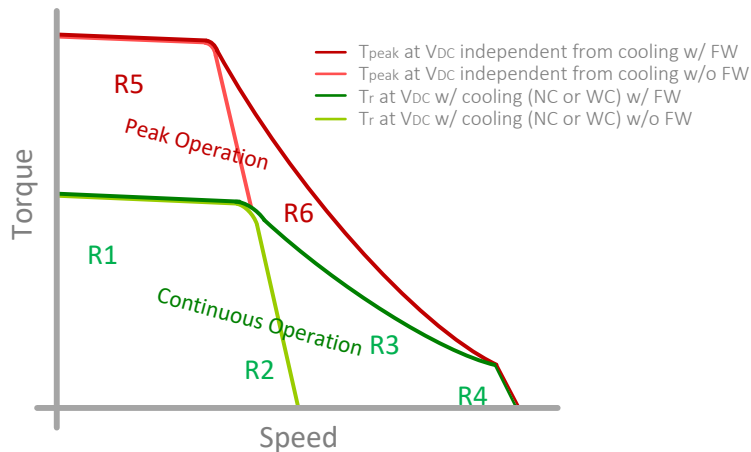

The continuous operation has four regions (bordered by green line):

- Region 1: Constant torque region with $I_q=I_r$, $I_d=0$ (bounded by thermal protection of stator)
- Region 2: Constant power region with $I_q=I_r$, $I_d=0$
- Region 3: Constant power region with $I_q \neq I_r$, $I_d < I_r$ (protection against the demagnetization of the magnets)
- Region 4: Limits defined by the DC bus voltage and mechanical limits

The discontinuous or peak operation has two regions (bordered by red line):

- Region 5: Peak torque region with $I_q=I_{peak}$, $I_d=0$ (bounded by thermal protection of stator)
- Region 6: Peak torque region with $I_q=I_{peak}$, $I_d < I_r$ (bounded by thermal protection of stator)

Field weakening is used in torque motors to extend the operating speed. At low speeds up to rated speed (during constant torque region), field weakening control is not active and thus torque, or torque constant, is kept constant. Field-weakening control is activated beyond the rated motor speed. Torque is decreased so as to achieve higher speeds with almost constant power. Furthermore, water cooling may be compulsory for some torque motors to operate at field-weakening mode.

Both rated speed and maximum speed limits are defined in each MDS torque motor datasheet. The rated speed is the value at which the DC bus voltage reaches the limit. This is also the end of constant torque region. The power can be kept the same up to a speed where the constant power ends. The maximum speed is based on a safety criterion in case of an emergency during field-weakening. During high-speed operation, the Back-EMF voltage can reach up to a few thousand volts. The customer's motor drive has to be selected (or designed) based on this mode. Motor operation beyond maximum

speed specified on datasheet can lead to serious damages in your system and can not be recommended.

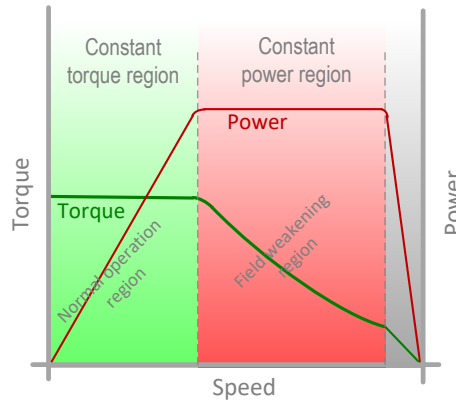

Available Modifications for MDS Torque Motors

Depending on the application needs of the customers, MDS engineers are capable of design modifications of our optimized base model frameless torque-motors. Please consult MDS Motor for detailed information, pricing, and feasibility of the desired modifications you need. Please consider that extended lead time and additional design fees are required.

Changes on Torque / Speed Curves

- Stack Outer Diameter
- Stack Lengths
- Number of Poles
- Magnet Material

Available MDS's Capability

- 130 mm to 390 mm
- 12.5 mm to 210 mm
- 16 to 64 poles
- NdFeB (base models) and SmCo

Installation Features

- Mounting
Diameter of bolt holes on rotor core, pattern and keyway dimensions
- Lead Colors
Red / White / Black (base models)
- Lead Length
500 mm (base models) 100 mm to 1500 mm
- Sensor
Hall effect sensor options
- Thermal sensor
Thermistor (base models)
RTD, Thermocouples
- Connectors
None is used (base models)
Customer specified connectors

Axial Forces During Assembly

When the rotor is inserted inside the stator, an axial force occurs between the rotor and stator because of the axial asymmetry of the permanent magnet (PM) with respect to the stator, uneven magnetization of the PM and the eccentricity of the rotor and stator. This force are the dominant sources of magnetically induced vibration and noise in motors. Therefore, during assembly of rotor and stator, this effect must be considered by user.

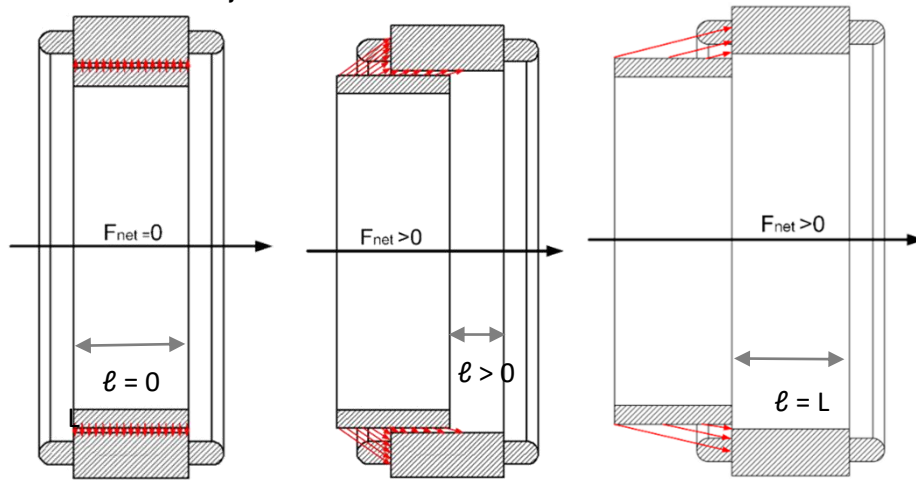

Axial Forces without Axis Eccentricity

Axial Forces with Axis Eccentricity

Axial Forces with Large Axis Eccentricity

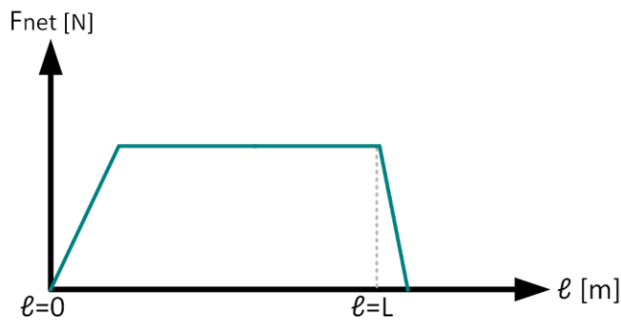

This force does not depend on the axial position of the rotor in the stator.

Definition of Motor Parameters

Rated Torque	T_r	Torque value at rated speed when continuous power is the output
Peak Torque	T_p	Maximum torque that the motor delivers when maximum current (I_p) is provided. Peak torque is available for a maximum of 2 seconds
Rated Speed	N_r	Speed at continuous power is the output
No-Load Speed	$N_{no-load}$	Maximum possible speed of motor that it can be electrically excited
Torque Constant	K_t	Ratio of the developed torque to input current
Voltage Constant	K_v	Ratio of voltage generated in the winding to rotor speed
Max. Cogging Torque	T_{cog}	Undesirable torque component arising from attractions between magnets and teeth. Cogging torque is minimized for each MDS's torque motor is less than 0.5 % of the rated torque
Torque Ripple	T_{ripple}	Undesirable torque component arising from attractions between stator MMF and magnets
Num. of Pole	$2p$	Number of poles
Rated Current	I_r	Current required to obtain the rated continuous torque
Peak Current	I_p	Current required to obtain peak torque from the motor
Line Resistance	R_{LL}	Cold (25°C) resistance measured between two leads of the winding
Line Inductance	L_{LL}	Inductance measured between two leads of the AC winding (@60Hz)
Stator Weight	W_s	Total weight of stator laminations including windings
Rotor Weight	W_r	Total weight of rotor laminations and magnets
Total Weight	W_{total}	Total weight of stator and rotor weight
Mech. Time Constant	K_{mech}	Motor mechanical dynamic capability level
Thermal Resistance	R_{th}	Ratio of winding temperature rise to average stator power loss at rated motor operation
Inertia	J	Inertia of the rotor including rotor core and magnets
Motor Constant	K_m	Ratio of peak torque to square root of input power: $K_m = T_{peak}/(P_{peak})^{.5}$. It shows the ability of a motor to convert electrical power to torque
Rotor ID		Rotor inner diameter of the motor
Stator OD		Stator outer diameter of the motor

NOTE: All performance data is obtained at 25°C ambient

Motor Parameters		Symbols	Units	TML-130-025		TML-130-050		TML-130-100	
PERFORMANCE	DC Bus Voltage	V_{DC}	V	24	48	24	48	24	48
	Rated Torque	T_r	Nm	6.4		12.4		22.2	
	Peak Torque	T_p	Nm	10		20.1		39.4	
	Rated Speed	N_r	rpm	135	380	100	270	75	200
	No-Load Speed	$N_{no-load}$	rpm	280	560	195	390	140	275
	Torque Constant	K_t	Nm/A	0.99		1.42		1.98	
	Voltage Constant	K_v	V/rpm	0.085		0.121		0.170	
	Max. Cogging Torque	T_{cog}	%			<1			
	Torque Ripple	T_{ripple}	%			<1			
	ELECTRICAL	Number of Pole	$2p$	--			24		
Rated Current		I_r	A_{rms}	6.5		8.75		11.2	
Peak Current		I_p	A_{rms}	10.4		14.6		20.4	
Line Resistance		$R_{LL}@25^{\circ}C$	Ohm	1.12 ($\pm 20\%$)		0.92 ($\pm 20\%$)		0.7 ($\pm 20\%$)	
Line Inductance		$L_{LL}@60Hz$	mH	4.90 ($\pm 30\%$)		4.62 ($\pm 30\%$)		4.47 ($\pm 30\%$)	
MECHANICAL & THERMAL	Stator Weight	W_s	kg	1.89		3.15		5.66	
	Rotor Weight	W_r	kg	0.47		0.95		1.90	
	Total Weight	W_{total}	kg	2.36		4.1		7.56	
	Mech. Time Constant	K_{mech}	ms	0.90		0.62		0.48	
	Thermal Resistance ⁽²⁾	R_{th}	$^{\circ}C/W$	0.734		0.556		0.449	
	Inertia	J	kg.m ²	0.00055		0.00111		0.00221	
	Motor Constant	K_m	Nm/ \sqrt{W}	0.67	0.40	1.09	0.66	1.68	1.03
	Rotor ID		mm			55			
	Stator OD		mm			130			

Motor Parameters		Symbols	Units	TMH-130-025		TMH-130-050		TMH-130-100	
PERFORMANCE	DC Bus Voltage	V_{DC}	V	310	560	310	560	310	560
	Rated Torque	T_r	Nm	6.4		12.6		21.9	
	Peak Torque	T_p	Nm	16.75		34.1		67	
	Rated Speed	N_r	rpm	355	725	350	685	310	605
	No-Load Speed	$N_{no-load}$	rpm	535	970	485	880	410	745
	Torque Constant	K_t	Nm/A	6.72		7.43		8.77	
	Voltage Constant	K_v	V/rpm	0.574		0.636		0.752	
	Max. Cogging Torque	T_{cog}	%			<1			
	Torque Ripple	T_{ripple}	%			<1			
	ELECTRICAL	Number of Pole	$2p$	--			24		
Rated Current		I_r	A_{rms}	0.95		1.7		2.5	
Peak Current		I_p	A_{rms}	3		5.6		9.2	
Line Resistance		$R_{LL}@25^{\circ}C$	Ohm	61.4 ($\pm 20\%$)		25 ($\pm 20\%$)		13.9 ($\pm 20\%$)	
Line Inductance		$L_{LL}@60Hz$	mH	213.9 ($\pm 30\%$)		127.3 ($\pm 30\%$)		87.6 ($\pm 30\%$)	
MECHANICAL & THERMAL	Stator Weight	W_s	kg	1.9		3.13		5.69	
	Rotor Weight	W_r	kg	0.47		0.95		1.90	
	Total Weight	W_{total}	kg	2.35		4.08		7.59	
	Mech. Time Constant	K_{mech}	ms	0.91		0.61		0.49	
	Thermal Resistance ⁽²⁾	R_{th}	$^{\circ}C/W$	0.734		0.556		0.449	
	Inertia	J	kg.m ²	0.00055		0.00111		0.00221	
	Motor Constant	K_m	Nm/ \sqrt{W}	0.41	0.29	0.59	0.42	0.82	0.59
	Rotor ID		mm			55			
	Stator OD		mm			130			

1. All performance and electrical specifications are obtained at 25°C ambient and may change $\pm 10\%$. 2. Housed version of motor mounted to 250 mm sq. x 10 mm aluminum heat sink (maximum winding temperature is 120°C). 3. Higher torque and speed values as well as dimensions on request.

TM(L/H)-130 Torque-Speed Curves

Tr: Rated Torque
Tp: Peak Torque

— @Tr 24V - - - @Tr 48V
— @Tp 24V - - - @Tp 48V

— @Tr 310V - - - @Tr 560V
— @Tp 310V - - - @Tp 560V

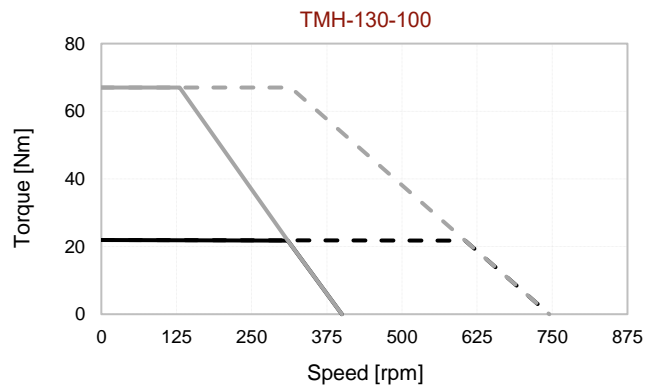
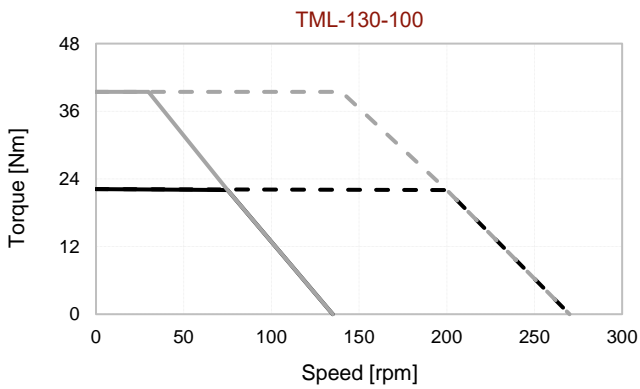
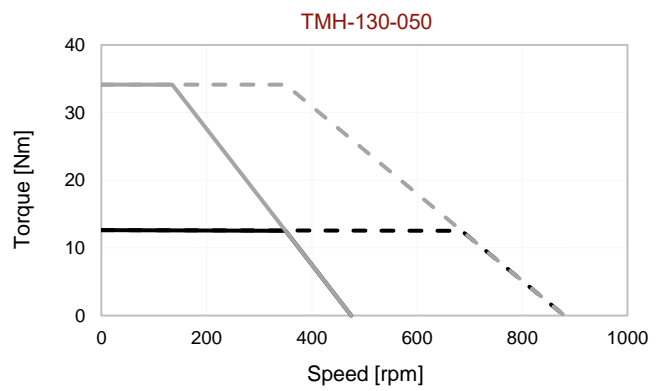
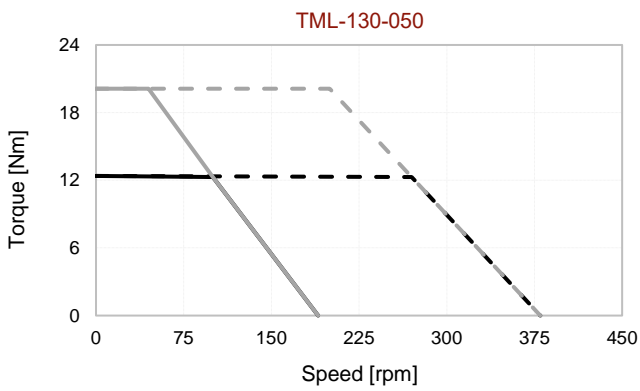
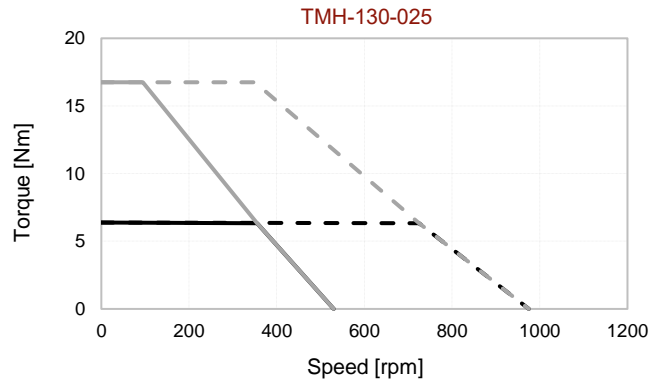
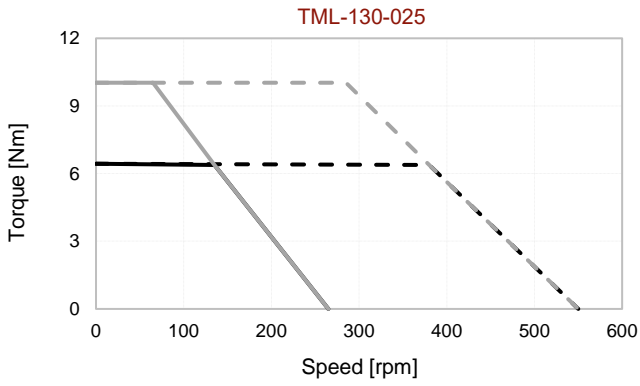

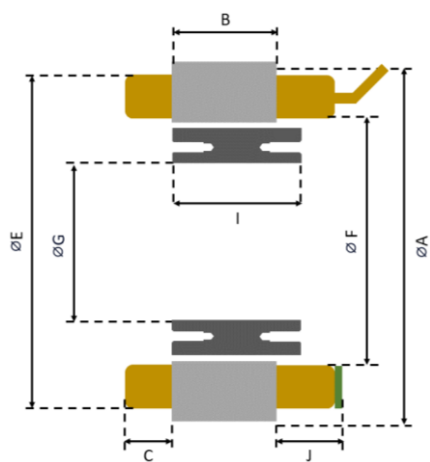
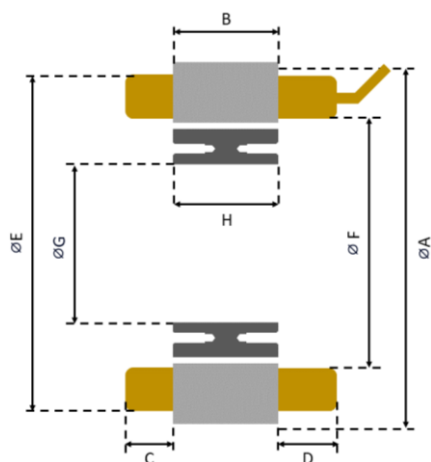

Hall Effect Sensor Option

Model	A (mm)	B (mm)	C (mm)	D (mm)	E (mm)	F (mm)	G (mm)	H (mm)	I (mm)	J (mm)
TM(L/H)-130-025	130	25	14	16	124	82.4	55	25.1	30.1	19
TM(L/H)-130-050	130	50	14	16	124	82.4	55	50.2	55.2	19
TM(L/H)-130-100	130	100	14	16	124	82.4	55	100.4	105.4	19

Notes:

MOTOR LEADS:

130-TML: #14 AWG Teflon® insulated, 500 mm (optional) length, 1-Red, 1-White, 1-Black.
 130-TMH: #18 AWG Teflon® insulated, 500 mm (optional) length, 1-Red, 1-White, 1-Black.

THERMISTOR LEADS:

#26 AWG Teflon® insulated, 500 mm (optional) length, 2-Brown or Blue

SENSOR LEADS:

#23 AWG Teflon® insulated, 500 mm (optional) length, 1-Blue, 1-Green, 1-Brown, 1-White, 1-Yellow

MOUNTING OPTION:

#Stator: 3x3 Keyway
 #Rotor: (8X on each side) M4 Bolt Hole (For details refer to MDS Motor mounting documents)

Motor Parameters		Symbols	Units	TML-150-025		TML-150-050		TML-150-100	
PERFORMANCE	DC Bus Voltage	V_{DC}	V	24	48	24	48	24	48
	Rated Torque	T_r	Nm	8.9		17.4		31.7	
	Peak Torque	T_p	Nm	14.75		29.75		59.25	
	Rated Speed	N_r	rpm	130	350	85	225	60	165
	No-Load Speed	$N_{no-load}$	rpm	245	495	155	320	115	225
	Torque Constant	K_t	Nm/A	1.12		1.73		2.42	
	Voltage Constant	K_v	V/rpm	0.096		0.148		0.208	
	Max. Cogging Torque	T_{cog}	%			<1			
	Torque Ripple	T_{ripple}	%			<1			
	ELECTRICAL	Number of Pole	$2p$	--			24		
Rated Current		I_r	A_{rms}	8		10.1		13.1	
Peak Current		I_p	A_{rms}	13.4		17.6		25	
Line Resistance		$R_{LL}@25^{\circ}C$	Ohm	0.85 ($\pm 20\%$)		0.8 ($\pm 20\%$)		0.62 ($\pm 20\%$)	
Line Inductance		$L_{LL}@60Hz$	mH	3.81 ($\pm 30\%$)		4.35 ($\pm 30\%$)		4.19 ($\pm 30\%$)	
MECHANICAL & THERMAL	Stator Weight	W_s	kg	2.32		3.92		7.02	
	Rotor Weight	W_r	kg	0.66		1.32		2.65	
	Total Weight	W_{total}	kg	2.98		5.24		9.67	
	Mech. Time Constant	K_{mech}	ms	1.10		0.77		0.61	
	Thermal Resistance ⁽²⁾	R_{th}	$^{\circ}C/W$	0.656		0.490		0.373	
	Inertia	J	kg.m ²	0.00119		0.00228		0.00477	
	Motor Constant	K_m	Nm/ \sqrt{W}	0.81	0.50	1.40	0.81	0.50	1.40
	Rotor ID		mm			70			
	Stator OD		mm			150			

Motor Parameters		Symbols	Units	TMH-150-025		TMH-150-050		TMH-150-100	
PERFORMANCE	DC Bus Voltage	V_{DC}	V	310	560	310	560	310	560
	Rated Torque	T_r	Nm	9		17.3		31.4	
	Peak Torque	T_p	Nm	25.85		51.75		102.9	
	Rated Speed	N_r	rpm	330	665	310	610	290	560
	No-Load Speed	$N_{no-load}$	rpm	475	865	415	750	370	670
	Torque Constant	K_t	Nm/A	7.57		8.65		9.69	
	Voltage Constant	K_v	V/rpm	0.647		0.741		0.829	
	Max. Cogging Torque	T_{cog}	%			<1			
	Torque Ripple	T_{ripple}	%			<1			
	ELECTRICAL	Number of Pole	$2p$	--			24		
Rated Current		I_r	A_{rms}	1.2		2		3.25	
Peak Current		I_p	A_{rms}	4		7		12.4	
Line Resistance		$R_{LL}@25^{\circ}C$	Ohm	44 ($\pm 20\%$)		19.8 ($\pm 20\%$)		9.8 ($\pm 20\%$)	
Line Inductance		$L_{LL}@60Hz$	mH	172.3 ($\pm 30\%$)		108.7 ($\pm 30\%$)		67.1 ($\pm 30\%$)	
MECHANICAL & THERMAL	Stator Weight	W_s	kg	2.32		3.9		7.05	
	Rotor Weight	W_r	kg	0.66		1.32		2.65	
	Total Weight	W_{total}	kg	2.98		5.22		9.70	
	Mech. Time Constant	K_{mech}	ms	1.12		0.77		0.61	
	Thermal Resistance ⁽²⁾	R_{th}	$^{\circ}C/W$	0.656		0.490		0.373	
	Inertia	J	kg.m ²	0.00119		0.00228		0.00477	
	Motor Constant	K_m	Nm/ \sqrt{W}	0.51	0.36	0.73	0.51	0.36	0.73
	Rotor ID		mm			70			
	Stator OD		mm			150			

1. All performance and electrical specifications are obtained at 25°C ambient and may change $\pm 10\%$. 2. Housed version of motor mounted to 290 mm sq. x 10 mm aluminum heat sink (maximum winding temperature is 120°C). 3. Higher torque and speed values as well as dimensions on request.

TM(L/H)-150 Torque-Speed Curves

Tr: Rated Torque
Tp: Peak Torque

— @Tr 24V - - - @Tr 48V
— @Tp 24V - - - @Tp 48V

— @Tr 310V - - - @Tr 560V
— @Tp 310V - - - @Tp 560V

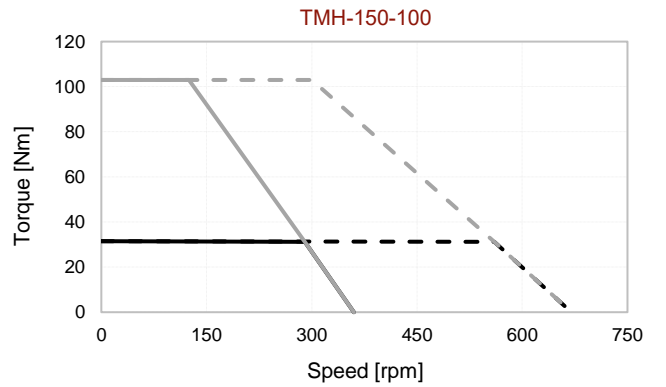
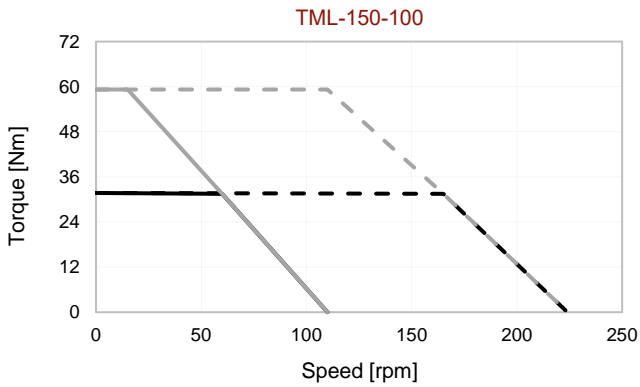
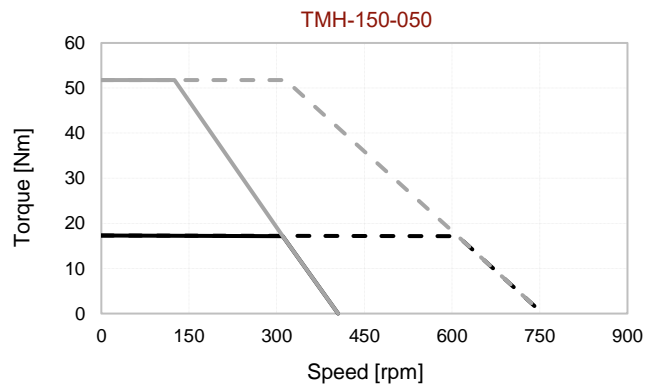
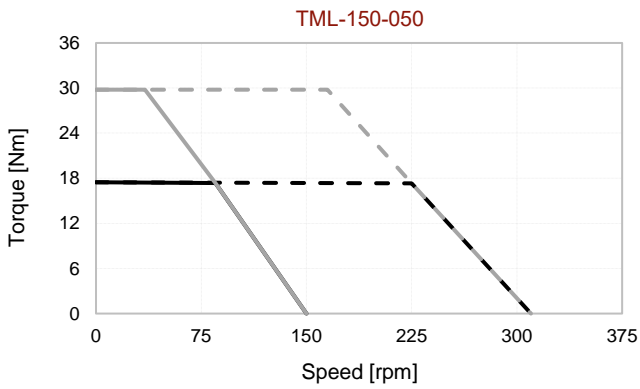
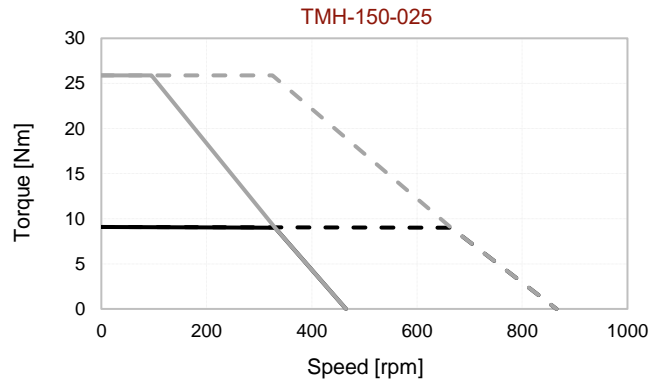
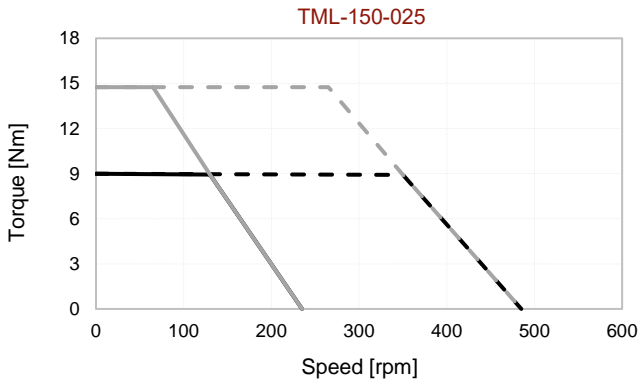

TM(L/H)-150 Outline Drawing

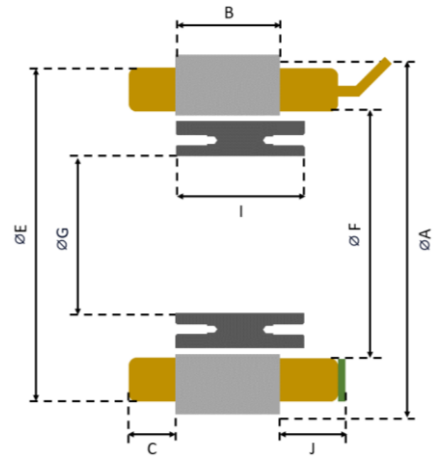
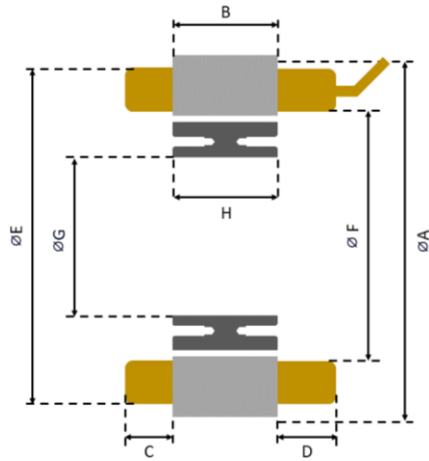

Hall Effect Sensor Option

Model	A (mm)	B (mm)	C (mm)	D (mm)	E (mm)	F (mm)	G (mm)	H (mm)	I (mm)	J (mm)
TM(L/H)-150-025	150	25	14	16	142	100.5	70	25.1	30.1	19
TM(L/H)-150-050	150	50	14	16	142	100.5	70	50.2	55.2	19
TM(L/H)-150-100	150	100	14	16	142	100.5	70	100.4	105.4	19

Notes:

MOTOR LEADS:

150-TML: #13 AWG Teflon® insulated, 500 mm (optional) length, 1-Red, 1-White, 1-Black.
 150-TMH: #17 AWG Teflon® insulated, 500 mm (optional) length, 1-Red, 1-White, 1-Black.

THERMISTOR LEADS:

#26 AWG Teflon® insulated, 500 mm (optional) length, 2-Brown or Blue.

SENSOR LEADS:

#23 AWG Teflon® insulated, 500 mm (optional) length, 1-Blue, 1-Green, 1-Brown, 1-White, 1-Yellow.

MOUNTING OPTION:

#Stator: 3x3 Keyway

#Rotor: (8X on each side) M4 Bolt Hole (For details refer to MDS Motor mounting documents)

Motor Parameters		Symbols	Units	TML-160-025		TML-160-050		TML-160-100	
PERFORMANCE	DC Bus Voltage	V_{DC}	V	24	48	24	48	24	48
	Rated Torque	T_r	Nm	10.8		21.7		40.2	
	Peak Torque	T_p	Nm	18		35.8		72.3	
	Rated Speed	N_r	rpm	125	315	75	195	50	140
	No-Load Speed	$N_{no-load}$	rpm	220	440	135	275	95	195
	Torque Constant	K_t	Nm/A	1.26		2.01		2.81	
	Voltage Constant	K_v	V/rpm	0.108		0.172		0.241	
	Max. Cogging Torque	T_{cog}	%			<1			
	Torque Ripple	T_{ripple}	%			<1			
	ELECTRICAL	Number of Pole	$2p$	--			24		
Rated Current		I_r	A_{rms}	8.6		10.8		14.3	
Peak Current		I_p	A_{rms}	14.4		18		26	
Line Resistance		$R_{LL}@25^{\circ}C$	Ohm	0.75 ($\pm 20\%$)		0.72 ($\pm 20\%$)		0.58 ($\pm 20\%$)	
Line Inductance		$L_{LL}@60Hz$	mH	3.75 ($\pm 30\%$)		4.3 ($\pm 30\%$)		4.34 ($\pm 30\%$)	
MECHANICAL & THERMAL	Stator Weight	W_s	kg	2.4		4.01		7.19	
	Rotor Weight	W_r	kg	0.80		1.60		3.22	
	Total Weight	W_{total}	kg	3.20		5.61		10.31	
	Mech. Time Constant	K_{mech}	ms	1.16		0.82		0.66	
	Thermal Resistance ⁽²⁾	R_{th}	$^{\circ}C/W$	0.595		0.448		0.367	
	Inertia	J	kg.m ²	0.00183		0.00369		0.00741	
	Motor Constant	K_m	Nm/ \sqrt{W}	0.91	0.57	1.66	1.03	2.77	1.66
	Rotor ID		mm			80			
	Stator OD		mm			160			

Motor Parameters		Symbols	Units	TMH-160-025		TMH-160-050		TMH-160-100	
PERFORMANCE	DC Bus Voltage	V_{DC}	V	310	560	310	560	310	560
	Rated Torque	T_r	Nm	11.2		21.7		40.6	
	Peak Torque	T_p	Nm	33.7		65.4		133.6	
	Rated Speed	N_r	rpm	325	650	285	555	260	495
	No-Load Speed	$N_{no-load}$	rpm	460	835	375	685	330	595
	Torque Constant	K_t	Nm/A	7.79		9.45		10.85	
	Voltage Constant	K_v	V/rpm	0.666		0.809		0.929	
	Max. Cogging Torque	T_{cog}	%			<1			
	Torque Ripple	T_{ripple}	%			<1			
	ELECTRICAL	Number of Pole	$2p$	--			24		
Rated Current		I_r	A_{rms}	1.45		2.3		3.75	
Peak Current		I_p	A_{rms}	4.8		7.6		13.6	
Line Resistance		$R_{LL}@25^{\circ}C$	Ohm	31.6 ($\pm 20\%$)		16.5 ($\pm 20\%$)		8.23 ($\pm 20\%$)	
Line Inductance		$L_{LL}@60Hz$	mH	155.2 ($\pm 30\%$)		103.3 ($\pm 30\%$)		64.6 ($\pm 30\%$)	
MECHANICAL & THERMAL	Stator Weight	W_s	kg	2.34		3.98		7.24	
	Rotor Weight	W_r	kg	0.80		1.60		3.22	
	Total Weight	W_{total}	kg	3.14		5.58		10.46	
	Mech. Time Constant	K_{mech}	ms	1.16		0.83		0.64	
	Thermal Resistance ⁽²⁾	R_{th}	$^{\circ}C/W$	0.595		0.448		0.367	
	Inertia	J	kg.m ²	0.00183		0.00369		0.00741	
	Motor Constant	K_m	Nm/ \sqrt{W}	0.58	0.41	0.85	0.58	0.41	0.85
	Rotor ID		mm			80			
	Stator OD		mm			160			

1. All performance and electrical specifications are obtained at 25°C ambient and may change $\pm 10\%$. 2. Housed version of motor mounted to 300 mm sq. x 15 mm aluminum heat sink (maximum winding temperature is 120°C). 3. Higher torque and speed values as well as dimensions on request.

TM(L/H)-160 Torque-Speed Curves

Tr: Rated Torque
Tp: Peak Torque

— @Tr 24V - - - @Tr 48V
— @Tp 24V - - - @Tp 48V

— @Tr 310V - - - @Tr 560V
— @Tp 310V - - - @Tp 560V

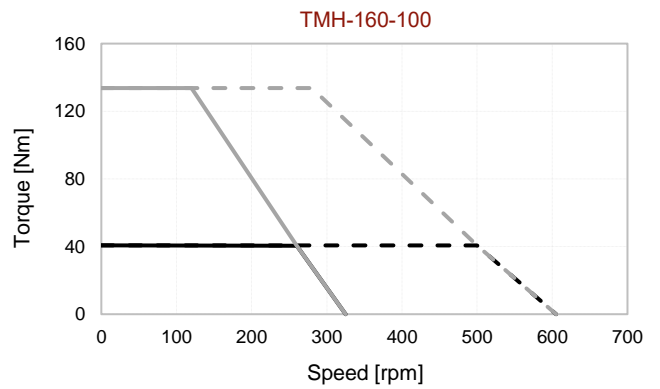
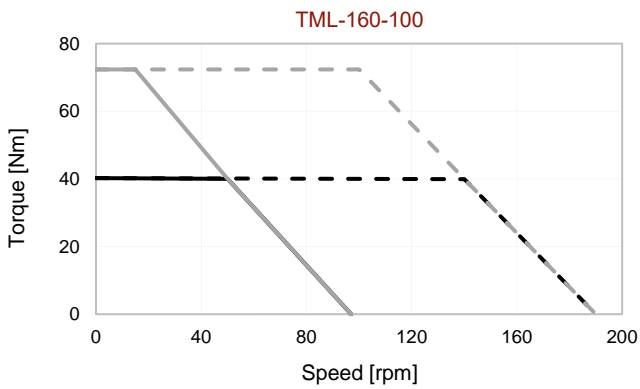
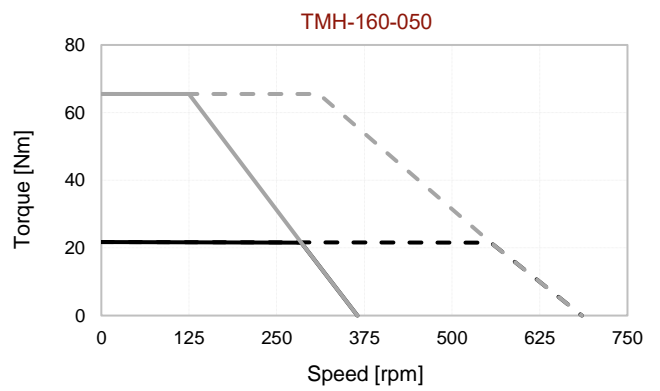
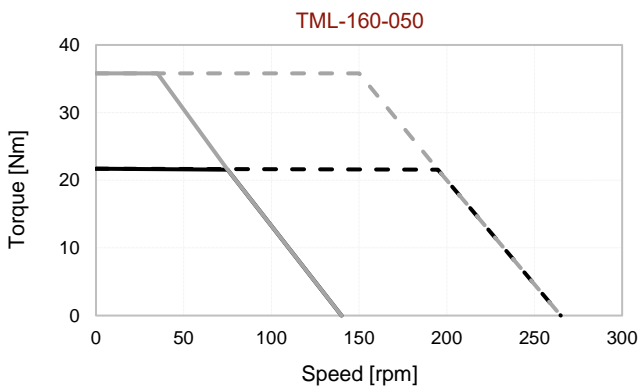
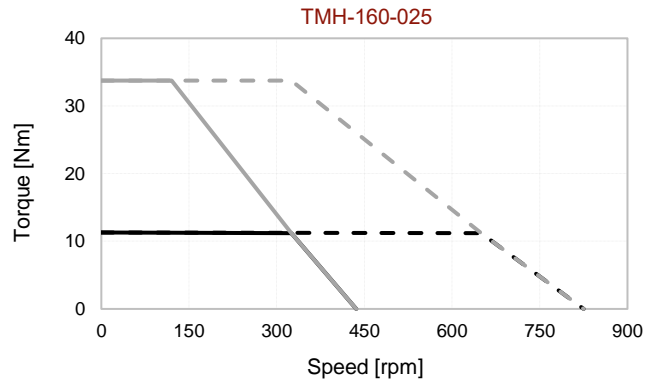
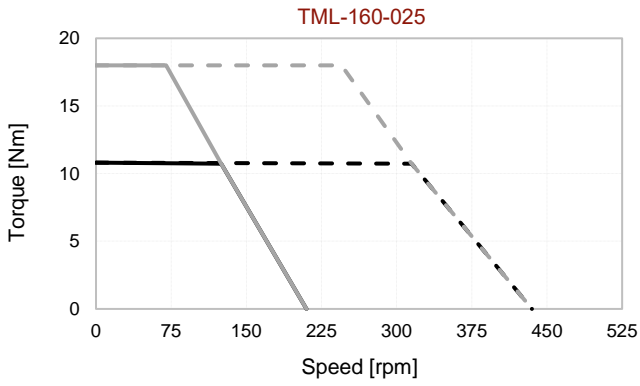

TM(L/H)-160 Outline Drawing

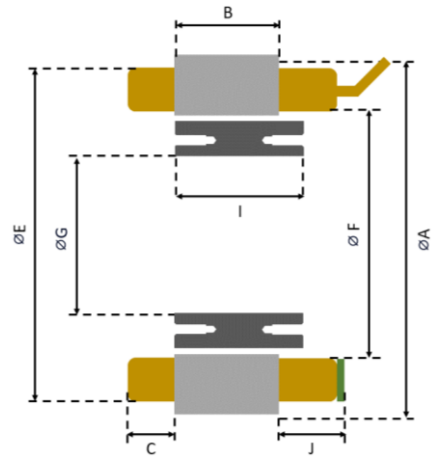
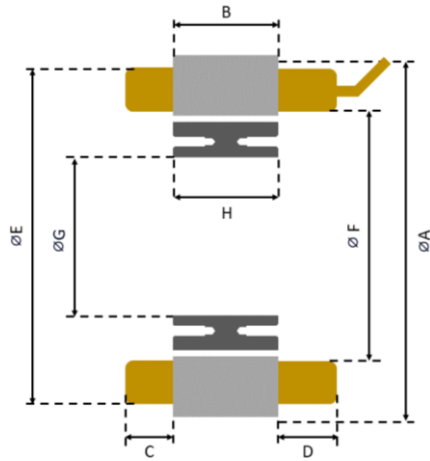

Hall Effect Sensor Option

Model	A (mm)	B (mm)	C (mm)	D (mm)	E (mm)	F (mm)	G (mm)	H (mm)	I (mm)	J (mm)
TM(L/H)-160-025	160	25	15	17	154	112.3	80	25.1	30.1	20
TM(L/H)-160-050	160	50	15	17	154	112.3	80	50.2	55.2	20
TM(L/H)-160-100	160	100	15	17	154	112.3	80	100.4	105.4	20

Notes:

MOTOR LEADS:

160-TML: #13 AWG Teflon® insulated, 500 mm (optional) length, 1-Red, 1-White, 1-Black.
 160-TMH: #16 AWG Teflon® insulated, 500 mm (optional) length, 1-Red, 1-White, 1-Black.

THERMISTOR LEADS:

#26 AWG Teflon® insulated, 500 mm (optional) length, 2-Brown or Blue.

SENSOR LEADS:

#23 AWG Teflon® insulated, 500 mm (optional) length, 1-Blue, 1-Green, 1-Brown, 1-White, 1-Yellow.

MOUNTING OPTION:

#Stator: 3x3 Keyway
 #Rotor: (8X on each side) M5 Bolt Hole (For details refer to MDS Motor mounting documents)

Motor Parameters		Symbols	Units	TML-175-030		TML-175-060		TML-175-120	
PERFORMANCE	DC Bus Voltage	V_{DC}	V	24	48	24	48	24	48
	Rated Torque	T_r	Nm	15.1		29.5		55.2	
	Peak Torque	T_p	Nm	24.9		50.6		99.3	
	Rated Speed	N_r	rpm	130	320	80	200	50	130
	No-Load Speed	$N_{no-load}$	rpm	215	435	130	270	85	175
	Torque Constant	K_t	Nm/A	1.27		2.03		3.04	
	Voltage Constant	K_v	V/rpm	0.109		0.174		0.261	
	Max. Cogging Torque	T_{cog}	%			<1			
	Torque Ripple	T_{ripple}	%			<1			
	ELECTRICAL	Number of Pole	$2p$	--			24		
Rated Current		I_r	A_{rms}	12		14.6		18.2	
Peak Current		I_p	A_{rms}	20		25.4		33.2	
Line Resistance		$R_{LL}@25^{\circ}C$	Ohm	0.52 ($\pm 20\%$)		0.47 ($\pm 20\%$)		0.42 ($\pm 20\%$)	
Line Inductance		$L_{LL}@60Hz$	mH	2.93 ($\pm 30\%$)		3.44 ($\pm 30\%$)		3.69 ($\pm 30\%$)	
MECHANICAL & THERMAL	Stator Weight	W_s	kg	3.66		6.39		11.77	
	Rotor Weight	W_r	kg	1.04		2.10		4.19	
	Total Weight	W_{total}	kg	4.70		8.49		15.96	
	Mech. Time Constant	K_{mech}	ms	1.10		0.78		0.63	
	Thermal Resistance ⁽²⁾	R_{th}	$^{\circ}C/W$	0.558		0.416		0.290	
	Inertia	J	kg.m ²	0.00279		0.00562		0.01128	
	Motor Constant	K_m	Nm/ \sqrt{W}	1.06	0.67	1.88	1.06	0.67	1.88
	Rotor ID		mm			88			
Stator OD		mm			175				

Motor Parameters		Symbols	Units	TMH-175-030		TMH-175-060		TMH-175-120	
PERFORMANCE	DC Bus Voltage	V_{DC}	V	310	560	310	560	310	560
	Rated Torque	T_r	Nm	15		29		55.9	
	Peak Torque	T_p	Nm	44.4		88.7		181.2	
	Rated Speed	N_r	rpm	315	615	260	505	230	445
	No-Load Speed	$N_{no-load}$	rpm	425	775	335	615	290	530
	Torque Constant	K_t	Nm/A	8.36		10.56		12.16	
	Voltage Constant	K_v	V/rpm	0.717		0.902		1.043	
	Max. Cogging Torque	T_{cog}	%			<1			
	Torque Ripple	T_{ripple}	%			<1			
	ELECTRICAL	Number of Pole	$2p$	--			24		
Rated Current		I_r	A_{rms}	1.8		2.75		4.6	
Peak Current		I_p	A_{rms}	6		9.6		16.8	
Line Resistance		$R_{LL}@25^{\circ}C$	Ohm	22.7 ($\pm 20\%$)		13.14 ($\pm 20\%$)		6.74 ($\pm 20\%$)	
Line Inductance		$L_{LL}@60Hz$	mH	127.9 ($\pm 30\%$)		92.7 ($\pm 30\%$)		59.2 ($\pm 30\%$)	
MECHANICAL & THERMAL	Stator Weight	W_s	kg	3.62		6.38		11.87	
	Rotor Weight	W_r	kg	1.04		2.10		4.19	
	Total Weight	W_{total}	kg	4.66		8.48		16.06	
	Mech. Time Constant	K_{mech}	ms	1.10		0.81		0.62	
	Thermal Resistance ⁽²⁾	R_{th}	$^{\circ}C/W$	0.558		0.416		0.290	
	Inertia	J	kg.m ²	0.00279		0.00562		0.01128	
	Motor Constant	K_m	Nm/ \sqrt{W}	0.68	0.48	1.03	0.68	0.48	1.03
	Rotor ID		mm			88			
Stator OD		mm			175				

1. All performance and electrical specifications are obtained at 25°C ambient and may change $\pm 10\%$. 2. Housed version of motor mounted to 300 mm sq. x 15 mm aluminum heat sink (maximum winding temperature is 120°C). 3. Higher torque and speed values as well as dimensions on request.

TM(L/H)-175 Torque-Speed Curves

Tr: Rated Torque
Tp: Peak Torque

— @Tr 24V - - - @Tr 48V
— @Tp 24V - - - @Tp 48V

— @Tr 310V - - - @Tr 560V
— @Tp 310V - - - @Tp 560V

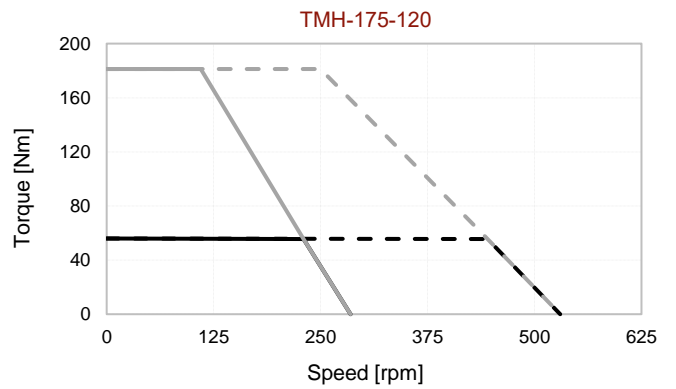
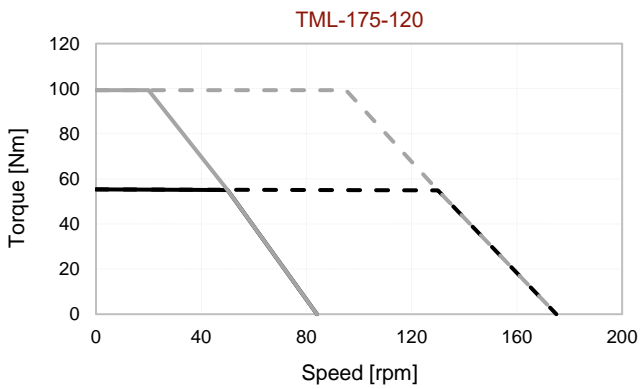
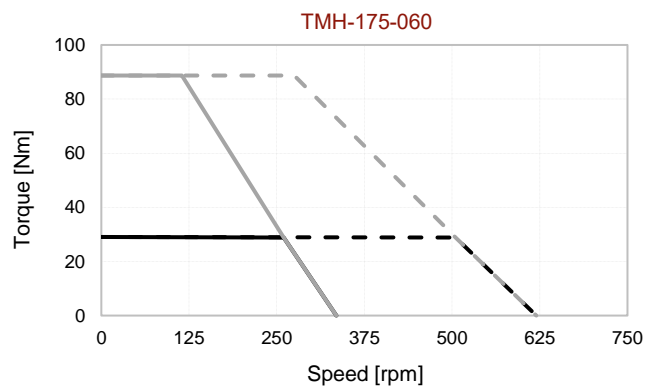
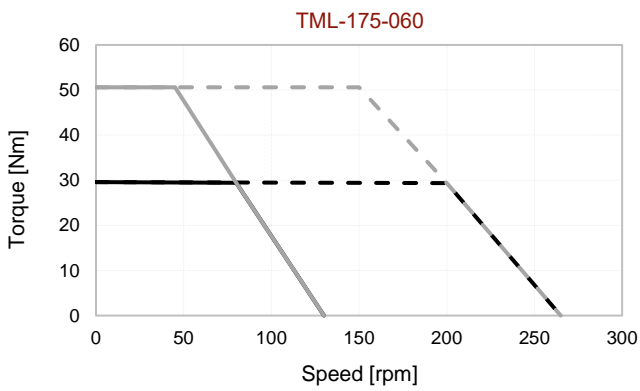
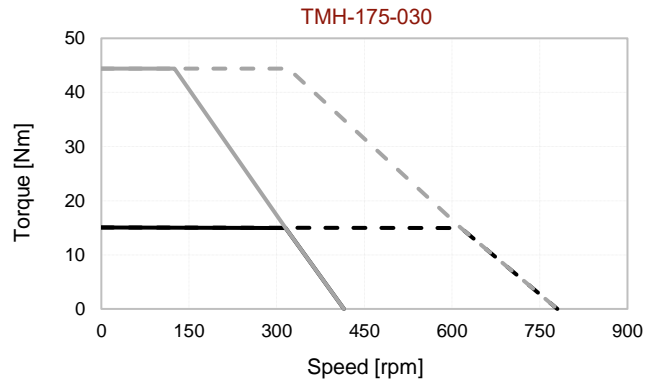
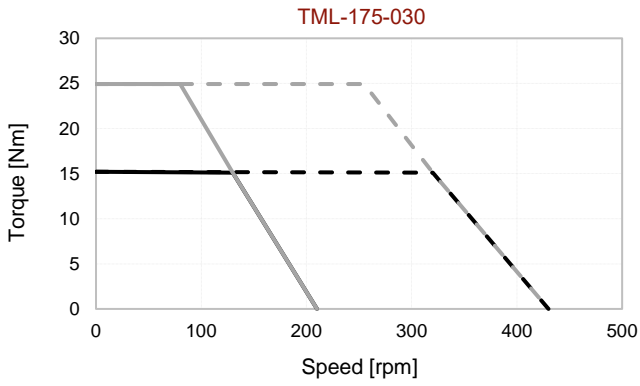

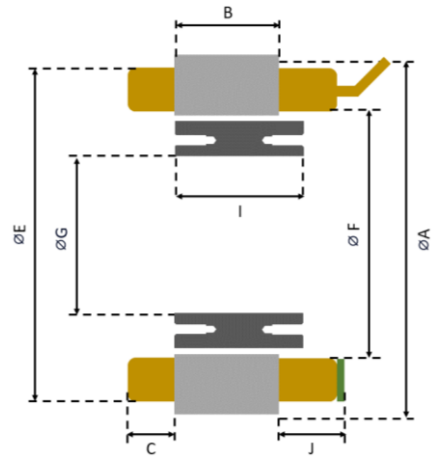
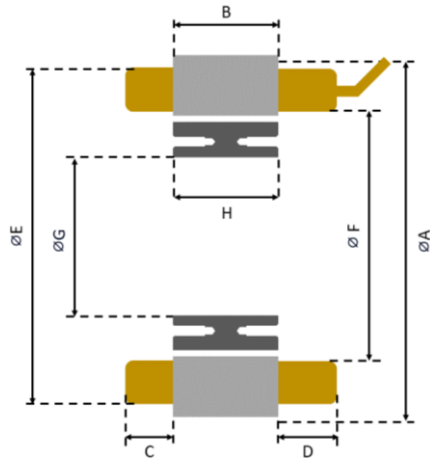

Hall Effect Sensor Option

Model	A (mm)	B (mm)	C (mm)	D (mm)	E (mm)	F (mm)	G (mm)	H (mm)	I (mm)	J (mm)
TM(L/H)-175-030	175	30	15	17	166	120.5	88	30.1	35.1	20
TM(L/H)-175-060	175	60	15	17	166	120.5	88	60.2	65.2	20
TM(L/H)-175-120	175	120	15	17	166	120.5	88	120.4	125.4	20

Notes:

MOTOR LEADS:

175-TML: #12 AWG Teflon® insulated, 500 mm (optional) length, 1-Red, 1-White, 1-Black.
 175-TMH: #15 AWG Teflon® insulated, 500 mm (optional) length, 1-Red, 1-White, 1-Black.

THERMISTOR LEADS:

#26 AWG Teflon® insulated, 500 mm (optional) length, 2-Brown or Blue.

SENSOR LEADS:

#23 AWG Teflon® insulated, 500 mm (optional) length, 1-Blue, 1-Green, 1-Brown, 1-White, 1-Yellow.

MOUNTING OPTION:

#Stator: 3x3 Keyway
 #Rotor: (8X on each side) M5 Bolt Hole (For details refer to MDS Motor mounting documents)

TRM-200 Technical Information

Motor Parameters		Symbols	Units	TML-200-030		TML-200-060		TML-200-120	
PERFORMANCE	DC Bus Voltage	V_{DC}	V	24	48	24	48	24	48
	Rated Torque	T_r	Nm	19.7		34.8		70.1	
	Peak Torque	T_p	Nm	31.3		62.9		129.1	
	Rated Speed	N_r	rpm	115	275	70	175	40	105
	No-Load Speed	$N_{no-load}$	rpm	170	350	105	220	65	135
	Torque Constant	K_t	Nm/A	1.58		2.49		3.92	
	Voltage Constant	K_v	V/rpm	0.135		0.213		0.341	
	Max. Cogging Torque	T_{cog}	%			<1			
	Torque Ripple	T_{ripple}	%			<1			
	ELECTRICAL	Number of Pole	$2p$	--			24		
Rated Current		I_r	A_{rms}	12.5		14		17.9	
Peak Current		I_p	A_{rms}	20		25.4		32.6	
Line Resistance		$R_{LL}@25^{\circ}C$	Ohm	0.42 ($\pm 20\%$)		0.42 ($\pm 20\%$)		0.41 ($\pm 20\%$)	
Line Inductance		$L_{LL}@60Hz$	mH	2.30 ($\pm 30\%$)		2.4 ($\pm 30\%$)		3.44 ($\pm 30\%$)	
MECHANICAL & THERMAL	Stator Weight	W_s	kg	3.16		5.58		10.34	
	Rotor Weight	W_r	kg	1.59		3.19		6.39	
	Total Weight	W_{total}	kg	4.75		8.77		16.73	
	Mech. Time Constant	K_{mech}	ms	1.61		1.19		0.97	
	Thermal Resistance ⁽²⁾	R_{th}	$^{\circ}C/W$	0.608		0.410		0.316	
	Inertia	J	kg.m ²	0.00751		0.01512		0.03034	
	Motor Constant	K_m	Nm/ \sqrt{W}	1.28	0.83	2.18	1.38	4.09	2.53
	Rotor ID		mm			120			
	Stator OD		mm			200			

Motor Parameters		Symbols	Units	TMH-200-030		TMH-200-060		TMH-200-120	
PERFORMANCE	DC Bus Voltage	V_{DC}	V	310	560	310	560	310	560
	Rated Torque	T_r	Nm	19.2		35.2		68.2	
	Peak Torque	T_p	Nm	59.5		121.9		242.3	
	Rated Speed	N_r	rpm	295	570	255	490	215	410
	No-Load Speed	$N_{no-load}$	rpm	370	675	315	575	255	465
	Torque Constant	K_t	Nm/A	9.63		11.36		13.93	
	Voltage Constant	K_v	V/rpm	0.823		0.965		1.192	
	Max. Cogging Torque	T_{cog}	%			<1			
	Torque Ripple	T_{ripple}	%			<1			
	ELECTRICAL	Number of Pole	$2p$	--			24		
Rated Current		I_r	A_{rms}	2		3.1		4.9	
Peak Current		I_p	A_{rms}	6.4		11.2		18	
Line Resistance		$R_{LL}@25^{\circ}C$	Ohm	16.2 ($\pm 20\%$)		10.1 ($\pm 20\%$)		5.14 ($\pm 20\%$)	
Line Inductance		$L_{LL}@60Hz$	mH	88.6 ($\pm 30\%$)		60.4 ($\pm 30\%$)		40.6 ($\pm 30\%$)	
MECHANICAL & THERMAL	Stator Weight	W_s	kg	3.13		5.47		10.17	
	Rotor Weight	W_r	kg	1.59		3.19		6.39	
	Total Weight	W_{total}	kg	4.72		8.66		16.56	
	Mech. Time Constant	K_{mech}	ms	1.60		1.45		0.98	
	Thermal Resistance ⁽²⁾	R_{th}	$^{\circ}C/W$	0.608		0.410		0.316	
	Inertia	J	kg.m ²	0.00751		0.01512		0.03034	
	Motor Constant	K_m	Nm/ \sqrt{W}	0.79	0.57	1.15	0.83	1.74	1.26
	Rotor ID		mm			120			
	Stator OD		mm			200			

1. All performance and electrical specifications are obtained at 25°C ambient and may change $\pm 10\%$. 2. Housed version of motor mounted to 300 mm sq. x 15 mm aluminum heat sink (maximum winding temperature is 120°C). 3. Higher torque and speed values as well as dimensions on request.

TM(L/H)-200 Torque-Speed Curves

Tr: Rated Torque
Tp: Peak Torque

— @Tr 24V - - - @Tr 48V
— @Tp 24V - - - @Tp 48V

— @Tr 310V - - - @Tr 560V
— @Tp 310V - - - @Tp 560V

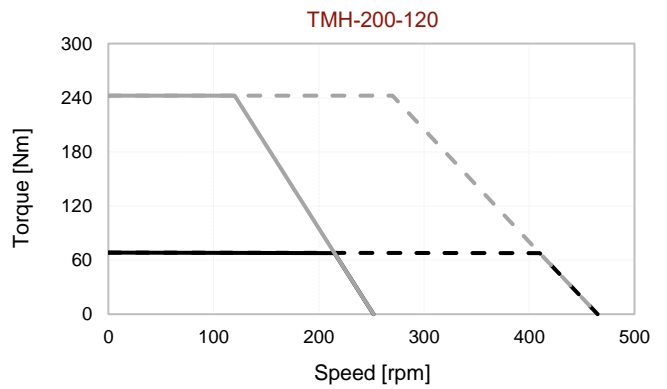
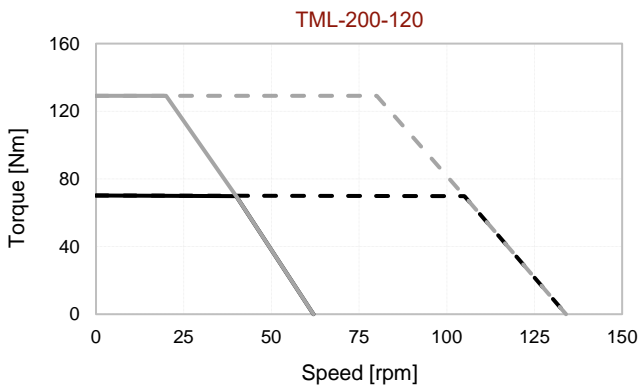
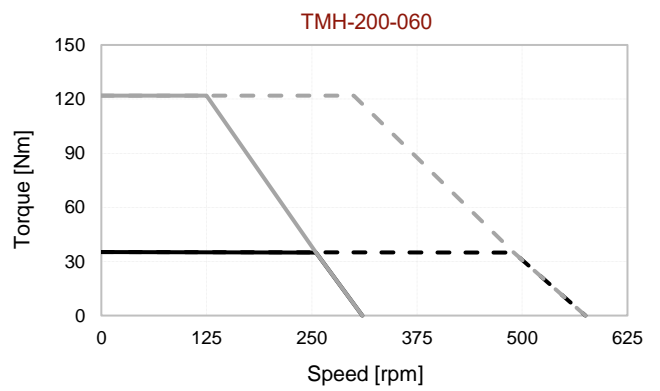
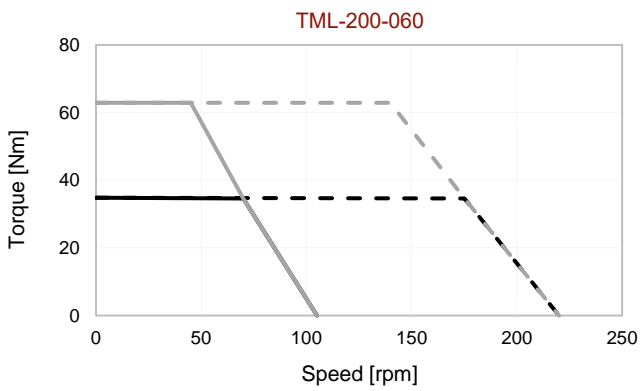
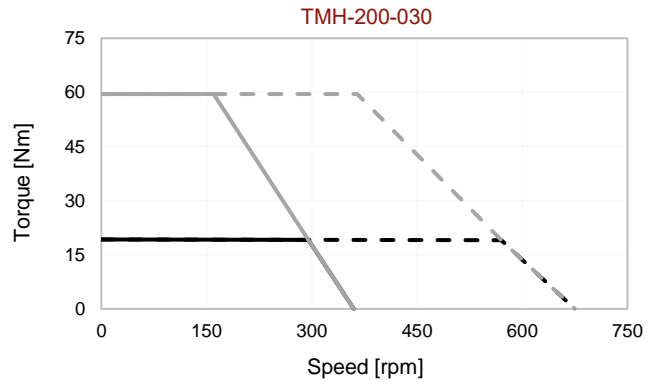
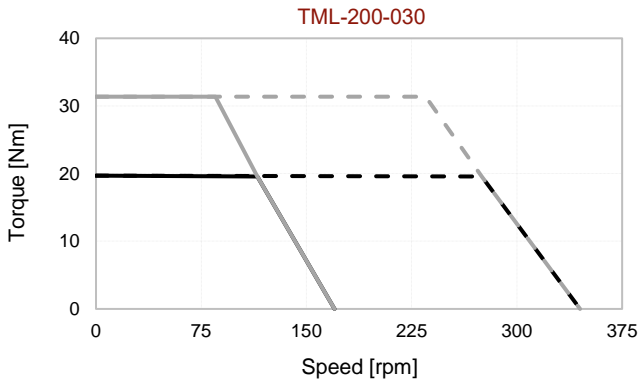

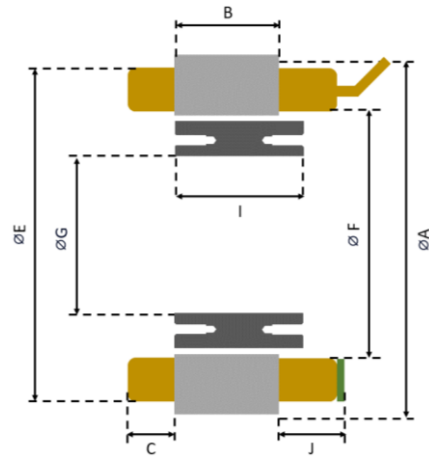
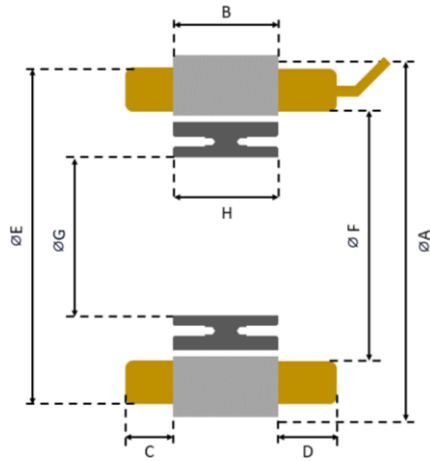

Hall Effect Sensor Option

Model	A (mm)	B (mm)	C (mm)	D (mm)	E (mm)	F (mm)	G (mm)	H (mm)	I (mm)	J (mm)
TM(L/H)-200-030	200	30	15	17	193	156.5	120	30.1	35.1	20
TM(L/H)-200-060	200	60	15	17	193	156.5	120	60.2	65.2	20
TM(L/H)-200-120	200	120	15	17	193	156.5	120	120.4	125.4	20

Notes:

MOTOR LEADS:

200-TML: #12 AWG Teflon® insulated, 500 mm (optional) length, 1-Red, 1-White, 1-Black.
 200-TMH: #15 AWG Teflon® insulated, 500 mm (optional) length, 1-Red, 1-White, 1-Black.

THERMISTOR LEADS:

#26 AWG Teflon® insulated, 500 mm (optional) length, 2-Brown or Blue.

SENSOR LEADS:

#23 AWG Teflon® insulated, 500 mm (optional) length, 1-Blue, 1-Green, 1-Brown, 1-White, 1-Yellow.

MOUNTING OPTION:

#Stator: 3x3 Keyway
 #Rotor: (12X on each side) M5 Bolt Hole (For details refer to MDS Motor mounting documents)

Motor Parameters		Symbols	Units	TML-230-030		TML-230-060		TML-230-120	
PERFORMANCE	DC Bus Voltage	V_{DC}	V	24	48	24	48	24	48
	Rated Torque	T_r	Nm	28.9		55.8		97.2	
	Peak Torque	T_p	Nm	45.8		92.5		183.9	
	Rated Speed	N_r	rpm	105	255	70	165	40	100
	No-Load Speed	$N_{no-load}$	rpm	160	325	100	210	60	125
	Torque Constant	K_t	Nm/A	1.71		2.63		4.21	
	Voltage Constant	K_v	V/rpm	0.146		0.225		0.36	
	Max. Cogging Torque	T_{cog}	%			<1			
	Torque Ripple	T_{ripple}	%			<1			
	ELECTRICAL	Number of Pole	$2p$	--			32		
Rated Current		I_r	A_{rms}	16.9		21.2		23.1	
Peak Current		I_p	A_{rms}	27		35.4		44	
Line Resistance		$R_{LL}@25^{\circ}C$	Ohm	0.32 ($\pm 20\%$)		0.26 ($\pm 20\%$)		0.28 ($\pm 20\%$)	
Line Inductance		$L_{LL}@60Hz$	mH	1.64 ($\pm 30\%$)		1.79 ($\pm 30\%$)		2.15 ($\pm 30\%$)	
MECHANICAL & THERMAL	Stator Weight	W_s	kg	3.74		6.7		12.53	
	Rotor Weight	W_r	kg	1.89		3.81		7.65	
	Total Weight	W_{total}	kg	5.63		10.51		20.18	
	Mech. Time Constant	K_{mech}	ms	1.69		1.22		1.03	
	Thermal Resistance ⁽²⁾	R_{th}	$^{\circ}C/W$	0.439		0.321		0.248	
	Inertia	J	kg.m ²	0.0130		0.02620		0.05260	
	Motor Constant	K_m	Nm/ \sqrt{W}	1.62	1.04	2.76	1.8	4.82	3.05
	Rotor ID		mm			148			
	Stator OD		mm			230			

Motor Parameters		Symbols	Units	TMH-230-030		TMH-230-060		TMH-230-120	
PERFORMANCE	DC Bus Voltage	V_{DC}	V	310	560	310	560	310	560
	Rated Torque	T_r	Nm	29		55.6		95.9	
	Peak Torque	T_p	Nm	95.8		192.8		384.7	
	Rated Speed	N_r	rpm	285	545	255	485	205	385
	No-Load Speed	$N_{no-load}$	rpm	355	650	305	560	240	440
	Torque Constant	K_t	Nm/A	10		11.58		14.76	
	Voltage Constant	K_v	V/rpm	0.855		0.99		1.26	
	Max. Cogging Torque	T_{cog}	%			<1			
	Torque Ripple	T_{ripple}	%			<1			
	ELECTRICAL	Number of Pole	$2p$	--			32		
Rated Current		I_r	A_{rms}	2.9		4.8		6.5	
Peak Current		I_p	A_{rms}	10.35		18		27.9	
Line Resistance		$R_{LL}@25^{\circ}C$	Ohm	10.48 ($\pm 20\%$)		5.26 ($\pm 20\%$)		3.62 ($\pm 20\%$)	
Line Inductance		$L_{LL}@60Hz$	mH	56.5 ($\pm 30\%$)		34.9 ($\pm 30\%$)		26.9 ($\pm 30\%$)	
MECHANICAL & THERMAL	Stator Weight	W_s	kg	4.32		6.81		12.57	
	Rotor Weight	W_r	kg	1.89		3.81		7.65	
	Total Weight	W_{total}	kg	6.21		10.62		20.22	
	Mech. Time Constant	K_{mech}	ms	1.67		1.26		1.07	
	Thermal Resistance ⁽²⁾	R_{th}	$^{\circ}C/W$	0.439		0.321		0.248	
	Inertia	J	kg.m ²	0.0130		0.02620		0.05260	
	Motor Constant	K_m	Nm/ \sqrt{W}	0.99	0.71	1.44	1.05	2.11	1.54
	Rotor ID		mm			148			
	Stator OD		mm			230			

1. All performance and electrical specifications are obtained at 25°C ambient and may change $\pm 10\%$. 2. Housed version of motor mounted to 340 mm sq. x 15 mm aluminum heat sink (maximum winding temperature is 120°C). 3. Higher torque and speed values as well as dimensions on request.

TM(L/H)-230 Torque-Speed Curves

Tr: Rated Torque
Tp: Peak Torque

— @Tr 24V - - - @Tr 48V
— @Tp 24V - - - @Tp 48V

— @Tr 310V - - - @Tr 560V
— @Tp 310V - - - @Tp 560V

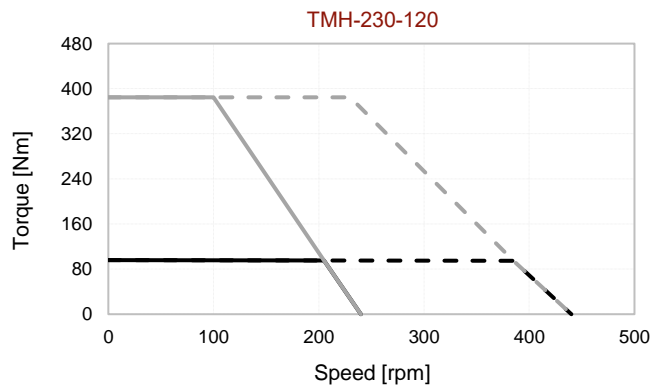
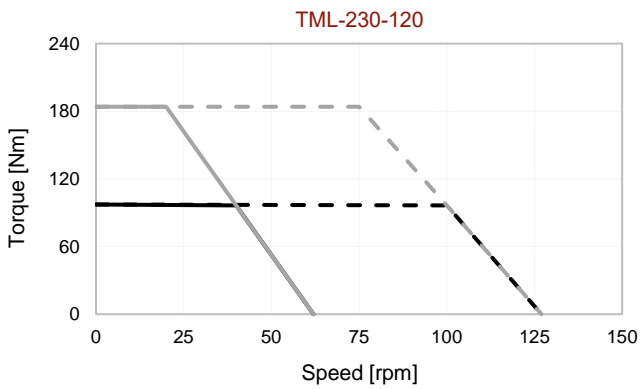
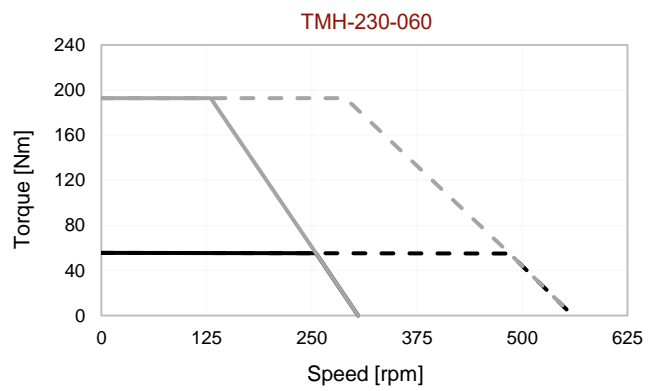
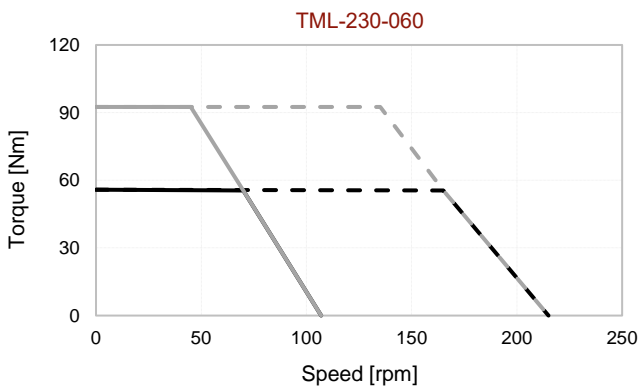
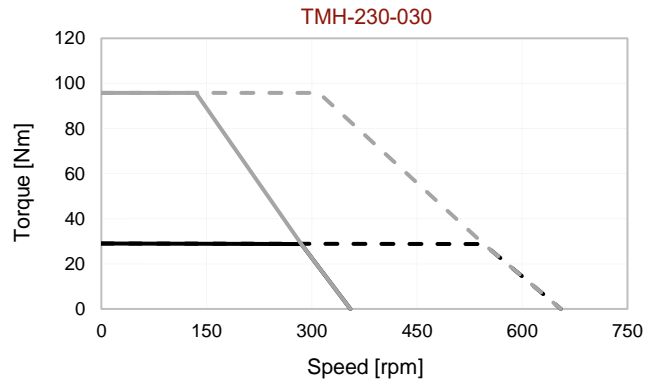
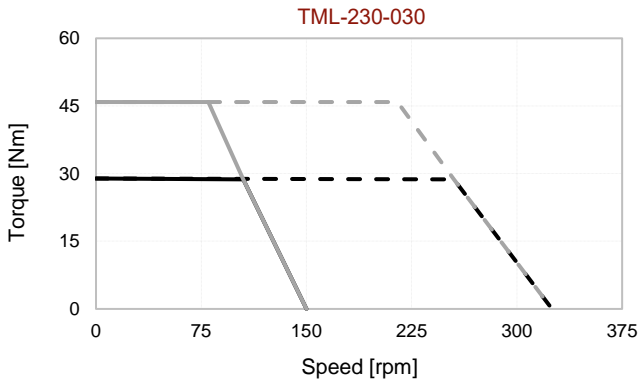

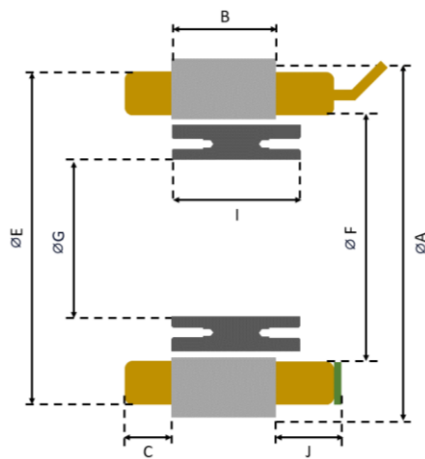
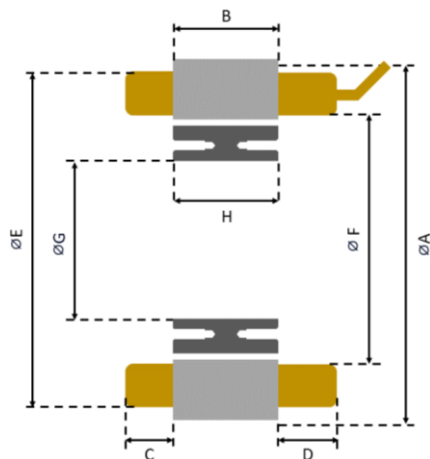

Hall Effect Sensor Option

Model	A (mm)	B (mm)	C (mm)	D (mm)	E (mm)	F (mm)	G (mm)	H (mm)	I (mm)	J (mm)
TM(L/H)-230-030	230	30	15	17	223	185	148	30.1	35.1	20
TM(L/H)-230-060	230	60	15	17	223	185	148	60.2	65.2	20
TM(L/H)-230-120	230	100	15	17	223	185	148	120.4	125.4	20

Notes:

MOTOR LEADS:

230-TML: #11 AWG Teflon® insulated, 500 mm (optional) length, 1-Red, 1-White, 1-Black.
 230-TMH: #14 AWG Teflon® insulated, 500 mm (optional) length, 1-Red, 1-White, 1-Black.

THERMISTOR LEADS:

#26 AWG Teflon® insulated, 500 mm (optional) length, 2-Brown or Blue.

SENSOR LEADS:

#23 AWG Teflon® insulated, 500 mm (optional) length, 1-Blue, 1-Green, 1-Brown, 1-White, 1-Yellow.

MOUNTING OPTION:

#Stator: 3x3 Keyway
 #Rotor: (16X on each side) M5 Bolt Hole (For details refer to MDS Motor mounting documents)

TRM-240 Technical Information

Motor Parameters		Symbols	Units	TML-240-035		TML-240-070		TML-240-140	
PERFORMANCE	DC Bus Voltage	V_{DC}	V	24	48	24	48	24	48
	Rated Torque	T_r	Nm	34.2		64.9		115.6	
	Peak Torque	T_p	Nm	54.3		112.1		218.6	
	Rated Speed	N_r	rpm	110	260	65	155	40	100
	No-Load Speed	$N_{no-load}$	rpm	155	320	95	195	60	125
	Torque Constant	K_t	Nm/A	1.71		2.8		4.36	
	Voltage Constant	K_v	V/rpm	0.147		0.241		0.373	
	Max. Cogging Torque	T_{cog}	%			<1			
	Torque Ripple	T_{ripple}	%			<1			
	ELECTRICAL	Number of Pole	$2p$	--			32		
Rated Current		I_r	A_{rms}	20		23.2		26.5	
Peak Current		I_p	A_{rms}	32		40.4		50.6	
Line Resistance		$R_{LL}@25^{\circ}C$	Ohm	0.22 ($\pm 20\%$)		0.22 ($\pm 20\%$)		0.23 ($\pm 20\%$)	
MECHANICAL & THERMAL	Line Inductance	$L_{LL}@60Hz$	mH	1.31 ($\pm 30\%$)		1.63 ($\pm 30\%$)		1.91 ($\pm 30\%$)	
	Stator Weight	W_s	kg	4.33		7.8		14.53	
	Rotor Weight	W_r	kg	2.35		4.73		9.49	
	Total Weight	W_{total}	kg	6.68		12.53		24.02	
	Mech. Time Constant	K_{mech}	ms	1.66		1.24		1.08	
	Thermal Resistance ⁽²⁾	R_{th}	$^{\circ}C/W$	0.433		0.310		0.225	
	Inertia	J	kg.m ²	0.01819		0.03647		0.07316	
	Motor Constant	K_m	Nm/ \sqrt{W}	1.72	1.12	3.09	2	5.25	3.32
	Rotor ID		mm			158			
	Stator OD		mm			240			

Motor Parameters		Symbols	Units	TMH-240-035		TMH-240-070		TMH-240-140	
PERFORMANCE	DC Bus Voltage	V_{DC}	V	310	560	310	560	310	560
	Rated Torque	T_r	Nm	34.8		64.5		115.8	
	Peak Torque	T_p	Nm	115.5		233.7		463.7	
	Rated Speed	N_r	rpm	280	535	260	490	185	350
	No-Load Speed	$N_{no-load}$	rpm	345	630	310	560	215	400
	Torque Constant	K_t	Nm/A	10.26		11.53		16.09	
	Voltage Constant	K_v	V/rpm	0.88		0.987		1.387	
	Max. Cogging Torque	T_{cog}	%			<1			
	Torque Ripple	T_{ripple}	%			<1			
	ELECTRICAL	Number of Pole	$2p$	--			32		
Rated Current		I_r	A_{rms}	3.4		5.6		7.2	
Peak Current		I_p	A_{rms}	12.15		22		31	
Line Resistance		$R_{LL}@25^{\circ}C$	Ohm	7.88 ($\pm 20\%$)		3.76 ($\pm 20\%$)		3.27 ($\pm 20\%$)	
MECHANICAL & THERMAL	Line Inductance	$L_{LL}@60Hz$	mH	47.2 ($\pm 30\%$)		27.7 ($\pm 30\%$)		26.3 ($\pm 30\%$)	
	Stator Weight	W_s	kg	4.26		7.77		14.56	
	Rotor Weight	W_r	kg	2.35		4.73		9.49	
	Total Weight	W_{total}	kg	6.61		12.50		24.05	
	Mech. Time Constant	K_{mech}	ms	1.66		1.26		1.12	
	Thermal Resistance ⁽²⁾	R_{th}	$^{\circ}C/W$	0.433		0.310		0.225	
	Inertia	J	kg.m ²	0.01819		0.03647		0.07316	
	Motor Constant	K_m	Nm/ \sqrt{W}	1.09	0.79	1.54	1.12	2.45	1.78
	Rotor ID		mm			158			
	Stator OD		mm			240			

1. All performance and electrical specifications are obtained at 25°C ambient and may change $\pm 10\%$. 2. Housed version of motor mounted to 350 mm sq. x 15 mm aluminum heat sink (maximum winding temperature is 120°C). 3. Higher torque and speed values as well as dimensions on request.

TM(L/H)-240 Torque-Speed Curves

Tr: Rated Torque
Tp: Peak Torque

— @Tr 24V - - - @Tr 48V
— @Tp 24V - - - @Tp 48V

— @Tr 310V - - - @Tr 560V
— @Tp 310V - - - @Tp 560V

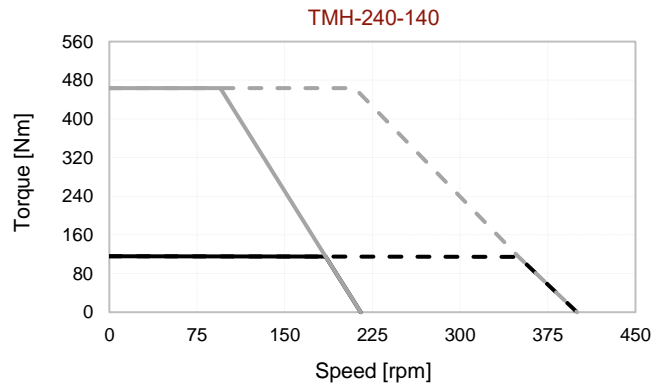
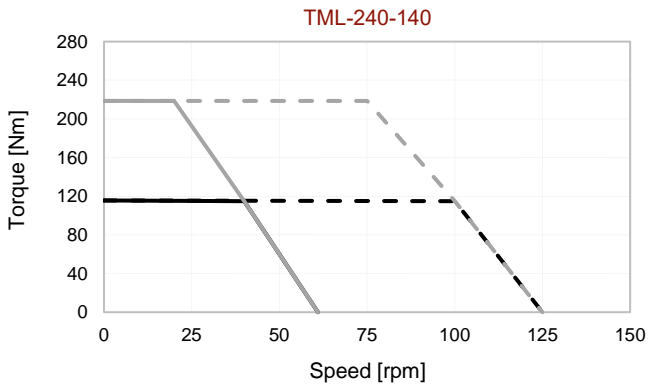
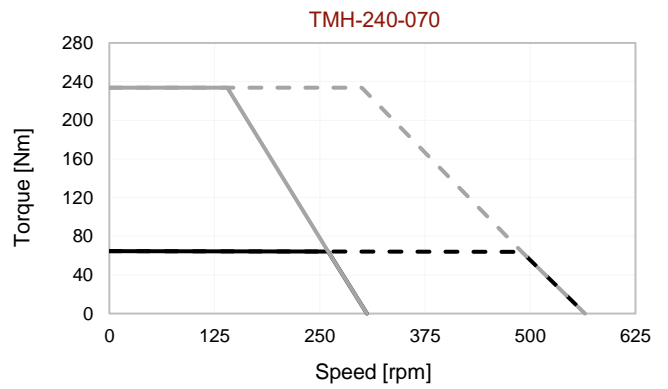
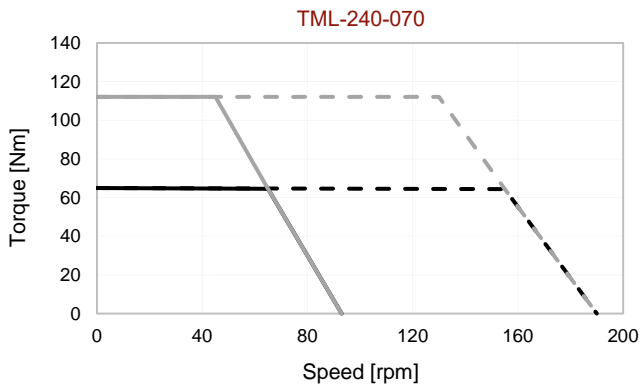
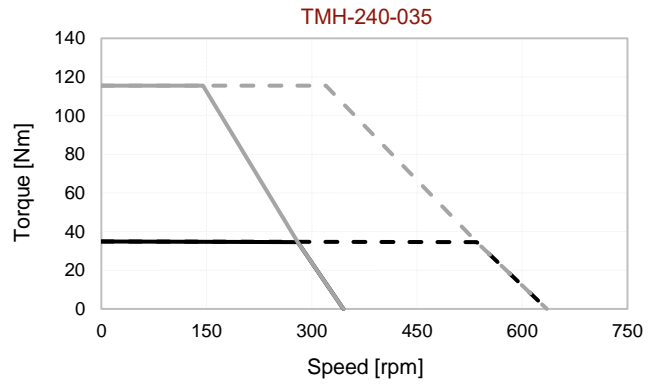
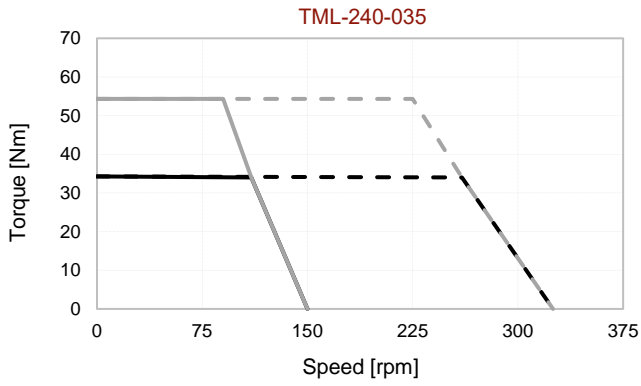

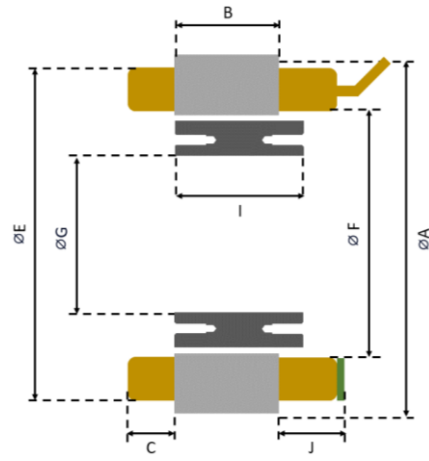
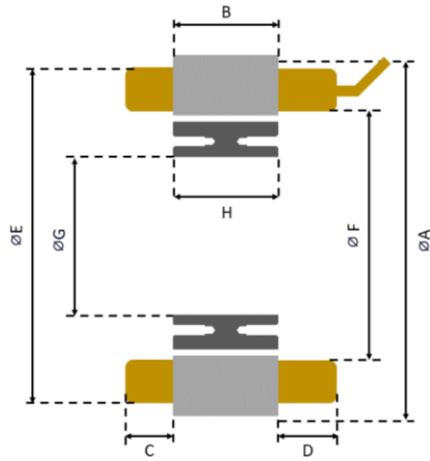

Hall Effect Sensor Option

Model	A (mm)	B (mm)	C (mm)	D (mm)	E (mm)	F (mm)	G (mm)	H (mm)	I (mm)	J (mm)
TM(L/H)-240-035	240	35	16	18	232	195.2	158	35.1	40.1	21
TM(L/H)-240-070	240	70	16	18	232	195.2	158	70.2	75.2	21
TM(L/H)-240-140	240	140	16	18	232	195.2	158	140.4	145.4	21

Notes:

MOTOR LEADS:

240-TML: #10 AWG Teflon® insulated, 500 mm (optional) length, 1-Red, 1-White, 1-Black.
 240-TMH: #13 AWG Teflon® insulated, 500 mm (optional) length, 1-Red, 1-White, 1-Black.

THERMISTOR LEADS:

#26 AWG Teflon® insulated, 500 mm (optional) length, 2-Brown or Blue.

SENSOR LEADS:

#23 AWG Teflon® insulated, 500 mm (optional) length, 1-Blue, 1-Green, 1-Brown, 1-White, 1-Yellow.

MOUNTING OPTION:

#Stator: 3x3 Keyway
 #Rotor: (16X on each side) M5 Bolt Hole (For details refer to MDS Motor mounting documents)

TRM-260 Technical Information

Motor Parameters		Symbols	Units	TML-260-035		TML-260-070		TML-260-140	
PERFORMANCE	DC Bus Voltage	V_{DC}	V	24	48	24	48	24	48
	Rated Torque	T_r	Nm	41.6		75		140.8	
	Peak Torque	T_p	Nm	69		135.7		266.9	
	Rated Speed	N_r	rpm	105	240	65	155	45	110
	No-Load Speed	$N_{no-load}$	rpm	150	300	95	190	65	135
	Torque Constant	K_t	Nm/A	1.83		2.84		4.07	
	Voltage Constant	K_v	V/rpm	0.156		0.243		0.348	
	Max. Cogging Torque	T_{cog}	%			<1			
	Torque Ripple	T_{ripple}	%			<1			
	ELECTRICAL	Number of Pole	$2p$	--			40		
Rated Current		I_r	A_{rms}	22.8		26.4		34.6	
Peak Current		I_p	A_{rms}	38		48		66	
Line Resistance		$R_{LL}@25^{\circ}C$	Ohm	0.21 ($\pm 20\%$)		0.19 ($\pm 20\%$)		0.17 ($\pm 20\%$)	
Line Inductance		$L_{LL}@60Hz$	mH	1.04 ($\pm 30\%$)		1.18 ($\pm 30\%$)		1.15 ($\pm 30\%$)	
MECHANICAL & THERMAL	Stator Weight	W_s	kg	4.75		8.41		15.76	
	Rotor Weight	W_r	kg	2.60		5.23		10.47	
	Total Weight	W_{total}	kg	7.35		13.64		26.23	
	Mech. Time Constant	K_{mech}	ms	1.86		1.46		1.23	
	Thermal Resistance ⁽²⁾	R_{th}	$^{\circ}C/W$	0.358		0.276		0.200	
	Inertia	J	kg.m ²	0.02473		0.04983		0.10003	
	Motor Constant	K_m	Nm/ \sqrt{W}	1.95	1.29	3.32	2.15	5.47	3.5
	Rotor ID		mm			178			
	Stator OD		mm			260			

Motor Parameters		Symbols	Units	TMH-260-035		TMH-260-070		TMH-260-140	
PERFORMANCE	DC Bus Voltage	V_{DC}	V	310	560	310	560	310	560
	Rated Torque	T_r	Nm	40.5		74.1		141.1	
	Peak Torque	T_p	Nm	142.5		282.8		567.8	
	Rated Speed	N_r	rpm	260	500	230	435	165	315
	No-Load Speed	$N_{no-load}$	rpm	325	590	275	500	195	360
	Torque Constant	K_t	Nm/A	10.97		13		17.87	
	Voltage Constant	K_v	V/rpm	0.938		1.112		1.529	
	Max. Cogging Torque	T_{cog}	%			<1			
	Torque Ripple	T_{ripple}	%			<1			
	ELECTRICAL	Number of Pole	$2p$	--			40		
Rated Current		I_r	A_{rms}	3.7		5.7		7.9	
Peak Current		I_p	A_{rms}	14		23.4		34.2	
Line Resistance		$R_{LL}@25^{\circ}C$	Ohm	7.72 ($\pm 20\%$)		4.1 ($\pm 20\%$)		3.16 ($\pm 20\%$)	
Line Inductance		$L_{LL}@60Hz$	mH	37.5 ($\pm 30\%$)		24.5 ($\pm 30\%$)		22.3 ($\pm 30\%$)	
MECHANICAL & THERMAL	Stator Weight	W_s	kg	4.66		8.41		15.79	
	Rotor Weight	W_r	kg	2.60		5.23		10.47	
	Total Weight	W_{total}	kg	7.26		13.64		26.26	
	Mech. Time Constant	K_{mech}	ms	1.94		1.48		1.21	
	Thermal Resistance ⁽²⁾	R_{th}	$^{\circ}C/W$	0.358		0.276		0.200	
	Inertia	J	kg.m ²	0.02473		0.04983		0.10003	
	Motor Constant	K_m	Nm/ \sqrt{W}	1.22	0.88	1.75	1.28	2.86	2.07
	Rotor ID		mm			178			
	Stator OD		mm			260			

1. All performance and electrical specifications are obtained at 25°C ambient and may change $\pm 10\%$. 2. Housed version of motor mounted to 390 mm sq. x 15 mm aluminum heat sink (maximum winding temperature is 120°C). 3. Higher torque and speed values as well as dimensions on request.

TM(L/H)-260 Torque-Speed Curves

Tr: Rated Torque
Tp: Peak Torque

— @Tr 24V - - - @Tr 48V
— @Tp 24V - - - @Tp 48V

— @Tr 310V - - - @Tr 560V
— @Tp 310V - - - @Tp 560V

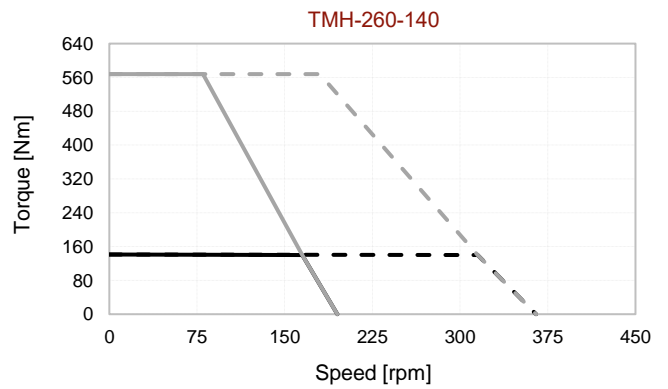
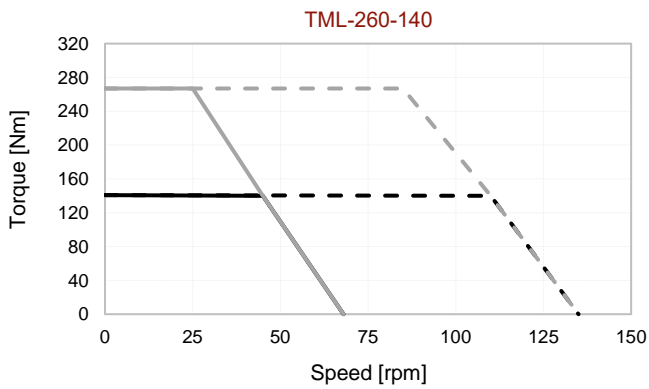
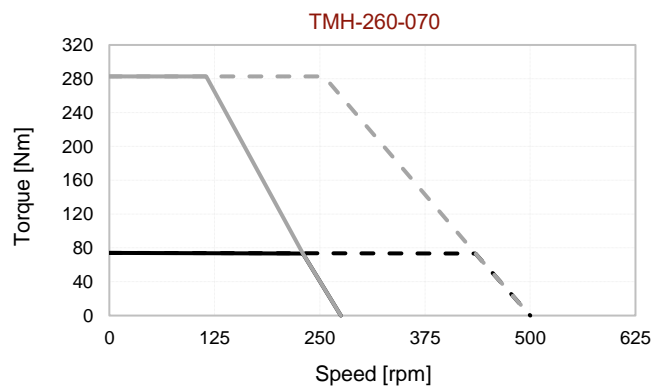
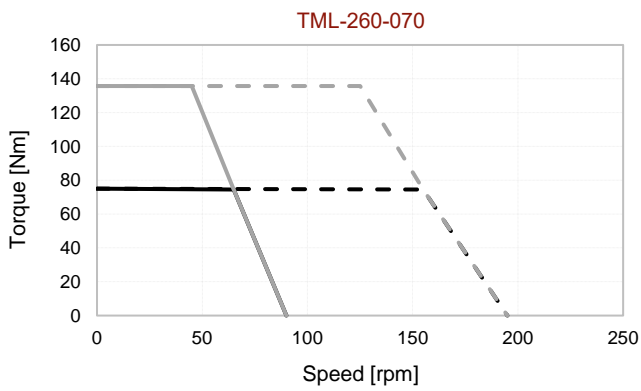
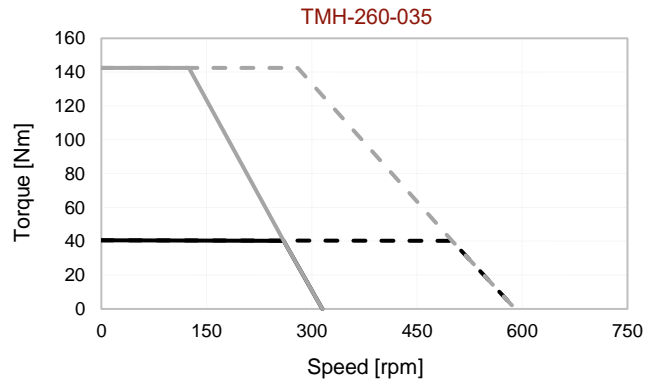
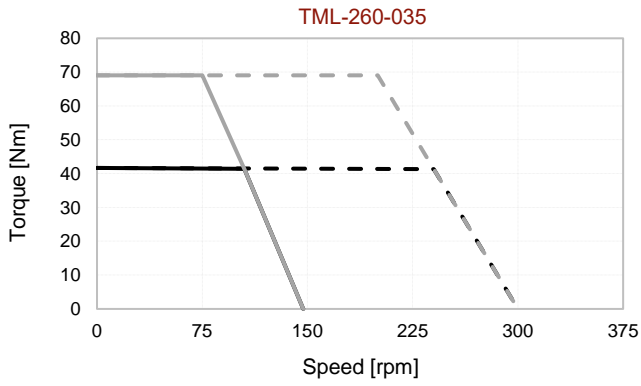

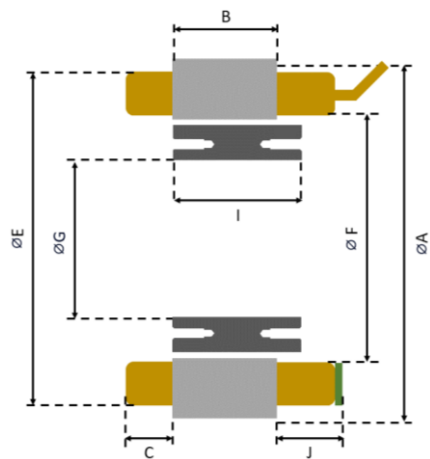
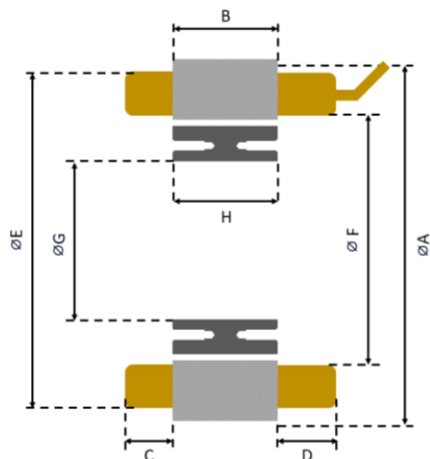

Hall Effect Sensor Option

Model	A (mm)	B (mm)	C (mm)	D (mm)	E (mm)	F (mm)	G (mm)	H (mm)	I (mm)	J (mm)
TM(L/H)-260-035	260	35	16	18	253	215.5	178	35.1	40.1	21
TM(L/H)-260-070	260	70	16	18	253	215.5	178	70.2	75.2	21
TM(L/H)-260-140	260	140	16	18	253	215.5	178	140.4	145.4	21

Notes:

MOTOR LEADS:

260-TML: #9 AWG Teflon® insulated, 500 mm (optional) length, 1-Red, 1-White, 1-Black.
 260-TMH: #13 AWG Teflon® insulated, 500 mm (optional) length, 1-Red, 1-White, 1-Black.

THERMISTOR LEADS:

#26 AWG Teflon® insulated, 500 mm (optional) length, 2-Brown or Blue.

SENSOR LEADS:

#23 AWG Teflon® insulated, 500 mm (optional) length, 1-Blue, 1-Green, 1-Brown, 1-White, 1-Yellow.

MOUNTING OPTION:

#Stator: 3x3 Keyway
 #Rotor: (20X on each side) M5 Bolt Hole (For details refer to MDS Motor mounting documents)

Motor Parameters		Symbols	Units	TML-290-035		TML-290-070		TML-290-140	
PERFORMANCE	DC Bus Voltage	V_{DC}	V	24	48	24	48	24	48
	Rated Torque	T_r	Nm	55		104.2		190.3	
	Peak Torque	T_p	Nm	91.2		180.2		360.6	
	Rated Speed	N_r	rpm	105	240	70	160	40	95
	No-Load Speed	$N_{no-load}$	rpm	145	295	95	195	55	115
	Torque Constant	K_t	Nm/A	1.86		2.79		4.65	
	Voltage Constant	K_v	V/rpm	0.16		0.239		0.399	
	Max. Cogging Torque	T_{cog}	%			<1			
	Torque Ripple	T_{ripple}	%			<1			
	Number of Pole	$2p$	--			40			
ELECTRICAL	Rated Current	I_r	A_{rms}	29.6		37.4		40.9	
	Peak Current	I_p	A_{rms}	49.4		65		78	
	Line Resistance	$R_{LL}@25^{\circ}C$	Ohm	0.15 ($\pm 20\%$)		0.12 ($\pm 20\%$)		0.14 ($\pm 20\%$)	
	Line Inductance	$L_{LL}@60Hz$	mH	0.85 ($\pm 30\%$)		0.88 ($\pm 30\%$)		1.18 ($\pm 30\%$)	
	MECHANICAL & THERMAL	Stator Weight	W_s	kg	5.7		10.1		18.9
Rotor Weight		W_r	kg	3.48		7.01		14.05	
Total Weight		W_{total}	kg	9.18		17.02		32.95	
Mech. Time Constant		K_{mech}	ms	2.25		1.62		1.35	
Thermal Resistance ⁽²⁾		R_{th}	$^{\circ}C/W$	0.304		0.217		0.164	
Inertia		J	kg.m ²	0.04239		0.08519		0.17078	
Motor Constant		K_m	Nm/ \sqrt{W}	2.24	1.48	3.77	2.49	6.74	4.37
Rotor ID			mm			200			
Stator OD			mm			290			

Motor Parameters		Symbols	Units	TMH-290-035		TMH-290-070		TMH-290-140	
PERFORMANCE	DC Bus Voltage	V_{DC}	V	310	560	310	560	310	560
	Rated Torque	T_r	Nm	54.6		104.6		190.4	
	Peak Torque	T_p	Nm	190.6		379.1		758.1	
	Rated Speed	N_r	rpm	260	495	230	430	160	305
	No-Load Speed	$N_{no-load}$	rpm	320	580	270	495	190	345
	Torque Constant	K_t	Nm/A	11.15		13		18.49	
	Voltage Constant	K_v	V/rpm	0.956		1.116		1.594	
	Max. Cogging Torque	T_{cog}	%			<1			
	Torque Ripple	T_{ripple}	%			<1			
	Number of Pole	$2p$	--			40			
ELECTRICAL	Rated Current	I_r	A_{rms}	4.9		8.05		10.3	
	Peak Current	I_p	A_{rms}	18.5		31.5		44.1	
	Line Resistance	$R_{LL}@25^{\circ}C$	Ohm	5.36 ($\pm 20\%$)		2.62 ($\pm 20\%$)		2.24 ($\pm 20\%$)	
	Line Inductance	$L_{LL}@60Hz$	mH	30.7 ($\pm 30\%$)		19.3 ($\pm 30\%$)		18.9 ($\pm 30\%$)	
	MECHANICAL & THERMAL	Stator Weight	W_s	kg	5.67		10		18.9
Rotor Weight		W_r	kg	3.48		7.01		14.05	
Total Weight		W_{total}	kg	9.15		17.01		32.95	
Mech. Time Constant		K_{mech}	ms	2.23		1.61		1.36	
Thermal Resistance ⁽²⁾		R_{th}	$^{\circ}C/W$	0.304		0.217		0.164	
Inertia		J	kg.m ²	0.04239		0.08519		0.17078	
Motor Constant		K_m	Nm/ \sqrt{W}	1.42	1.03	2.08	1.52	3.37	2.44
Rotor ID			mm			200			
Stator OD			mm			290			

1. All performance and electrical specifications are obtained at 25°C ambient and may change $\pm 10\%$. 2. Housed version of motor mounted to 430 mm sq. x 20 mm aluminum heat sink (maximum winding temperature is 120°C). 3. Higher torque and speed values as well as dimensions on request.

TM(L/H)-290 Torque-Speed Curves

Tr: Rated Torque
Tp: Peak Torque

— @Tr 24V - - - @Tr 48V
— @Tp 24V - - - @Tp 48V

— @Tr 310V - - - @Tr 560V
— @Tp 310V - - - @Tp 560V

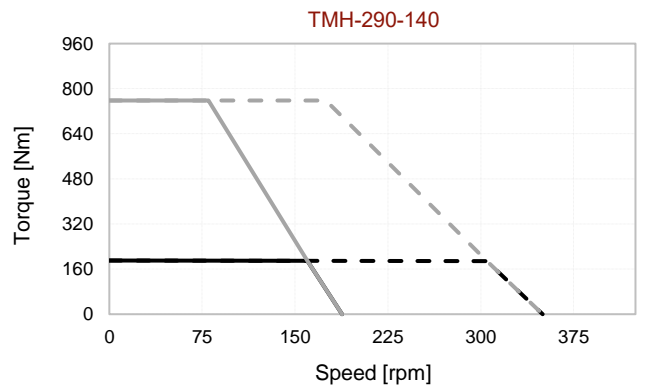
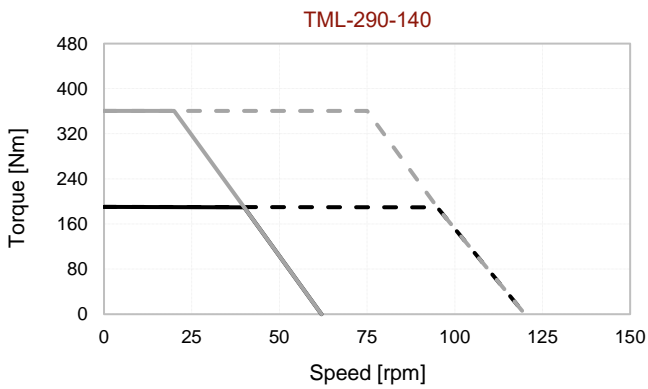
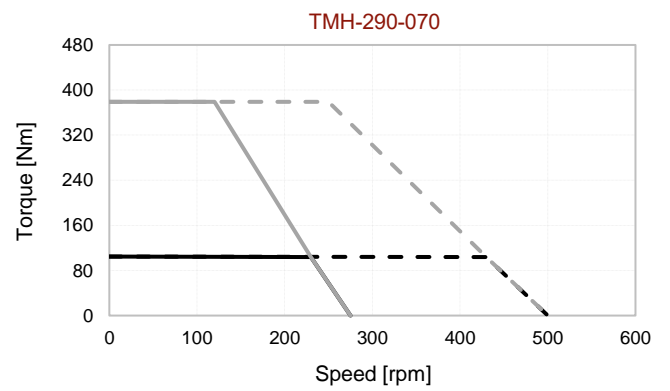
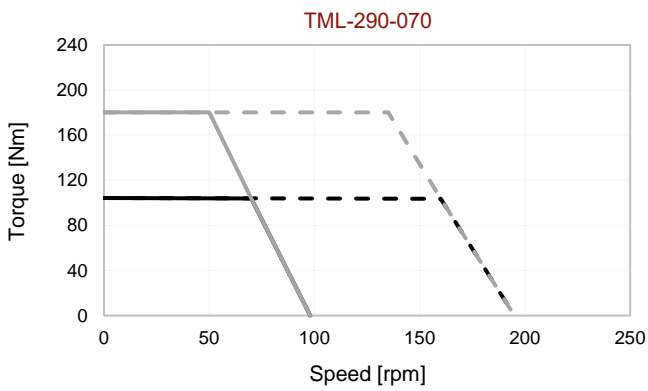
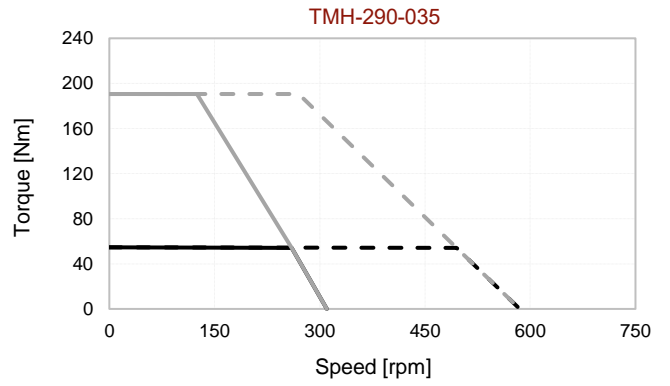
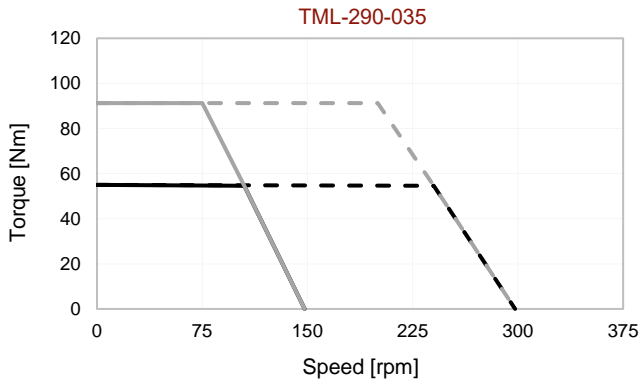

TM(L/H)-290 Outline Drawing

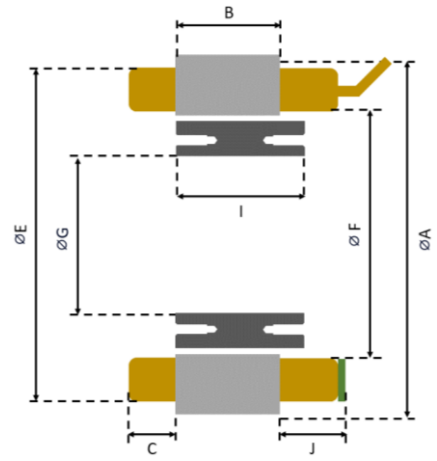
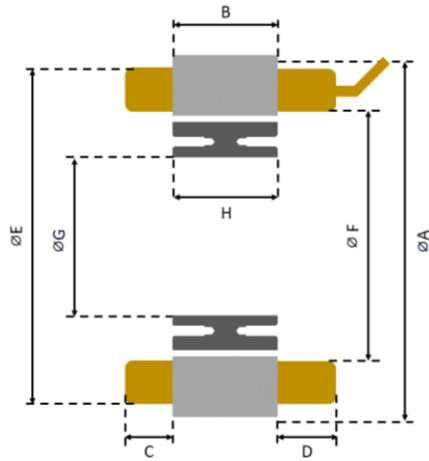

Hall Effect Sensor Option

Model	A (mm)	B (mm)	C (mm)	D (mm)	E (mm)	F (mm)	G (mm)	H (mm)	I (mm)	J (mm)
TM(L/H)-290-035	290	35	16	18	282	244.8	200	35.1	40.1	21
TM(L/H)-290-070	290	70	16	18	282	244.8	200	70.2	75.2	21
TM(L/H)-290-140	290	140	16	18	282	244.8	200	140.4	145.4	21

Notes:

MOTOR LEADS:

290-TML: #8 AWG Teflon® insulated, 500 mm (optional) length, 1-Red, 1-White, 1-Black.
 290-TMH: #12 AWG Teflon® insulated, 500 mm (optional) length, 1-Red, 1-White, 1-Black.

THERMISTOR LEADS:

#26 AWG Teflon® insulated, 500 mm (optional) length, 2-Brown or Blue.

SENSOR LEADS:

#23 AWG Teflon® insulated, 500 mm (optional) length, 1-Blue, 1-Green, 1-Brown, 1-White, 1-Yellow.

MOUNTING OPTION:

#Stator: 3x3 Keyway

#Rotor: (20X on each side) M5 Bolt Hole (For details refer to MDS Motor mounting documents)

Motor Parameters		Symbols	Units	TML-310-035		TML-310-070		TML-310-140	
PERFORMANCE	DC Bus Voltage	V_{DC}	V	24	48	24	48	24	48
	Rated Torque	T_r	Nm	68.4		125.8		219.9	
	Peak Torque	T_p	Nm	109		218		437.2	
	Rated Speed	N_r	rpm	95	210	65	150	40	95
	No-Load Speed	$N_{no-load}$	rpm	130	270	90	190	55	115
	Torque Constant	K_t	Nm/A	2.03		2.9		4.64	
	Voltage Constant	K_v	V/rpm	0.174		0.249		0.398	
	Max. Cogging Torque	T_{cog}	%			<1			
	Torque Ripple	T_{ripple}	%			<1			
	ELECTRICAL	Number of Pole	$2p$	--			48		
Rated Current		I_r	A_{rms}	33.7		43.4		47.4	
Peak Current		I_p	A_{rms}	54		75.6		94.8	
Line Resistance		$R_{LL}@25^{\circ}C$	Ohm	0.15 ($\pm 20\%$)		0.11 ($\pm 20\%$)		0.12 ($\pm 20\%$)	
Line Inductance		$L_{LL}@60Hz$	mH	0.74 ($\pm 30\%$)		0.7 ($\pm 30\%$)		0.85 ($\pm 30\%$)	
MECHANICAL & THERMAL	Stator Weight	W_s	kg	5.80		10.40		19.76	
	Rotor Weight	W_r	kg	3.76		7.65		15.30	
	Total Weight	W_{total}	kg	9.56		18.05		35.06	
	Mech. Time Constant	K_{mech}	ms	2.34		1.79		1.45	
	Thermal Resistance ⁽²⁾	R_{th}	$^{\circ}C/W$	0.243		0.182		0.141	
	Inertia	J	kg.m ²	0.05439		0.11055		0.22116	
	Motor Constant	K_m	Nm/ \sqrt{W}	2.62	1.76	4.3	2.83	7.25	4.70
	Rotor ID		mm			220			
	Stator OD		mm			310			

Motor Parameters		Symbols	Units	TMH-310-035		TMH-310-070		TMH-310-140	
PERFORMANCE	DC Bus Voltage	V_{DC}	V	310	560	310	560	310	560
	Rated Torque	T_r	Nm	68.2		126.2		219.2	
	Peak Torque	T_p	Nm	226.8		455.5		907.3	
	Rated Speed	N_r	rpm	230	440	200	380	140	270
	No-Load Speed	$N_{no-load}$	rpm	290	530	245	445	165	305
	Torque Constant	K_t	Nm/A	12.18		14.5		20.88	
	Voltage Constant	K_v	V/rpm	1.044		1.243		1.789	
	Max. Cogging Torque	T_{cog}	%			<1			
	Torque Ripple	T_{ripple}	%			<1			
	ELECTRICAL	Number of Pole	$2p$	--			48		
Rated Current		I_r	A_{rms}	5.6		8.7		10.5	
Peak Current		I_p	A_{rms}	20.2		34.2		47.2	
Line Resistance		$R_{LL}@25^{\circ}C$	Ohm	5.2 ($\pm 20\%$)		2.8 ($\pm 20\%$)		2.4 ($\pm 20\%$)	
Line Inductance		$L_{LL}@60Hz$	mH	26.8 ($\pm 30\%$)		17.5 ($\pm 30\%$)		17.4 ($\pm 30\%$)	
MECHANICAL & THERMAL	Stator Weight	W_s	kg	5.81		10.41		19.78	
	Rotor Weight	W_r	kg	3.76		7.65		15.30	
	Total Weight	W_{total}	kg	9.57		18.05		35.08	
	Mech. Time Constant	K_{mech}	ms	2.33		1.79		1.49	
	Thermal Resistance ⁽²⁾	R_{th}	$^{\circ}C/W$	0.243		0.182		0.141	
	Inertia	J	kg.m ²	0.05439		0.11055		0.22116	
	Motor Constant	K_m	Nm/ \sqrt{W}	1.68	1.22	2.45	1.78	3.87	2.78
	Rotor ID		mm			220			
	Stator OD		mm			310			

1. All performance and electrical specifications are obtained at 25°C ambient and may change $\pm 10\%$. 2. Housed version of motor mounted to 490 mm sq. x 20 mm aluminum heat sink (maximum winding temperature is 120°C). 3. Higher torque and speed values as well as dimensions on request.

TM(L/H)-310 Torque-Speed Curves

Tr: Rated Torque
Tp: Peak Torque

— @Tr 24V - - - @Tr 48V
— @Tp 24V - - - @Tp 48V

— @Tr 310V - - - @Tr 560V
— @Tp 310V - - - @Tp 560V

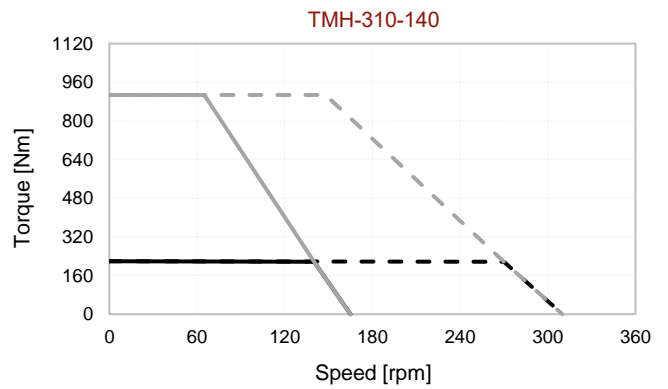
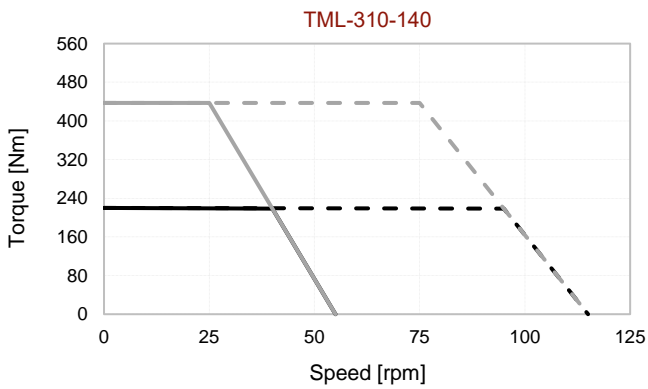
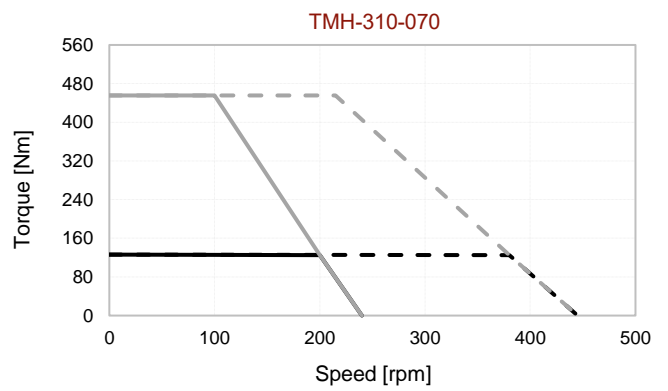
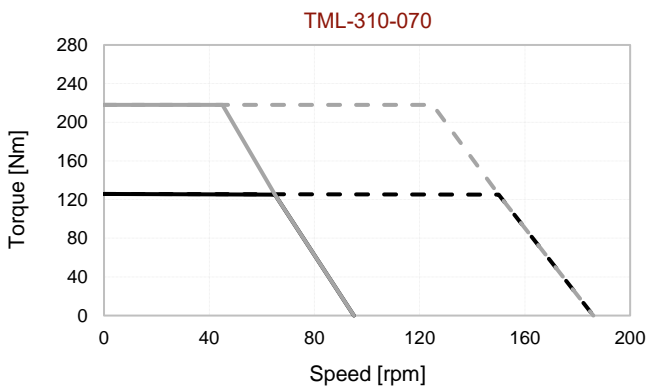
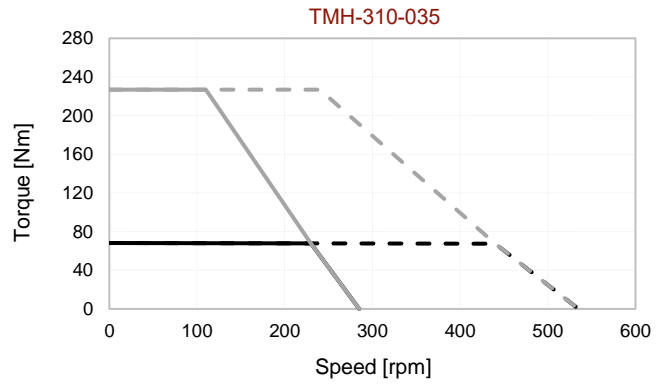
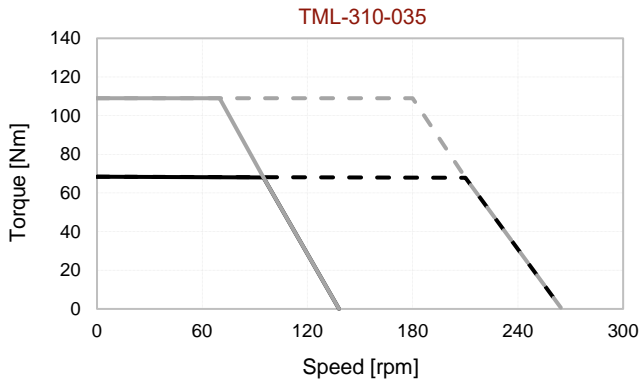

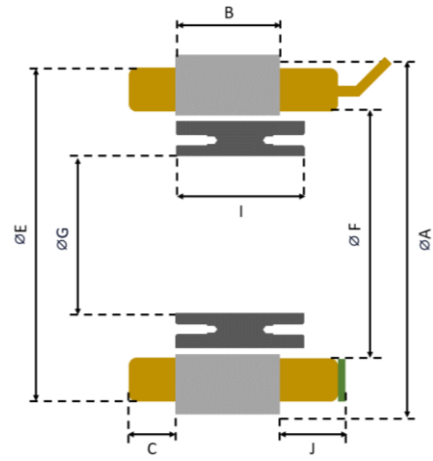
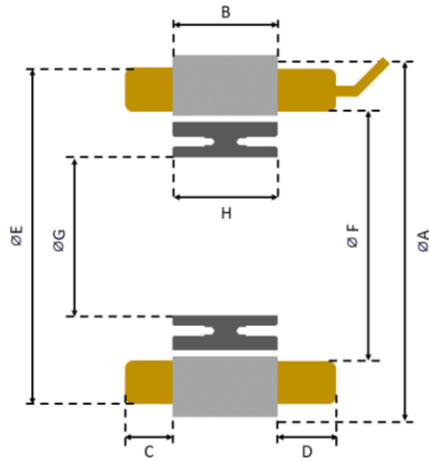

Hall Effect Sensor Option

Model	A (mm)	B (mm)	C (mm)	D (mm)	E (mm)	F (mm)	G (mm)	H (mm)	I (mm)	J (mm)
TM(L/H)-310-035	310	35	16	18	302	263.7	220	35.1	40.1	21
TM(L/H)-310-070	310	70	16	18	302	263.7	220	70.2	75.2	21
TM(L/H)-310-140	310	140	16	18	302	263.7	220	140.4	145.4	21

Notes:

MOTOR LEADS:

310-TML: #7 AWG Teflon® insulated, 500 mm (optional) length, 1-Red, 1-White, 1-Black.
 310-TMH: #11 AWG Teflon® insulated, 500 mm (optional) length, 1-Red, 1-White, 1-Black.

THERMISTOR LEADS:

#26 AWG Teflon® insulated, 500 mm (optional) length, 2-Brown or Blue.

SENSOR LEADS:

#23 AWG Teflon® insulated, 500 mm (optional) length, 1-Blue, 1-Green, 1-Brown, 1-White, 1-Yellow.

MOUNTING OPTION:

#Stator: 3x3 Keyway
 #Rotor: (24X on each side) M5 Bolt Hole (For details refer to MDS Motor mounting documents)

TRM-330 Technical Information

Motor Parameters		Symbols	Units	TML-330-035		TML-330-070		TML-330-140	
PERFORMANCE	DC Bus Voltage	V_{DC}	V	24	48	24	48	24	48
	Rated Torque	T_r	Nm	78.8		144.2		250.3	
	Peak Torque	T_p	Nm	124.5		249.7		498.1	
	Rated Speed	N_r	rpm	100	230	60	140	35	85
	No-Load Speed	$N_{no-load}$	rpm	140	280	80	165	50	105
	Torque Constant	K_t	Nm/A	1.97		3.26		5.21	
	Voltage Constant	K_v	V/rpm	0.167		0.279		0.446	
	Max. Cogging Torque	T_{cog}	%			<1			
	Torque Ripple	T_{ripple}	%			<1			
	ELECTRICAL	Number of Pole	$2p$	--			48		
Rated Current		I_r	A_{rms}	40		44.2		48	
Peak Current		I_p	A_{rms}	64		77		96	
Line Resistance		$R_{LL}@25^{\circ}C$	Ohm	0.1 ($\pm 20\%$)		0.11 ($\pm 20\%$)		0.12 ($\pm 20\%$)	
Line Inductance		$L_{LL}@60Hz$	mH	0.54 ($\pm 30\%$)		0.7 ($\pm 30\%$)		0.85 ($\pm 30\%$)	
MECHANICAL & THERMAL	Stator Weight	W_s	kg	6.5		11.62		21.7	
	Rotor Weight	W_r	kg	4.12		8.28		16.61	
	Total Weight	W_{total}	kg	10.62		19.90		38.31	
	Mech. Time Constant	K_{mech}	ms	2.28		1.75		1.47	
	Thermal Resistance ⁽²⁾	R_{th}	$^{\circ}C/W$	0.242		0.180		0.138	
	Inertia	J	kg.m ²	0.06988		0.14044		0.28155	
	Motor Constant	K_m	Nm/ \sqrt{W}	2.74	1.81	4.79	3.14	8.26	5.3
	Rotor ID		mm			240			
	Stator OD		mm			330			

Motor Parameters		Symbols	Units	TMH-330-035		TMH-330-070		TMH-330-140	
PERFORMANCE	DC Bus Voltage	V_{DC}	V	310	560	310	560	310	560
	Rated Torque	T_r	Nm	78.6		143.5		250.5	
	Peak Torque	T_p	Nm	264.9		525.7		1048.9	
	Rated Speed	N_r	rpm	250	470	210	395	145	275
	No-Load Speed	$N_{no-load}$	rpm	300	550	245	450	170	310
	Torque Constant	K_t	Nm/A	11.74		14.35		20.88	
	Voltage Constant	K_v	V/rpm	1.003		1.225		1.783	
	Max. Cogging Torque	T_{cog}	%			<1			
	Torque Ripple	T_{ripple}	%			<1			
	ELECTRICAL	Number of Pole	$2p$	--			48		
Rated Current		I_r	A_{rms}	6.7		10		12	
Peak Current		I_p	A_{rms}	24.3		39.4		54	
Line Resistance		$R_{LL}@25^{\circ}C$	Ohm	3.62 ($\pm 20\%$)		2.07 ($\pm 20\%$)		1.84 ($\pm 20\%$)	
Line Inductance		$L_{LL}@60Hz$	mH	19.1 ($\pm 30\%$)		13.42 ($\pm 30\%$)		13.8 ($\pm 30\%$)	
MECHANICAL & THERMAL	Stator Weight	W_s	kg	6.56		11.6		21.8	
	Rotor Weight	W_r	kg	4.12		8.28		16.61	
	Total Weight	W_{total}	kg	10.68		19.88		37.41	
	Mech. Time Constant	K_{mech}	ms	2.25		1.73		1.46	
	Thermal Resistance ⁽²⁾	R_{th}	$^{\circ}C/W$	0.242		0.180		0.138	
	Inertia	J	kg.m ²	0.06988		0.14044		0.28155	
	Motor Constant	K_m	Nm/ \sqrt{W}	1.73	1.26	2.55	1.86	4.06	2.95
	Rotor ID		mm			240			
	Stator OD		mm			330			

1. All performance and electrical specifications are obtained at 25°C ambient and may change $\pm 10\%$. 2. Housed version of motor mounted to 490 mm sq. x 20 mm aluminum heat sink (maximum winding temperature is 120°C). 3. Higher torque and speed values as well as dimensions on request.

TM(L/H)-330 Torque-Speed Curves

Tr: Rated Torque
Tp: Peak Torque

— @Tr 24V - - - @Tr 48V
— @Tp 24V - - - @Tp 48V

— @Tr 310V - - - @Tr 560V
— @Tp 310V - - - @Tp 560V

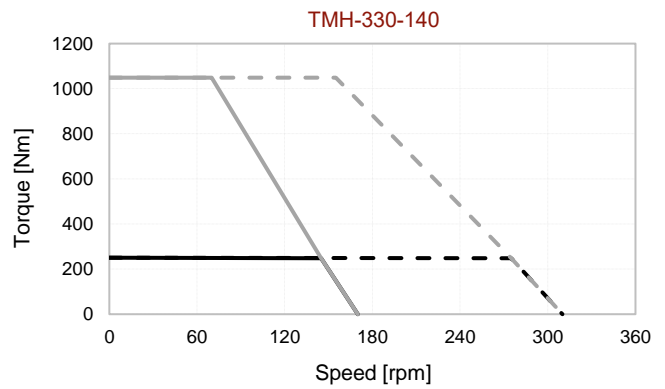
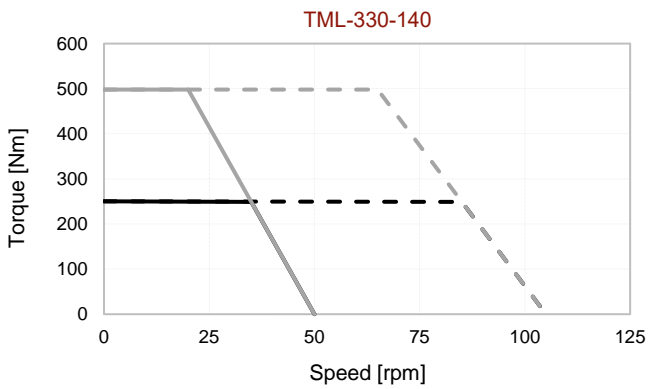
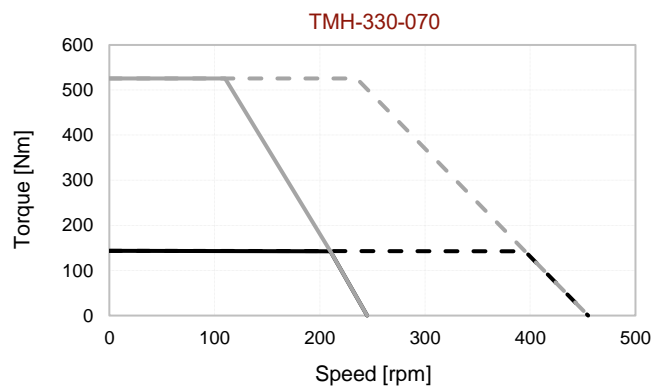
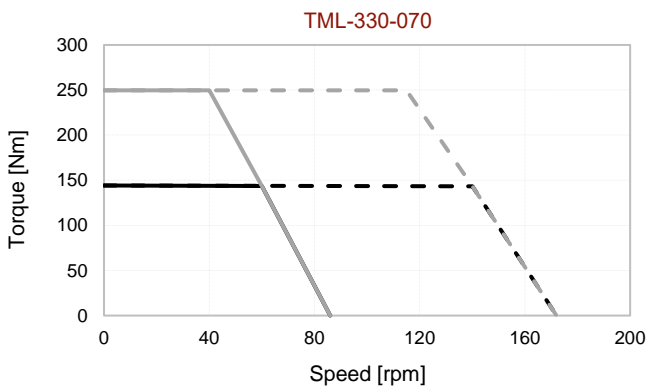
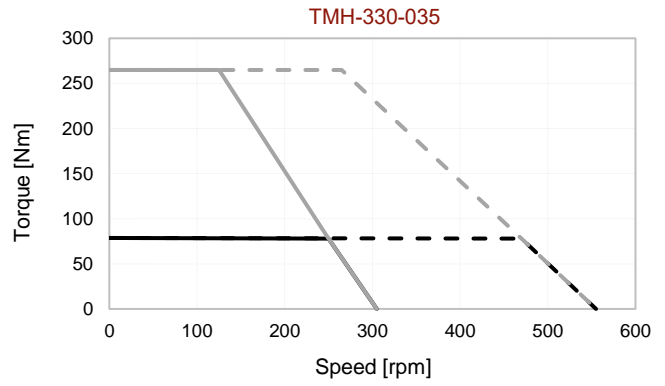
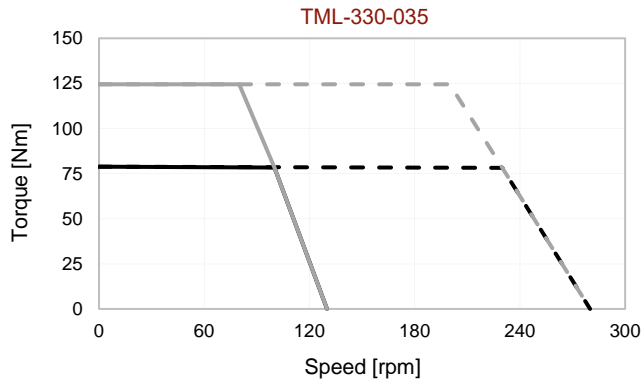

TM(L/H)-330 Outline Drawing

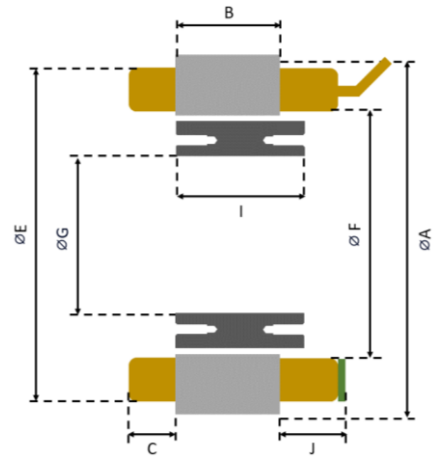
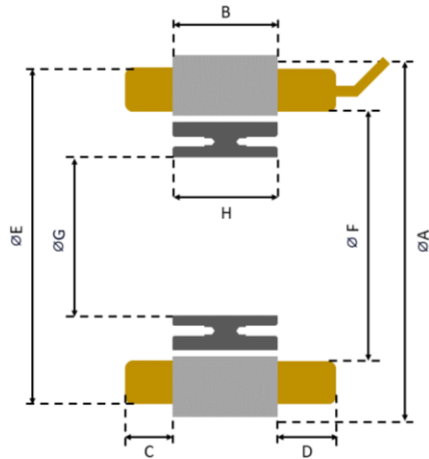

Hall Effect Sensor Option

Model	A (mm)	B (mm)	C (mm)	D (mm)	E (mm)	F (mm)	G (mm)	H (mm)	I (mm)	J (mm)
TM(L/H)-330-035	330	35	16	18	322	284	240	35.1	40.1	21
TM(L/H)-330-070	330	70	16	18	322	284	240	70.2	75.2	21
TM(L/H)-330-140	330	140	16	18	322	284	240	140.4	145.4	21

Notes:

MOTOR LEADS:

330-TML: #7 AWG Teflon® insulated, 500 mm (optional) length, 1-Red, 1-White, 1-Black.
 330-TMH: #11 AWG Teflon® insulated, 500 mm (optional) length, 1-Red, 1-White, 1-Black.

THERMISTOR LEADS:

#26 AWG Teflon® insulated, 500 mm (optional) length, 2-Brown or Blue.

SENSOR LEADS:

#23 AWG Teflon® insulated, 500 mm (optional) length, 1-Blue, 1-Green, 1-Brown, 1-White, 1-Yellow.

MOUNTING OPTION:

#Stator: 3x3 Keyway

#Rotor: (24X on each side) M5 Bolt Hole (For details refer to MDS Motor mounting documents)

Motor Parameters		Symbols	Units	TML-360-035		TML-360-070		TML-360-140	
PERFORMANCE	DC Bus Voltage	V_{DC}	V	24	48	24	48	24	48
	Rated Torque	T_r	Nm	94.3		171.8		301.5	
	Peak Torque	T_p	Nm	150.5		297.8		600.5	
	Rated Speed	N_r	rpm	85	200	55	125	35	85
	No-Load Speed	$N_{no-load}$	rpm	125	250	75	155	50	100
	Torque Constant	K_t	Nm/A	2.2		3.53		5.29	
	Voltage Constant	K_v	V/rpm	0.185		0.302		0.452	
	Max. Cogging Torque	T_{cog}	%			<1			
	Torque Ripple	T_{ripple}	%			<1			
	ELECTRICAL	Number of Pole	$2p$	--			64		
Rated Current		I_r	A_{rms}	42.8		48.7		57	
Peak Current		I_p	A_{rms}	68.6		84.8		114	
Line Resistance		$R_{LL}@25^{\circ}C$	Ohm	0.11 ($\pm 20\%$)		0.1 ($\pm 20\%$)		0.09 ($\pm 20\%$)	
Line Inductance		$L_{LL}@60Hz$	mH	0.44 ($\pm 30\%$)		0.56 ($\pm 30\%$)		0.59 ($\pm 30\%$)	
MECHANICAL & THERMAL	Stator Weight	W_s	kg	7.22		12.77		23.8	
	Rotor Weight	W_r	kg	4.40		8.81		17.64	
	Total Weight	W_{total}	kg	11.62		21.58		41.44	
	Mech. Time Constant	K_{mech}	ms	2.57		1.88		1.51	
	Thermal Resistance ⁽²⁾	R_{th}	$^{\circ}C/W$	0.189		0.146		0.115	
	Inertia	J	kg.m ²	0.09193		0.18450		0.36966	
	Motor Constant	K_m	Nm/ \sqrt{W}	3.26	2.12	5.46	3.62	9.07	5.82
	Rotor ID		mm			270			
	Stator OD		mm			360			

Motor Parameters		Symbols	Units	TMH-360-035		TMH-360-070		TMH-360-140	
PERFORMANCE	DC Bus Voltage	V_{DC}	V	310	560	310	560	310	560
	Rated Torque	T_r	Nm	93.7		172.9		299.6	
	Peak Torque	T_p	Nm	316.6		632.8		1262.1	
	Rated Speed	N_r	rpm	230	440	185	350	140	270
	No-Load Speed	$N_{no-load}$	rpm	290	525	225	405	165	305
	Torque Constant	K_t	Nm/A	12.34		15.9		21.1	
	Voltage Constant	K_v	V/rpm	1.055		1.356		1.809	
	Max. Cogging Torque	T_{cog}	%			<1			
	Torque Ripple	T_{ripple}	%			<1			
	ELECTRICAL	Number of Pole	$2p$	--			64		
Rated Current		I_r	A_{rms}	7.6		10.9		14.2	
Peak Current		I_p	A_{rms}	27.5		42.7		63.9	
Line Resistance		$R_{LL}@25^{\circ}C$	Ohm	3.38 ($\pm 20\%$)		2.1 ($\pm 20\%$)		1.54 ($\pm 20\%$)	
Line Inductance		$L_{LL}@60Hz$	mH	15.1 ($\pm 30\%$)		11.4 ($\pm 30\%$)		9.7 ($\pm 30\%$)	
MECHANICAL & THERMAL	Stator Weight	W_s	kg	7.39		12.87		24	
	Rotor Weight	W_r	kg	4.40		8.81		17.64	
	Total Weight	W_{total}	kg	11.79		21.68		41.64	
	Mech. Time Constant	K_{mech}	ms	2.50		1.88		1.56	
	Thermal Resistance ⁽²⁾	R_{th}	$^{\circ}C/W$	0.189		0.146		0.115	
	Inertia	J	kg.m ²	0.09193		0.18450		0.36966	
	Motor Constant	K_m	Nm/ \sqrt{W}	1.97	1.43	2.99	2.17	4.52	3.26
	Rotor ID		mm			270			
	Stator OD		mm			360			

1. All performance and electrical specifications are obtained at 25°C ambient and may change $\pm 10\%$. 2. Housed version of motor mounted to 550 mm sq. x 20 mm aluminum heat sink (maximum winding temperature is 120°C). 3. Higher torque and speed values as well as dimensions on request.

TM(L/H)-360 Torque-Speed Curves

Tr: Rated Torque
Tp: Peak Torque

— @Tr 24V - - - @Tr 48V
— @Tp 24V - - - @Tp 48V

— @Tr 310V - - - @Tr 560V
— @Tp 310V - - - @Tp 560V

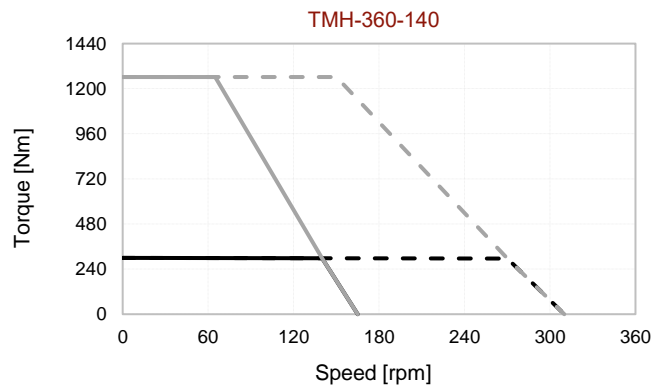
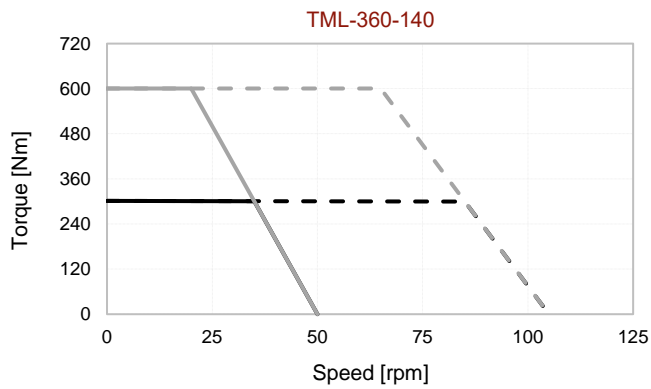
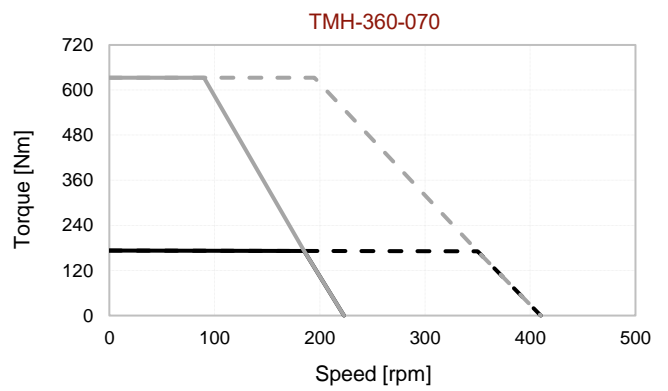
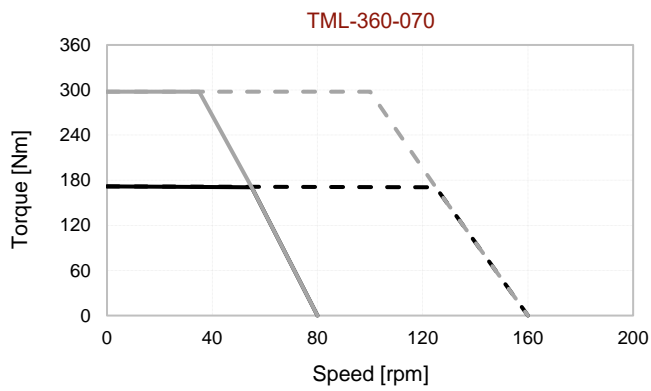
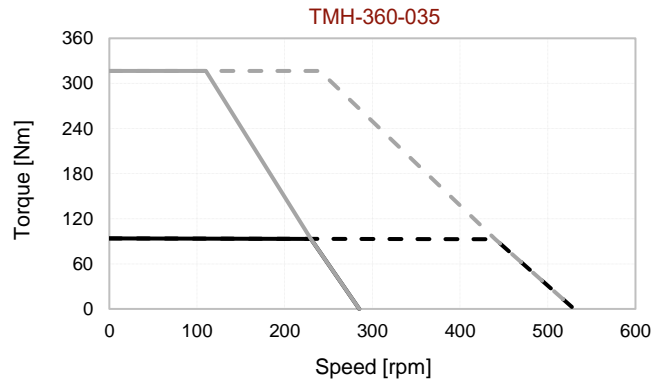
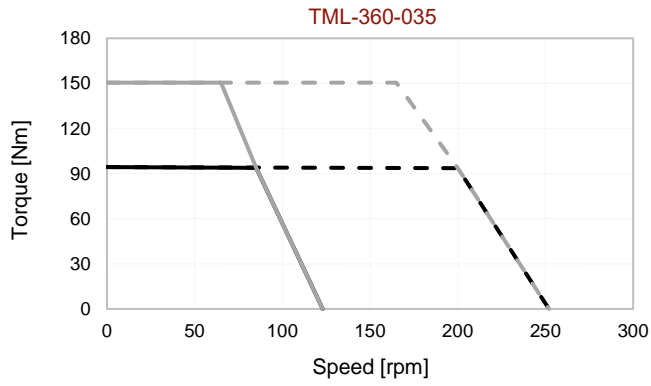

TM(L/H)-360 Outline Drawing

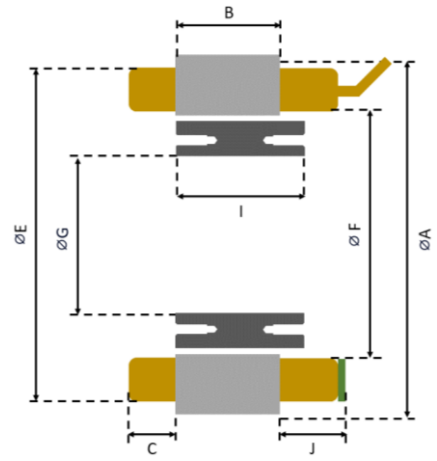
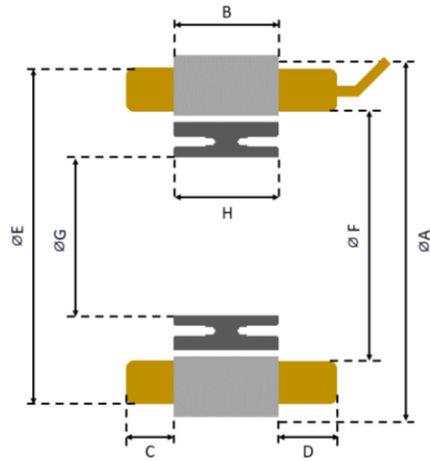

Hall Effect Sensor Option

Model	A (mm)	B (mm)	C (mm)	D (mm)	E (mm)	F (mm)	G (mm)	H (mm)	I (mm)	J (mm)
TM(L/H)-360-035	360	35	16	18	352	312.4	270	35.1	40.1	21
TM(L/H)-360-070	360	70	16	18	352	312.4	270	70.2	75.2	21
TM(L/H)-360-140	360	140	16	18	352	312.4	270	140.4	145.4	21

Notes:

MOTOR LEADS:

360-TML: #6 AWG Teflon® insulated, 500 mm (optional) length, 1-Red, 1-White, 1-Black.
 360-TMH: #10 AWG Teflon® insulated, 500 mm (optional) length, 1-Red, 1-White, 1-Black.

THERMISTOR LEADS:

#26 AWG Teflon® insulated, 500 mm (optional) length, 2-Brown or Blue.

SENSOR LEADS:

#23 AWG Teflon® insulated, 500 mm (optional) length, 1-Blue, 1-Green, 1-Brown, 1-White, 1-Yellow.

MOUNTING OPTION:

#Stator: 3x3 Keyway
 #Rotor: (16X on each side) M6 Bolt Hole (For details refer to MDS Motor mounting documents)

Motor Parameters		Symbols	Units	TML-372-035		TML-372-070		TML-372-140	
PERFORMANCE	DC Bus Voltage	V_{DC}	V	24	48	24	48	24	48
	Rated Torque	T_r	Nm	105.8		194.5		336.5	
	Peak Torque	T_p	Nm	168.8		337		669.6	
	Rated Speed	N_r	rpm	80	185	50	115	30	75
	No-Load Speed	$N_{no-load}$	rpm	110	225	70	140	45	90
	Torque Constant	K_t	Nm/A	2.42		3.87		5.8	
	Voltage Constant	K_v	V/rpm	0.208		0.333		0.498	
	Max. Cogging Torque	T_{cog}	%			<1			
	Torque Ripple	T_{ripple}	%			<1			
	ELECTRICAL	Number of Pole	$2p$	--			64		
Rated Current		I_r	A_{rms}	43.8		50.3		58	
Peak Current		I_p	A_{rms}	70.2		87.6		116	
Line Resistance		$R_{LL}@25^{\circ}C$	Ohm	0.1 ($\pm 20\%$)		0.1 ($\pm 20\%$)		0.095 ($\pm 20\%$)	
Line Inductance		$L_{LL}@60Hz$	mH	0.45 ($\pm 30\%$)		0.54 ($\pm 30\%$)		0.58 ($\pm 30\%$)	
MECHANICAL & THERMAL	Stator Weight	W_s	kg	6.23		11.28		21.42	
	Rotor Weight	W_r	kg	4.75		9.52		19.07	
	Total Weight	W_{total}	kg	10.98		20.8		40.49	
	Mech. Time Constant	K_{mech}	ms	2.39		1.82		1.53	
	Thermal Resistance ⁽²⁾	R_{th}	$^{\circ}C/W$	0.190		0.149		0.115	
	Inertia	J	kg.m ²	0.11166		0.22396		0.44857	
	Motor Constant	K_m	Nm/ \sqrt{W}	3.55	2.34	6.1	4.02	10.02	6.55
	Rotor ID		mm			287			
	Stator OD		mm			372			

Motor Parameters		Symbols	Units	TMH-372-035		TMH-372-070		TMH-372-140	
PERFORMANCE	DC Bus Voltage	V_{DC}	V	310	560	310	560	310	560
	Rated Torque	T_r	Nm	105.5		194.9		341	
	Peak Torque	T_p	Nm	358.9		717.9		1435.7	
	Rated Speed	N_r	rpm	215	405	170	325	130	245
	No-Load Speed	$N_{no-load}$	rpm	260	475	200	370	150	275
	Torque Constant	K_t	Nm/A	13.52		17.4		23.2	
	Voltage Constant	K_v	V/rpm	1.163		1.495		1.994	
	Max. Cogging Torque	T_{cog}	%			<1			
	Torque Ripple	T_{ripple}	%			<1			
	ELECTRICAL	Number of Pole	$2p$	--			64		
Rated Current		I_r	A_{rms}	7.8		11.2		14.7	
Peak Current		I_p	A_{rms}	28.3		44.1		66.1	
Line Resistance		$R_{LL}@25^{\circ}C$	Ohm	3.18 ($\pm 20\%$)		1.99 ($\pm 20\%$)		1.49 ($\pm 20\%$)	
Line Inductance		$L_{LL}@60Hz$	mH	14.28 ($\pm 30\%$)		10.86 ($\pm 30\%$)		9.24 ($\pm 30\%$)	
MECHANICAL & THERMAL	Stator Weight	W_s	kg	6.23		11.34		21.52	
	Rotor Weight	W_r	kg	4.75		9.52		19.07	
	Total Weight	W_{total}	kg	10.98		20.86		40.59	
	Mech. Time Constant	K_{mech}	ms	2.36		1.79		1.51	
	Thermal Resistance ⁽²⁾	R_{th}	$^{\circ}C/W$	0.190		0.149		0.115	
	Inertia	J	kg.m ²	0.11166		0.22396		0.44857	
	Motor Constant	K_m	Nm/ \sqrt{W}	2.16	1.58	3.31	2.39	5	3.65
	Rotor ID		mm			287			
	Stator OD		mm			372			

1. All performance and electrical specifications are obtained at 25°C ambient and may change $\pm 10\%$. 2. Housed version of motor mounted to 550 mm sq. x 20 mm aluminum heat sink (maximum winding temperature is 120°C). 3. Higher torque and speed values as well as dimensions on request.

TM(L/H)-372 Torque-Speed Curves

Tr: Rated Torque
Tp: Peak Torque

— @Tr 24V - - - @Tr 48V
— @Tp 24V - - - @Tp 48V

— @Tr 310V - - - @Tr 560V
— @Tp 310V - - - @Tp 560V

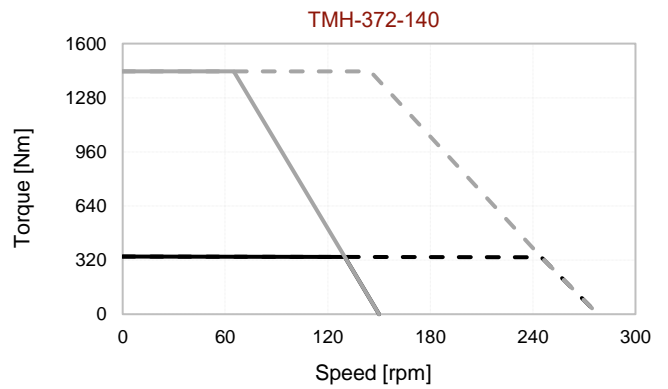
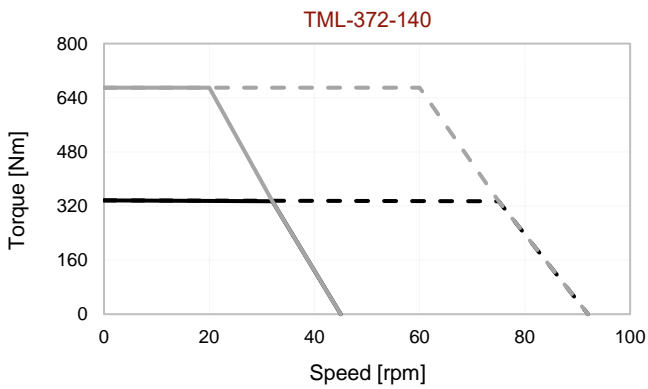
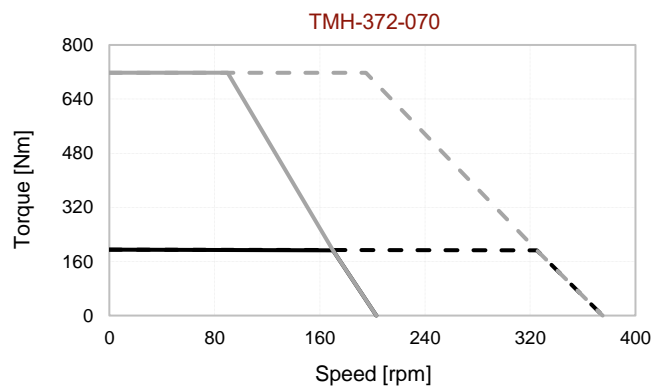
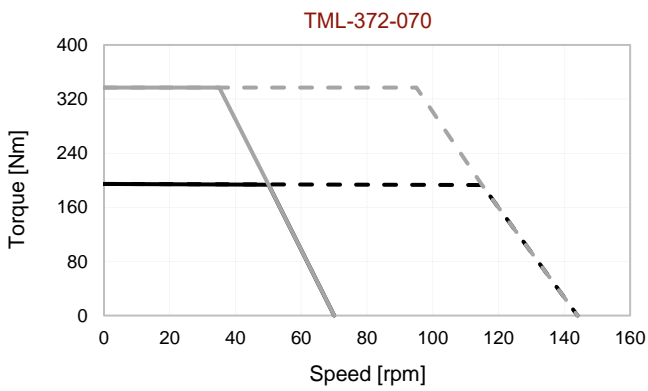
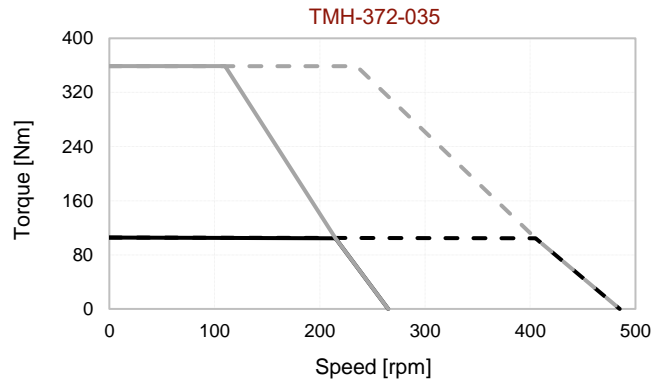
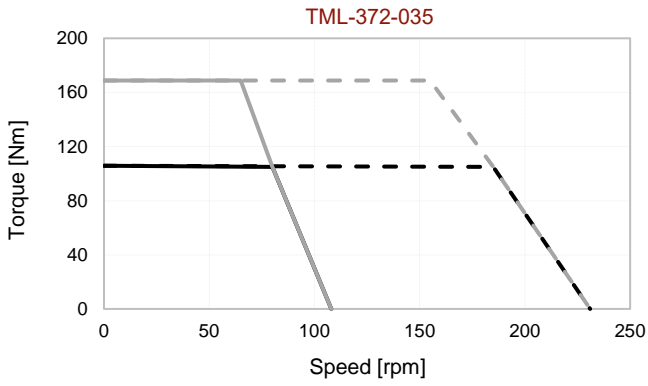

TM(L/H)-372 Outline Drawing

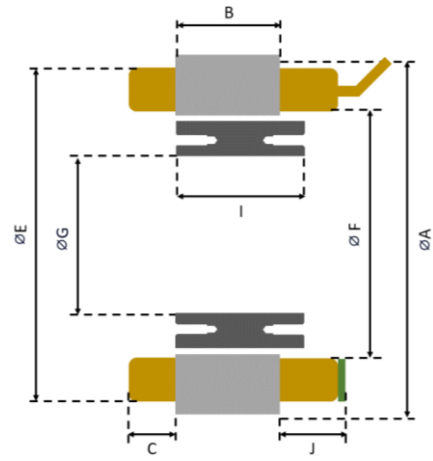
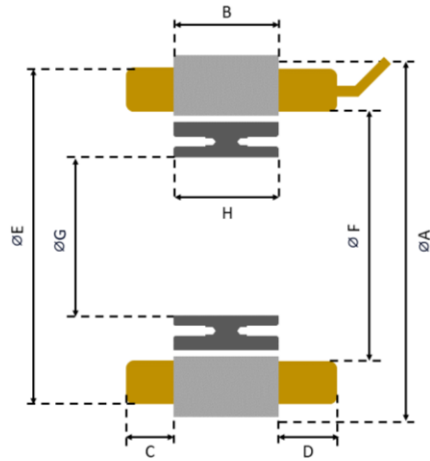

Hall Effect Sensor Option

Model	A (mm)	B (mm)	C (mm)	D (mm)	E (mm)	F (mm)	G (mm)	H (mm)	I (mm)	J (mm)
TM(L/H)-372-035	372	35	16	18	365	330.4	287	35.1	40.1	21
TM(L/H)-372-070	372	70	16	18	365	330.4	287	70.2	75.2	21
TM(L/H)-372-140	372	140	16	18	365	330.4	287	140.4	145.4	21

Notes:

MOTOR LEADS:

372-TML: #6 AWG Teflon® insulated, 500 mm (optional) length, 1-Red, 1-White, 1-Black.
 372-TMH: #10 AWG Teflon® insulated, 500 mm (optional) length, 1-Red, 1-White, 1-Black.

THERMISTOR LEADS:

#26 AWG Teflon® insulated, 500 mm (optional) length, 2-Brown or Blue.

SENSOR LEADS:

#23 AWG Teflon® insulated, 500 mm (optional) length, 1-Blue, 1-Green, 1-Brown, 1-White, 1-Yellow.

MOUNTING OPTION:

#Stator: 3x3 Keyway
 #Rotor: (16X on each side) M6 Bolt Hole (For details refer to MDS Motor mounting documents)

TRM-390 Technical Information

Motor Parameters		Symbols	Units	TML-390-035		TML-390-070		TML-390-140	
PERFORMANCE	DC Bus Voltage	V_{DC}	V	24	48	24	48	24	48
	Rated Torque	T_r	Nm	108.5		199.2		361.7	
	Peak Torque	T_p	Nm	179.3		359.6		717.4	
	Rated Speed	N_r	rpm	80	185	50	115	30	75
	No-Load Speed	$N_{no-load}$	rpm	110	225	70	140	45	90
	Torque Constant	K_t	Nm/A	2.41		3.88		5.79	
	Voltage Constant	K_v	V/rpm	0.207		0.331		0.496	
	Max. Cogging Torque	T_{cog}	%			<1			
	Torque Ripple	T_{ripple}	%			<1			
	ELECTRICAL	Number of Pole	$2p$	--			64		
Rated Current		I_r	A_{rms}	45		51.3		62.5	
Peak Current		I_p	A_{rms}	75		93.4		125	
Line Resistance		$R_{LL}@25^{\circ}C$	Ohm	0.1 ($\pm 20\%$)		0.11 ($\pm 20\%$)		0.08 ($\pm 20\%$)	
Line Inductance		$L_{LL}@60Hz$	mH	0.48 ($\pm 30\%$)		0.55 ($\pm 30\%$)		0.59 ($\pm 30\%$)	
MECHANICAL & THERMAL	Stator Weight	W_s	kg	8.93		16		30.4	
	Rotor Weight	W_r	kg	4.98		10.0		20.0	
	Total Weight	W_{total}	kg	13.91		26.00		50.40	
	Mech. Time Constant	K_{mech}	ms	2.47		2.03		1.47	
	Thermal Resistance ⁽²⁾	R_{th}	$^{\circ}C/W$	0.190		0.152		0.114	
	Inertia	J	kg.m ²	0.11997		0.24057		0.48177	
	Motor Constant	K_m	Nm/ \sqrt{W}	3.6	2.37	6.17	4.07	10.73	6.79
	Rotor ID		mm			290			
	Stator OD		mm			390			

Motor Parameters		Symbols	Units	TMH-390-035		TMH-390-070		TMH-390-140	
PERFORMANCE	DC Bus Voltage	V_{DC}	V	310	560	310	560	310	560
	Rated Torque	T_r	Nm	109.6		199.7		361.1	
	Peak Torque	T_p	Nm	378.3		747.5		1483	
	Rated Speed	N_r	rpm	220	420	170	325	130	245
	No-Load Speed	$N_{no-load}$	rpm	270	495	200	370	150	275
	Torque Constant	K_t	Nm/A	12.89		17.36		23.15	
	Voltage Constant	K_v	V/rpm	1.116		1.489		1.985	
	Max. Cogging Torque	T_{cog}	%			<1			
	Torque Ripple	T_{ripple}	%			<1			
	ELECTRICAL	Number of Pole	$2p$	--			64		
Rated Current		I_r	A_{rms}	8.5		11.5		15.6	
Peak Current		I_p	A_{rms}	32		47.3		70.2	
Line Resistance		$R_{LL}@25^{\circ}C$	Ohm	2.8 ($\pm 20\%$)		1.82 ($\pm 20\%$)		1.35 ($\pm 20\%$)	
Line Inductance		$L_{LL}@60Hz$	mH	13.7 ($\pm 30\%$)		11.2 ($\pm 30\%$)		9.4 ($\pm 30\%$)	
MECHANICAL & THERMAL	Stator Weight	W_s	kg	9.07		16.19		30	
	Rotor Weight	W_r	kg	4.98		10.0		20.0	
	Total Weight	W_{total}	kg	14.05		26.19		50.00	
	Mech. Time Constant	K_{mech}	ms	2.44		1.77		1.47	
	Thermal Resistance ⁽²⁾	R_{th}	$^{\circ}C/W$	0.190		0.152		0.114	
	Inertia	J	kg.m ²	0.11997		0.24057		0.48177	
	Motor Constant	K_m	Nm/ \sqrt{W}	2.18	1.58	3.35	2.42	5.15	3.75
	Rotor ID		mm			290			
	Stator OD		mm			390			

1. All performance and electrical specifications are obtained at 25°C ambient and may change $\pm 10\%$. 2. Housed version of motor mounted to 550 mm sq. x 20 mm aluminum heat sink (maximum winding temperature is 120°C). 3. Higher torque and speed values as well as dimensions on request.

TM(L/H)-390 Torque-Speed Curves

Tr: Rated Torque
Tp: Peak Torque

— @Tr 24V - - - @Tr 48V
— @Tp 24V - - - @Tp 48V

— @Tr 310V - - - @Tr 560V
— @Tp 310V - - - @Tp 560V

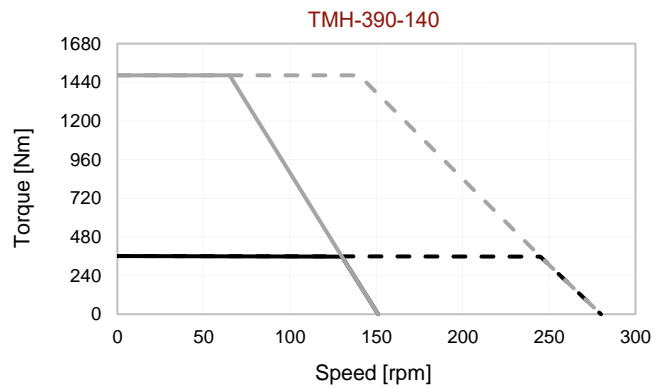
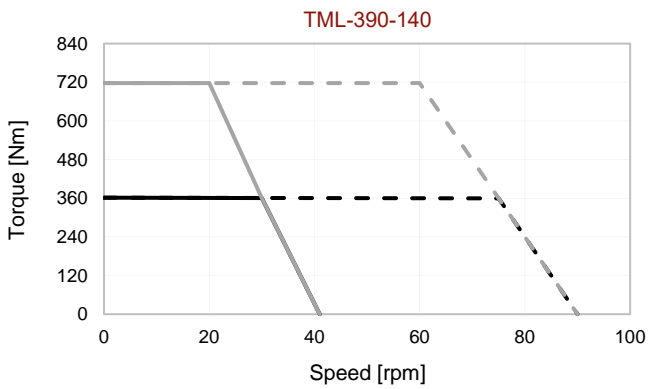
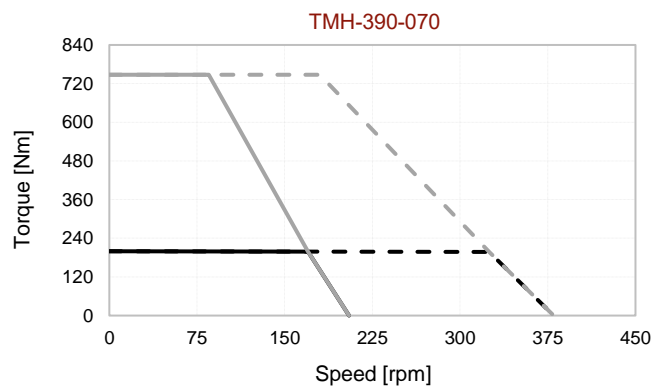
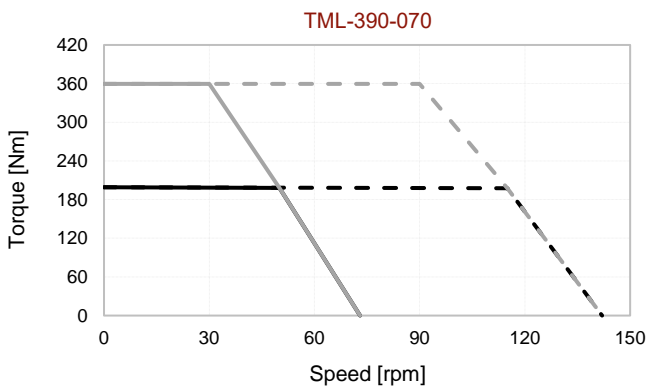
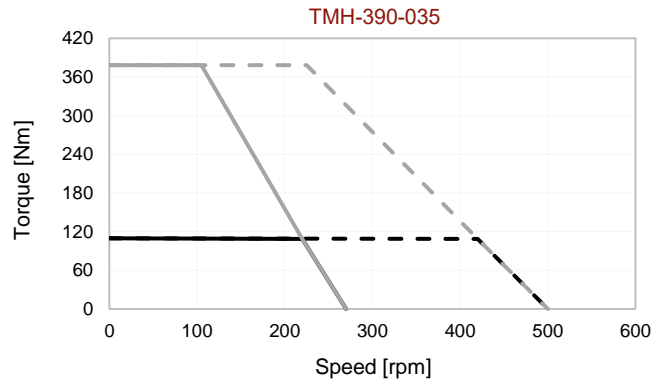
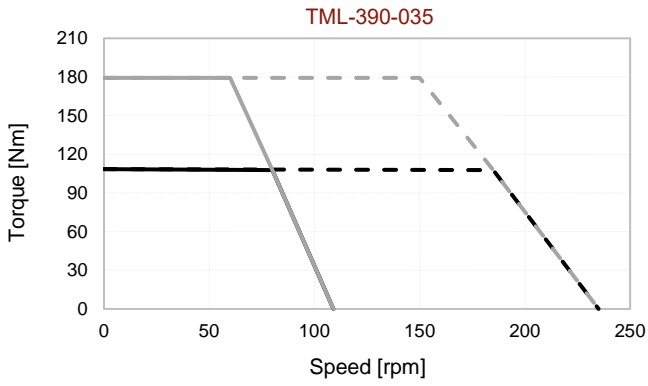

TM(L/H)-390 Outline Drawing

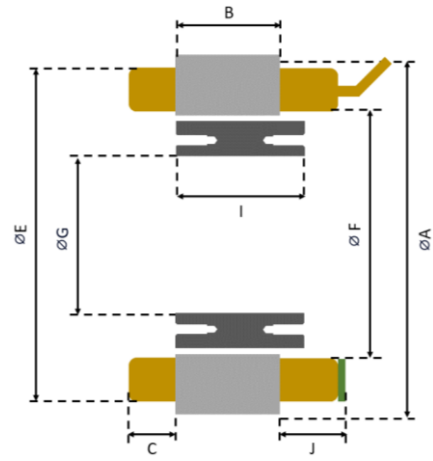
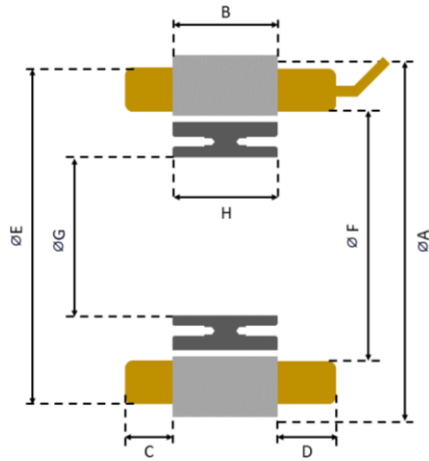

Hall Effect Sensor Option

Model	A (mm)	B (mm)	C (mm)	D (mm)	E (mm)	F (mm)	G (mm)	H (mm)	I (mm)	J (mm)
TM(L/H)-390-035	390	35	16	18	378	334.3	290	35.1	40.1	21
TM(L/H)-390-070	390	70	16	18	378	334.3	290	70.2	75.2	21
TM(L/H)-390-140	390	140	16	18	378	334.3	290	140.4	145.4	21

Notes:

MOTOR LEADS:

390-TML: #6 AWG Teflon® insulated, 500 mm (optional) length, 1-Red, 1-White, 1-Black.
 390-TMH: #10 AWG Teflon® insulated, 500 mm (optional) length, 1-Red, 1-White, 1-Black.

THERMISTOR LEADS:

#26 AWG Teflon® insulated, 500 mm (optional) length, 2-Brown or Blue.

SENSOR LEADS:

#23 AWG Teflon® insulated, 500 mm (optional) length, 1-Blue, 1-Green, 1-Brown, 1-White, 1-Yellow.

MOUNTING OPTION:

#Stator: 3x3 Keyway
 #Rotor: (16X on each side) M6 Bolt Hole (For details refer to MDS Motor mounting documents)

Hall Effect Sensor Information

Motor and Sensor Cable Information

"A"	Red
"B"	White
"C"	Black
+5V to +24V	Blue
GND	Green
H1	Brown
H2	White
H3	Yellow

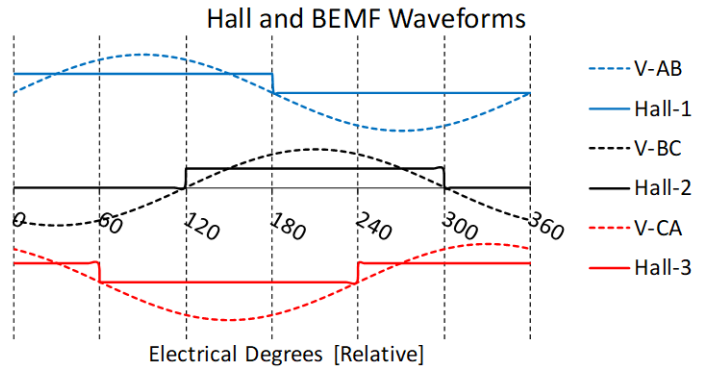

Electrical Degree°	Communication Channel Sequence			Motor Phase Excitation Sequence ¹		
	H1	H2	H3	A	B	C
0 – 60	1	0	1		-	+
60 – 120	1	0	0	+	-	
120 – 180	1	1	0	+		-
180 – 240	0	1	0		+	-
240 – 300	0	1	1	-	+	
300 – 360	0	0	1	-		+

Notes: ¹When the values in the table are applied to the phase excitation signals and viewed from the direction of the motor cables, it is observed that the motor rotates clockwise

Motor Design Sheet

Please send your inquiry to
mds@mdsmotor.com or fax: +90 (262) 341 4472

Contact details	
Company:	
Name:	
Tel:	
Email:	
Application/Project:	

Specifications for motor design

Required torques			
Rated torque [Nm]			
Rated speed [rpm]			
Max. torque [Nm]			
Max speed [rpm]			
Electrical specifications			
DC bus voltage [V]			
Rated current [Arms]			
Max current [Arms]			
Current supply	BLDC / BLAC		
Motor size limits			
Max. diameter allowed [mm]			
Max. length allowed [mm]			
Weigth limit if any [kg]			
Inertia req. if any			
Cooling / Construction			
Ambient temp. [oC]			
Housing / cooling type	<input type="checkbox"/> None	<input type="checkbox"/> Air cooled	<input type="checkbox"/> Water cooled
Duty cycle			
Other / Comments			
Rotor type	Surface / IPM / other...		
Torque-speed curve – please draw			
Comments			

Revision No	Version No	Made By	Date
12	V28	OS	01.10.2024



MDS Motor Ltd.

Kocaeli Üniversitesi TEKNOPARK
Vatan Caddesi, No:83 / C:19
41275, Başiskele, Kocaeli, TURKEY

P: +90 (262)-341-4470

F: +90 (262)-341-4472

E-mail: mds@mdsmotor.com

Website: www.mdsmotor.com

MDS Motor © 2024. All rights reserved.

Information in this catalogue is subject to change without previous notice

