

LVSM Series Servo Motors

60-140 OD Frame Size

www.mdsmotor.com

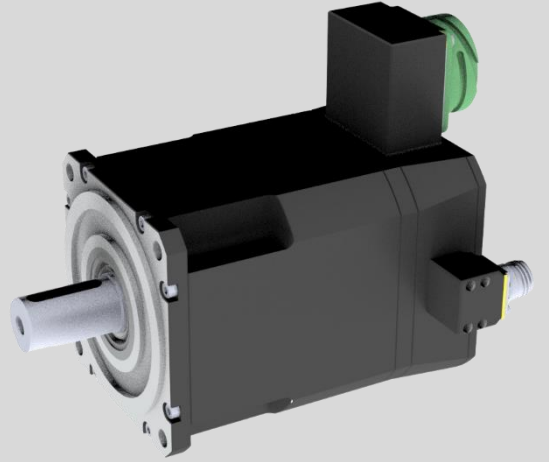

MDS Motor
Feel the perfect motion...

Kocaeli Üniversitesi Teknopark |
Vatan Cad. No:83 |41275 |
Başiskele, Kocaeli, Türkiye

Table of Content

MDS – LVSM Series Servo Motors	1
LVSM Series Servo Motors Nomenclature	2
Definitions of Motor Parameters	3
LVSM-060 Datasheet	4
LVSM-070 Datasheet	8
LVSM-080 Datasheet	12
LVSM-090 Datasheet	16
LVSM-100 Datasheet	20
LVSM-115 Datasheet	24
LVSM-130 Datasheet	28
LVSM-140 Datasheet	32
Resolver Information	36
Motor Design Sheet	37
Notes	38

LVSM Series Servo Motors

High performance AC synchronous servo motors

MDS Motor offers high-quality, reliable permanent magnet synchronous motor family designed for low DC bus voltage applications such as defense and aerospace. This new servo motor family is called Low Voltage Synchronous Servo Motor (LVSM). They offer 8 frame sizes with various stack options for both 24V and 48V DC bus levels.

LVSM series servo motors are engineered for harsh environmental conditions.

- High torque density motors
- IP65 and IP67 sealing requirements
- Suited for diverse military specifications

Main Features and Benefits

- Peaks torques up to 140Nm
- Max rated speeds up to 4000rpm
- Extremely low cogging torque at low speeds (usually less than 1% of rated)
- Low torque ripple (usually less than 1% of rated)
- 24V and 48V DC Bus options
- Rugged MYM series resolver or encoder feedback options
- Low THD on back-EMF voltage
- Temperature range of -30°C to 54°C with H class insulation materials
- IP65 / IP67 protection available
- Standard international mounting available
- Electromagnetic brake and no-brake options
- Optional shaft configurations

Description of LVSM Servo Motor Series

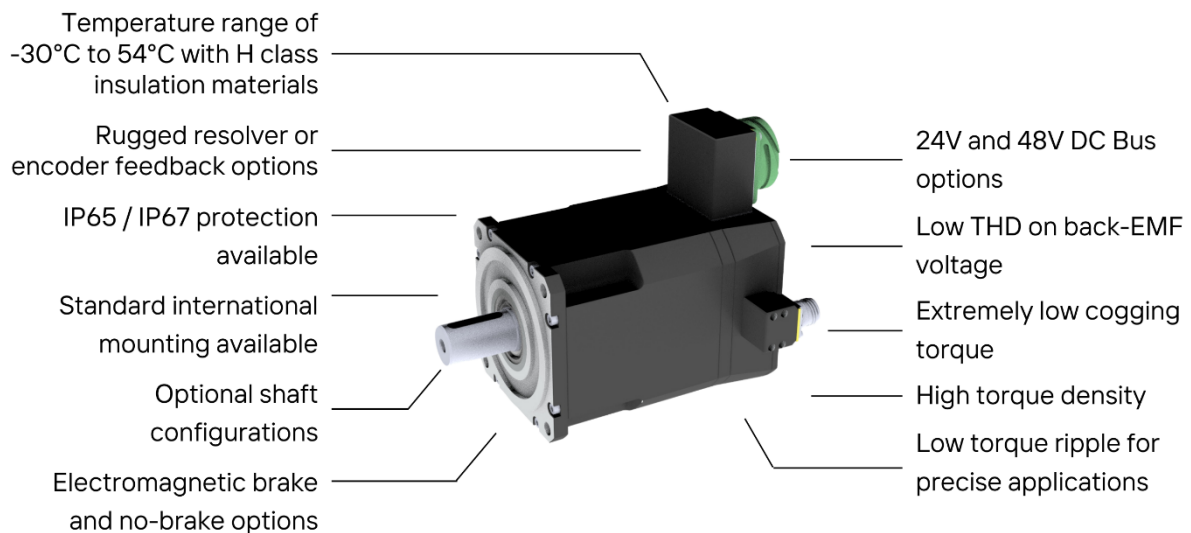

LVSM Series Servo Motors Nomenclature

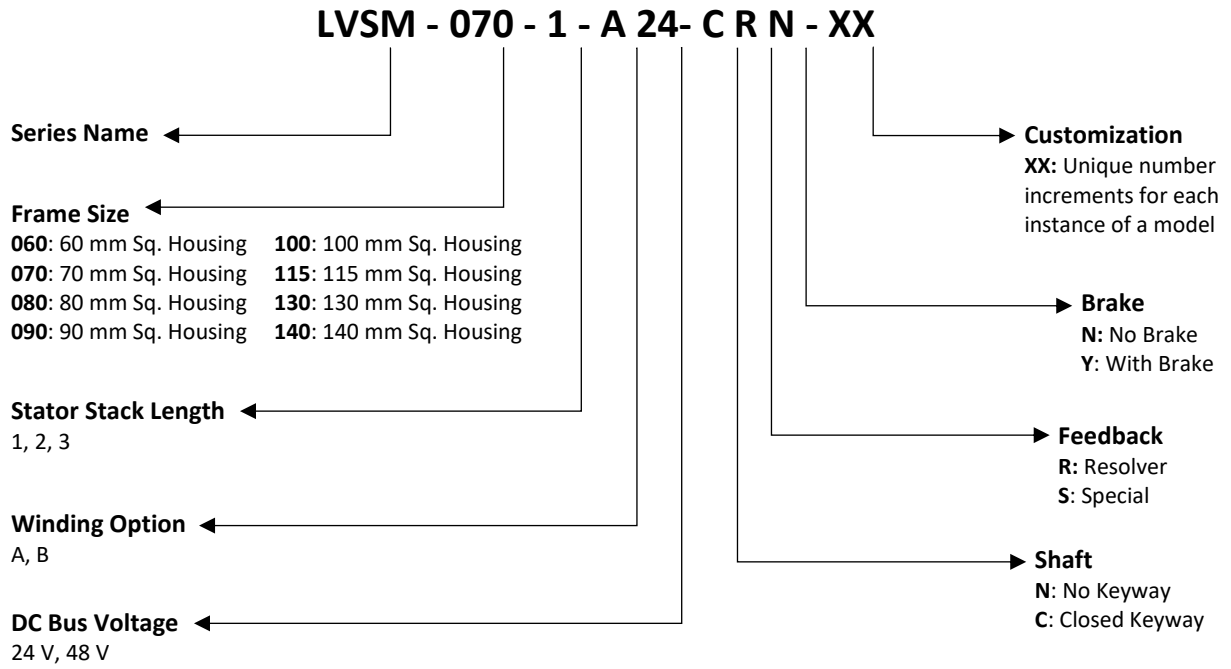

Definition of Motor Parameters

Rated Torque	T_r	Torque value at rated speed when continuous power is the output
Peak Torque	T_p	Maximum torque that the motor delivers when maximum current (I_p) is provided. Peak torque is available for a maximum of 2 seconds
Rated Speed	N_r	Speed at continuous power is the output
No-Load Speed	$N_{no-load}$	Maximum possible speed of motor that it can be electrically excited
Torque Constant	K_t	Ratio of the developed torque to input current
Voltage Constant	K_v	Ratio of voltage generated in the winding to rotor speed
Max. Cogging Torque	T_{cog}	Undesirable torque component arising from attractions between magnets and teeth. Cogging torque is minimized for each MDS's torque motor is less than 0.5 % of the rated torque
Torque Ripple	T_{ripple}	Undesirable torque component arising from attractions between stator MMF and magnets
Num. of Pole	$2p$	Number of poles
Rated Current	I_r	Current required to obtain the rated continuous torque
Peak Current	I_p	Current required to obtain peak torque from the motor
Line Resistance	R_{LL}	Cold (25°C) resistance measured between two leads of the winding
Line Inductance	L_{LL}	Inductance measured between two leads of the AC winding (@60Hz)
Stator Weight	W_s	Total weight of stator laminations including windings
Rotor Weight	W_r	Total weight of rotor laminations and magnets
Total Weight	W_{total}	Total weight of stator and rotor weight
Mech. Time Constant	K_{mech}	Motor mechanical dynamic capability level
Thermal Resistance	R_{th}	Ratio of winding temperature rise to average stator power loss at rated motor operation
Inertia	J	Inertia of the rotor including rotor core and magnets
Motor Constant	K_m	Ratio of peak torque to square root of input power: $K_m = T_{peak}/(P_{peak})^{.5}$. It shows the ability of a motor to convert electrical power to torque
Rotor ID		Rotor inner diameter of the motor
Stator OD		Stator outer diameter of the motor

NOTE: All performance data is obtained at 25°C ambient

LVSM-060 Technical Information

Motor Parameters			LVSM-060-01				LVSM-060-02				LVSM-060-03				
Winding Type	Symbols	Units	A		B		A		B		A		B		
PERFORMANCE	DC Bus Voltage	V _{dc}	24	48	24	48	24	48	24	48	24	48	24	48	
	Rated Power	P _r	162	367	217	456	297	632	451	875	472	940	573	1066	
	Stall Torque	T _s	0.70	0.70	0.69	0.69	1.27	1.27	1.28	1.28	1.76	1.76	1.70	1.70	
	Rated Torque	T _r	0.68	0.66	0.67	0.63	1.22	1.15	1.20	1.07	1.64	1.48	1.59	1.38	
	Peak Torque	T _p	2.36	2.36	2.36	2.36	4.72	4.72	4.71	4.71	7.08	7.08	7.07	7.07	
	Rated Speed	N _r	rpm	2275	5275	3100	6900	2325	5250	3600	7800	2750	6050	3450	7400
	No-Load Speed ⁽²⁾	N _{no-load}	rpm	3404	6809	4309	8618	3235	6469	4615	9231	3593	7186	4309	8618
	Torque Constant	K _t	Nm/ A _{rms}	0.08	0.08	0.06	0.06	0.09	0.09	0.06	0.06	0.08	0.08	0.06	0.07
	Voltage Constant ⁽²⁾	K _v	V _{rms} /krpm	4.99	4.99	3.94	3.94	5.25	5.25	3.68	3.68	4.72	4.72	3.94	3.94
ELECTRICAL	Stall Current	I _s	8.60	8.60	10.7	10.7	14.7	14.7	21.2	21.2	22.5	22.5	26.2	26.2	
	Rated Current	I _r	8.50	8.25	10.5	10.1	14.3	13.6	20.2	18.4	21.4	19.7	25.0	22.0	
	Peak Current	I _p	31.0	31.0	39.2	39.2	59.0	59.0	84.0	84.0	98.3	98.3	117.7	117.7	
	Line Resistance ⁽²⁾	R _{LL}	mOhm	350 (±20%)	350 (±20%)	218 (±20%)	218 (±20%)	159 (±20%)	159 (±20%)	71.2 (±20%)	71.2 (±20%)	73.8 (±20%)	73.8 (±20%)	47.8 (±20%)	47.8 (±20%)
	Line Inductance ⁽²⁾	L _{LL}	mH	0.39 (±30%)	0.39 (±30%)	0.24 (±30%)	0.24 (±30%)	0.21 (±30%)	0.21 (±30%)	0.10 (±30%)	0.10 (±30%)	0.11 (±30%)	0.11 (±30%)	0.08 (±30%)	0.08 (±30%)
	Inertia (without brake)	J	kg.cm ²	0.155	0.155	0.155	0.155	0.26	0.26	0.26	0.26	0.37	0.37	0.37	0.37
	Weight (without brake)	W	kg	1.43	1.43	1.43	1.43	1.80	1.80	1.80	1.80	2.16	2.16	2.16	2.16
	Thermal Resistance ⁽²⁾	K _{therm}	C°/W	2.72	2.48	2.76	2.32	2.05	1.82	2.10	1.62	1.86	1.51	1.94	1.43
	Mech. Time Constant	K _{mech}	ms	0.99	0.98	0.98	0.99	0.67	0.67	0.62	0.62	0.55	0.55	0.51	0.51
	Motor Constant	K _m	Nm/VW	0.11	0.12	0.12	0.12	0.18	0.19	0.19	0.21	0.25	0.27	0.25	0.29
FEEDBACK	Pole Number	n	10												
	Input Voltage	V _{rms}	5												
	Frequency	kHz	4.5												
	Input Current	mA	58												
	Transformation Ratio		0.5±10%												
	Null Voltage	mV _{max}	30												
	Phase Shift	Deg	-15°±2°												

1. All performance and electrical specifications are obtained at 25°C ambient and may change ±10%. 2. Rated data with reference aluminum plate 250mm x 250mm x 6mm (maximum winding temperature is 120°C). 3. Higher torque and speed values as well as dimensions on request.

LVSM-060 Torque-Speed Curves

Tr: Rated Torque — @Tr 24V - - - @Tr 48V
 Tp: Peak Torque — @Tp 24V - - - @Tp 48V

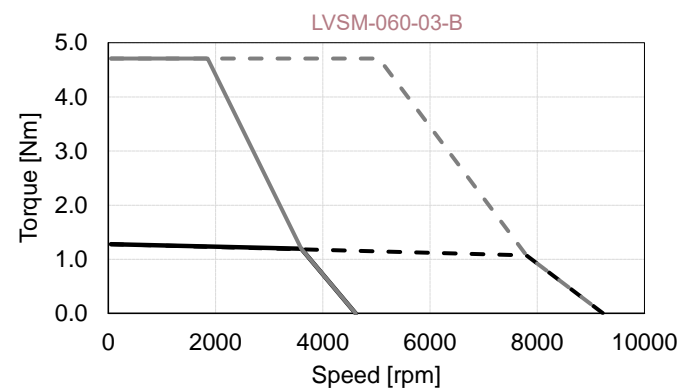
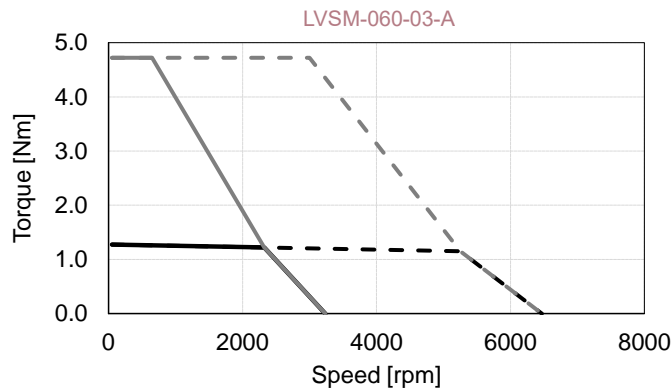
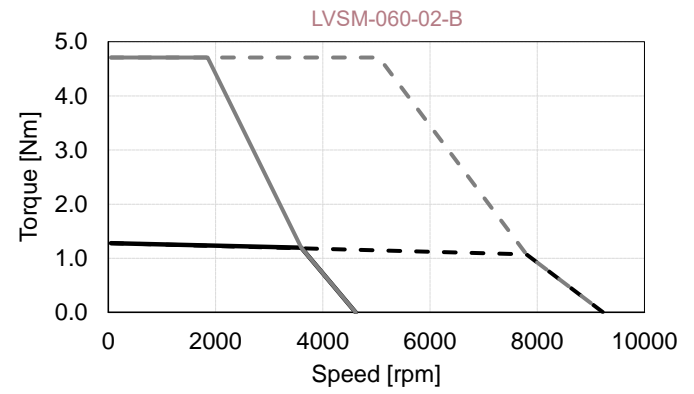
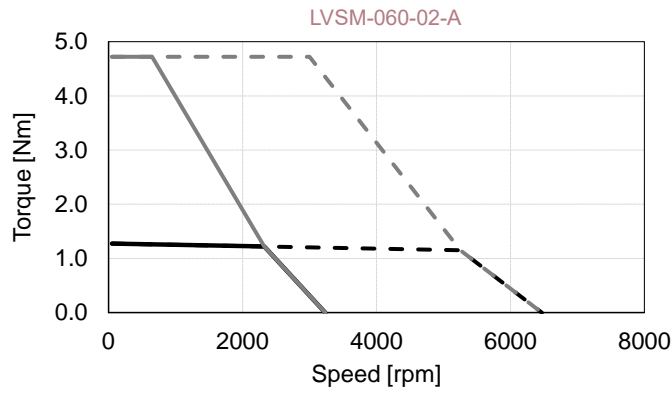
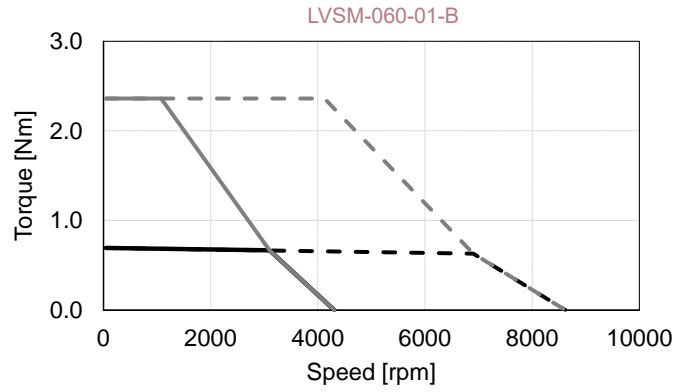
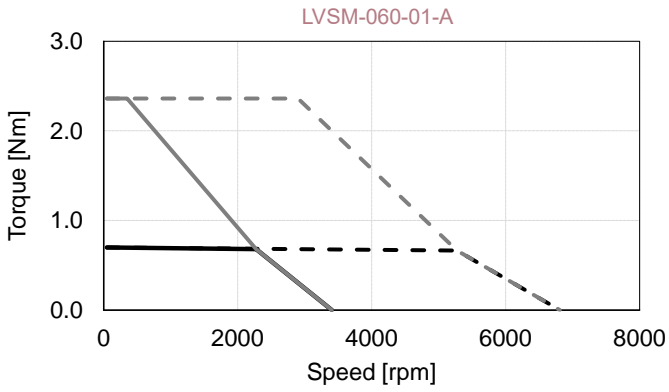

LVSM-060 Outline Drawing

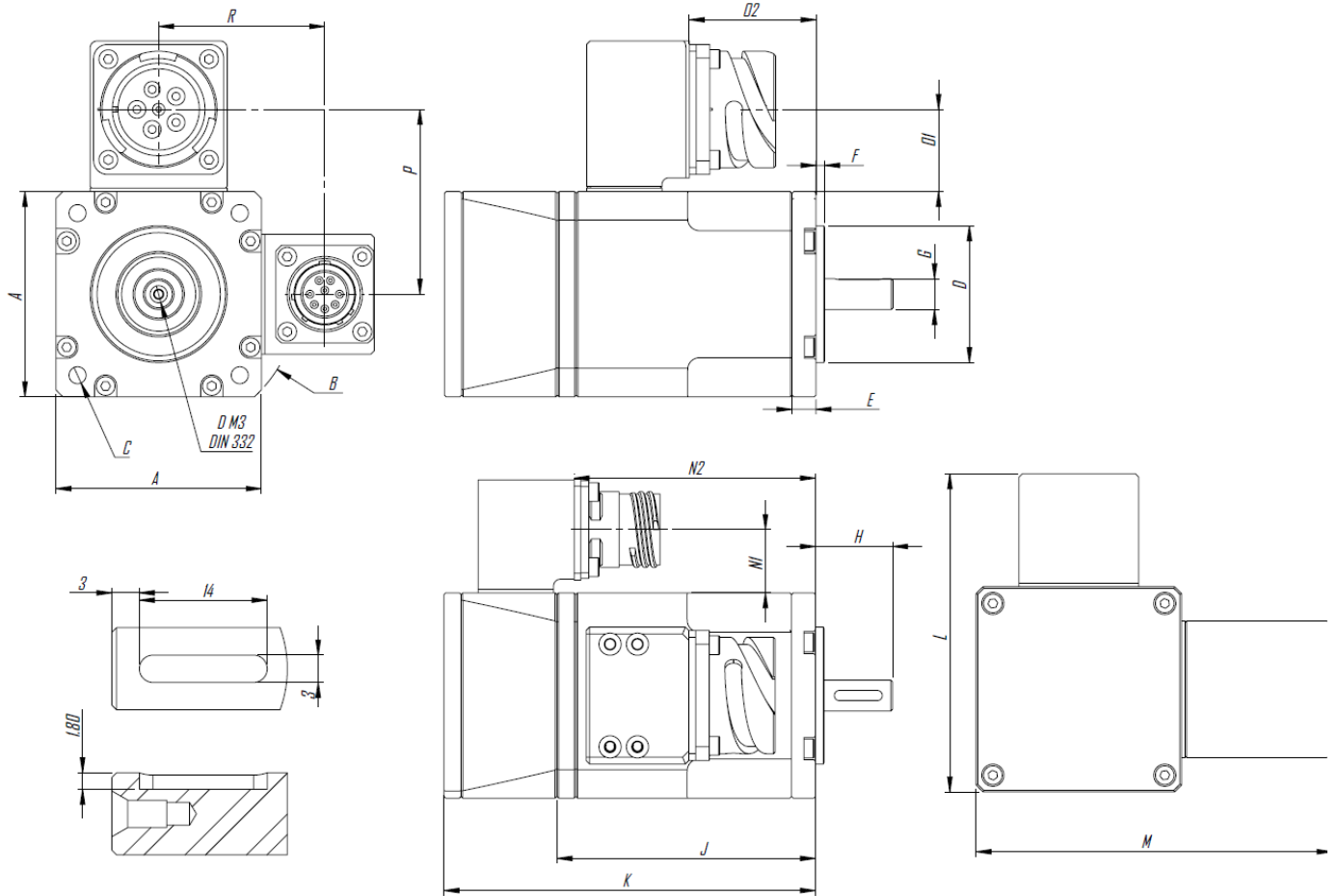

Symbols	Units	Frensiz			Frenli		
		LVSM-060-01	LVSM-060-02	LVSM-060-03	LVSM-060-01	LVSM-060-02	LVSM-060-03
A	mm	60	60	60	60	60	60
B	mm	Ø82	Ø82	Ø82	Ø82	Ø82	Ø82
C	mm	Ø 5 on Ø67	Ø 5 on Ø67	Ø 5 on Ø67	Ø 5 on Ø67	Ø 5 on Ø67	Ø 5 on Ø67
D	mm	Ø40	Ø40	Ø40	Ø40	Ø40	Ø40
E	mm	7	7	7	7	7	7
F	mm	2.5	2.5	2.5	2.5	2.5	2.5
G	mm	Ø 9	Ø 9	Ø 9	Ø 9	Ø 9	Ø 9
J	mm	78	96	116	78	96	116
K	mm	109	129	149	153	173	193
L	mm	93	93	93	93	93	93
M	mm	104	104	104	104	104	104
N1	mm	19	19	19	19	19	19
N2	mm	71	91	111	116	136	156
O1	mm	23	23	23	23	23	23
O2	mm	37	57	77	37	57	77
P	mm	54	54	54	54	54	54
R	mm	49	49	49	49	49	49

Power - Signal Connector

Power Connector (CB2-20-22-PC-FM)

Pin	Function	Description
A	A	Phase A
B	-	-
C	C	Phase C
D	-	-
E	B	Phase B
F	GND	GND

Signal Connector (D38999/20WC8PN)

Pin	Function	Description
A	R1	Ref (+)
B	R2	Ref (-)
C	S1	Cos (+)
D	S3	Cos (-)
E	S2	Sin (+)
F	S4	Sin (-)
G	NTC	Thermal Sensor
H	NTC	Thermal Sensor

LVSM-070 Technical Information

	Motor Parameters	Symbols	Units	LVSM-070-01				LVSM-070-02				LVSM-070-03			
				Winding Type		A		B		A		B		A	
PERFORMANCE	DC Bus Voltage	V_{dc}	V	24	48	24	48	24	48	24	48	24	48	24	48
	Rated Power	P_r	W	0.36	0.75	0.47	0.94	0.58	1.18	0.74	1.42	0.65	1.36	0.78	1.52
	Stall Torque	T_s	Nm	1.36	1.36	1.20	1.20	2.42	2.42	2.39	2.39	3.25	3.25	3.27	3.27
	Rated Torque	T_r	Nm	1.32	1.26	1.31	1.21	2.32	2.14	2.28	2.02	3.10	2.94	3.13	2.84
	Peak Torque	T_p	Nm	4.56	4.56	4.57	4.57	9.13	9.13	9.13	9.13	13.7	13.7	13.7	13.7
	Rated Speed	N_r	rpm	2600	5675	3450	7450	2400	5250	3100	6700	2000	4400	2375	5100
	No-Load Speed ⁽²⁾	$N_{no-load}$	rpm	3463	6926	4453	8905	3117	6234	3896	7792	2597	5195	2970	5941
	Torque Constant	K_t	Nm/ A_{rms}	0.08	0.08	0.06	0.06	0.09	0.09	0.07	0.07	0.11	0.11	0.09	0.09
	Voltage Constant ⁽²⁾	K_v	$V_{rms}/krpm$	4.90	4.90	3.81	3.81	5.44	5.44	4.36	4.36	6.53	6.53	5.71	5.71
ELECTRICAL	Stall Current	I_s	A_{rms}	16.9	16.9	19.1	19.1	26.9	26.9	33.1	33.1	30.1	30.1	34.6	34.6
	Rated Current	I_r	A_{rms}	16.6	16.0	21.2	19.8	26.1	24.4	32.1	28.8	29.2	27.8	33.6	30.7
	Peak Current	I_p	A_{rms}	57.9	57.9	74.3	74.3	104.0	104.0	130.0	130.0	130.0	130.0	149.0	149.0
	Line Resistance ⁽²⁾	R_{LL}	mOhm	108 (±20%)	108 (±20%)	74 (±20%)	74 (±20%)	60 (±20%)	60 (±20%)	40 (±20%)	40 (±20%)	56 (±20%)	56 (±20%)	41 (±20%)	41 (±20%)
	Line Inductance ⁽²⁾	L_{LL}	mH	0.17 (±30%)	0.17 (±30%)	0.10 (±30%)	0.10 (±30%)	0.10 (±30%)	0.10 (±30%)	0.07 (±30%)	0.07 (±30%)	0.10 (±30%)	0.10 (±30%)	0.07 (±30%)	0.07 (±30%)
	Inertia (without brake)	J	kg.cm ²	0.035	0.035	0.035	0.035	0.69	0.69	0.69	0.69	0.93	0.93	0.93	0.93
	Weight (without brake)	W	kg	1.91	1.91	1.91	1.91	2.71	2.71	2.71	2.71	3.47	3.47	3.48	3.48
	Thermal Resistance ⁽²⁾	K_{therm}	C°/W	2.09	1.77	1.80	1.47	1.48	1.26	1.39	1.12	1.27	1.13	1.27	1.07
	Mech. Time Constant	K_{mech}	ms	0.07	0.07	0.08	0.08	0.63	0.63	0.66	0.66	0.55	0.55	0.52	0.52
	Motor Constant	K_m	Nm/ VW	0.20	0.21	0.17	0.18	0.31	0.33	0.30	0.34	0.38	0.40	0.39	0.43
	Pole Number	n		10											
FEEDBACK	Input Voltage		V_{rms}	5											
	Frequency		kHz	4.5											
	Input Current		mA	58											
	Transformation Ratio			0.5±10%											
	Null Voltage		mV_{max}	30											
	Phase Shift		Deg	-15°±2°											

1. All performance and electrical specifications are obtained at 25°C ambient and may change ±10%. 2. Rated data with reference aluminum plate 250mm x 250mm x 6mm (maximum winding temperature is 120°C). 3. Higher torque and speed values as well as dimensions on request.

LVSM-070 Torque-Speed Curves

Tr: Rated Torque — @Tr 24V - - - @Tr 48V
 Tp: Peak Torque — @Tp 24V - - - @Tp 48V

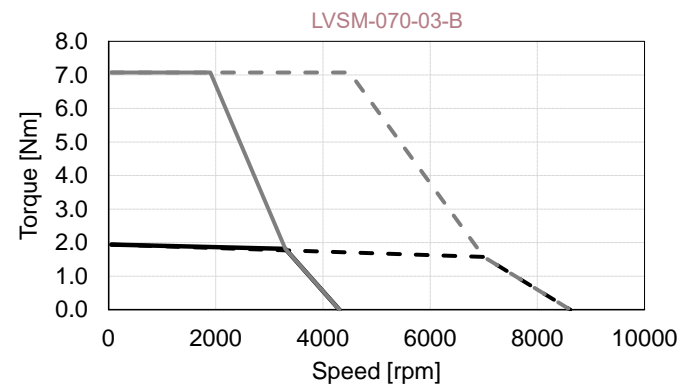
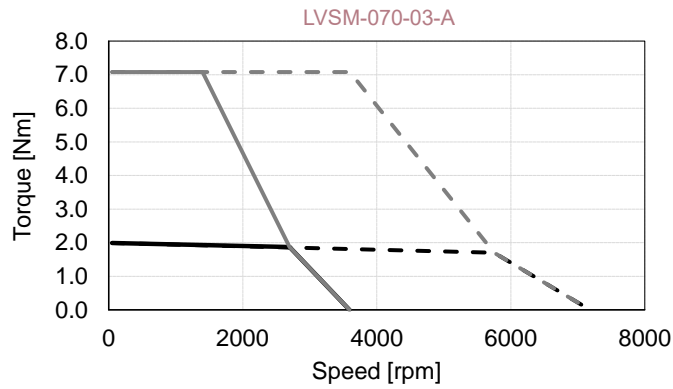
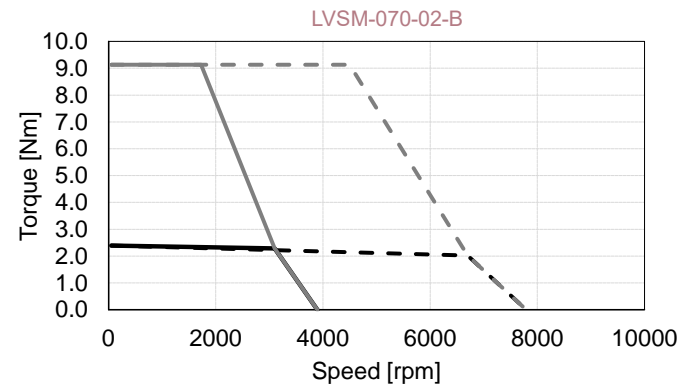
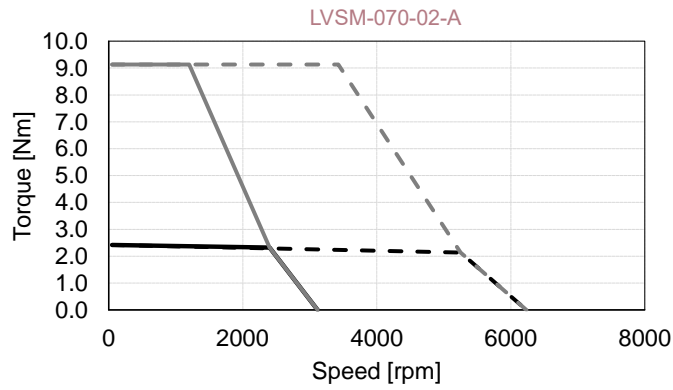
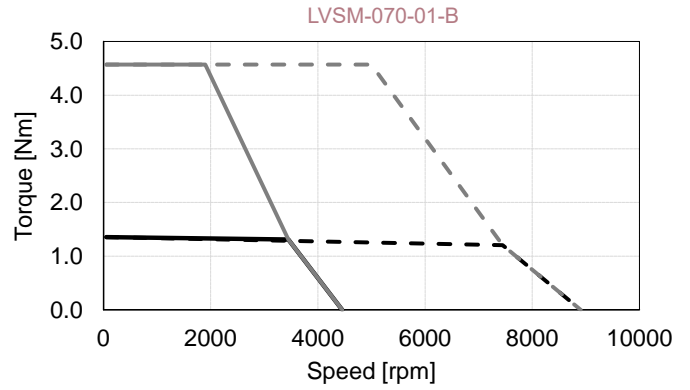
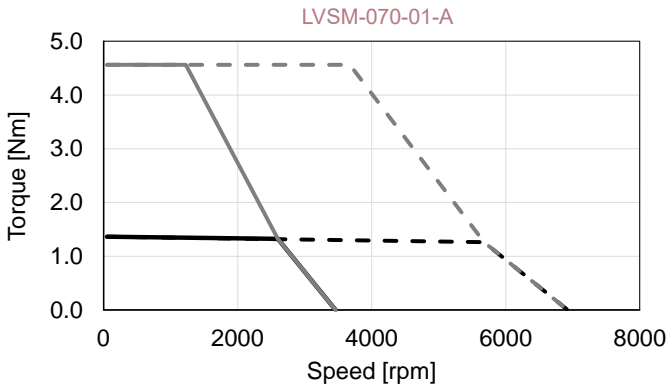

LVSM-070 Outline Drawing

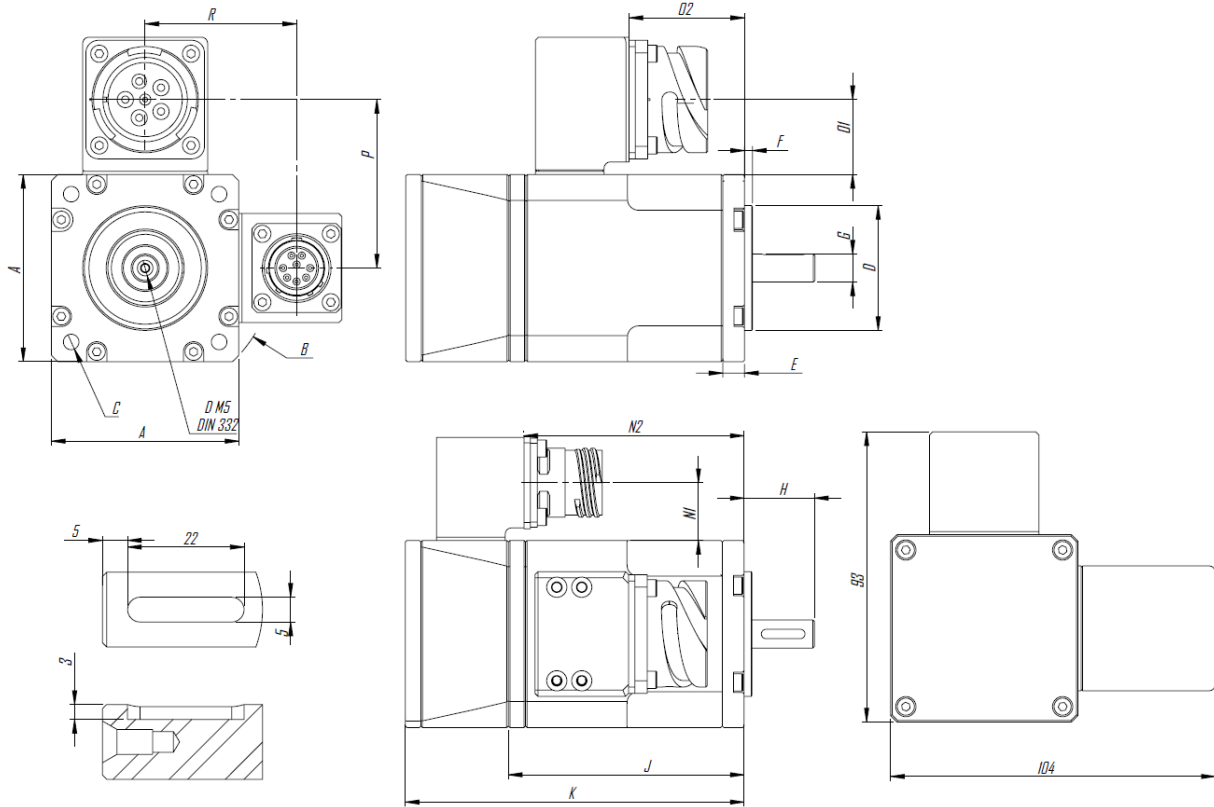

Symbols	Units	Frensiz			Frenli		
		LVSM-070-01	LVSM-070-02	LVSM-070-03	LVSM-070-01	LVSM-070-02	LVSM-070-03
A	mm	70	70	70	70	70	70
B	mm	Ø94	Ø94	Ø94	Ø94	Ø94	Ø94
C	mm	Ø 6 on Ø75	Ø 6 on Ø75	Ø 6 on Ø75	Ø 6 on Ø75	Ø 6 on Ø75	Ø 6 on Ø75
D	mm	Ø60	Ø60	Ø60	Ø60	Ø60	Ø60
E	mm	7	7	7	7	7	7
F	mm	2.5	2.5	2.5	2.5	2.5	2.5
G	mm	Ø14	Ø14	Ø14	Ø14	Ø14	Ø14
J	mm	84	118	151	84	118	151
K	mm	115	149	181	150	184	216
L	mm	103	103	103	103	103	103
M	mm	115	115	115	115	115	115
N1	mm	19	19	19	19	19	19
N2	mm	78	112	145	115	149	182
O1	mm	25	25	25	25	25	25
O2	mm	38	72	104	38	72	104
P	mm	60	60	60	60	60	60
R	mm	54	54	54	54	54	54

Power - Signal Connector

Power Connector (CB2-20-22-PC-FM)

Pin	Function	Description
A	A	Phase A
B	-	-
C	C	Phase C
D	-	-
E	B	Phase B
F	GND	GND

Signal Connector (D38999/20WC8PN)

Pin	Function	Description
A	R1	Ref (+)
B	R2	Ref (-)
C	S1	Cos (+)
D	S3	Cos (-)
E	S2	Sin (+)
F	S4	Sin (-)
G	NTC	Thermal Sensor
H	NTC	Thermal Sensor

LVSM-080 Technical Information

	Motor Parameters	Symbols	Units	LVSM-080-01				LVSM-080-02				LVSM-080-03			
				Winding Type		A		B		A		B		A	
PERFORMANCE	DC Bus Voltage	V _{dc}	V	24	48	24	48	24	48	24	48	24	48	24	48
	Rated Power	P _r	W	0.41	0.87	0.52	1.02	0.54	1.13	0.79	1.55	0.72	1.46	0.91	1.75
	Stall Torque	T _s	Nm	1.58	1.58	1.53	1.53	2.92	2.92	2.88	2.88	4.07	4.07	3.94	3.94
	Rated Torque	T _r	Nm	1.51	1.46	1.46	1.36	2.80	2.66	2.76	2.55	3.90	3.62	3.76	3.39
	Peak Torque	T _p	Nm	4.29	4.29	4.29	4.29	8.59	8.59	8.57	8.57	12.9	12.9	12.9	12.9
	Rated Speed	N _r	rpm	2625	5675	3400	7200	1850	4075	2750	5800	1775	3850	2300	4925
	No-Load Speed ⁽²⁾	N _{no-load}	rpm	3478	6957	4348	8696	2484	4969	3478	6957	2308	4615	2899	5797
	Torque Constant	K _t	Nm/A _{rms}	0.08	0.08	0.06	0.06	0.11	0.11	0.08	0.08	0.12	0.12	0.10	0.10
	Voltage Constant ⁽²⁾	K _v	V _{rms} /krpm	4.88	4.88	3.90	3.90	6.83	6.83	4.88	4.88	7.35	7.35	5.85	5.85
ELECTRICAL	Stall Current	I _s	A _{rms}	19.6	19.6	23.9	23.9	26.0	26.0	35.8	35.8	33.6	33.6	40.6	40.6
	Rated Current	I _r	A _{rms}	19.0	18.3	23.2	21.7	25.2	24.0	34.7	32.3	32.6	30.5	39.4	35.8
	Peak Current	I _p	A _{rms}	56.0	56.0	70.0	70.0	80.0	80.0	112	112	112	112	140	140
	Line Resistance ⁽²⁾	R _{LL}	mOhm	86 (±20%)	86 (±20%)	56 (±20%)	56 (±20%)	69 (±20%)	69 (±20%)	35 (±20%)	35 (±20%)	48 (±20%)	48 (±20%)	30 (±20%)	30 (±20%)
	Line Inductance ⁽²⁾	L _{LL}	mH	0.18 (±30%)	0.18 (±30%)	0.12 (±30%)	0.12 (±30%)	0.17 (±30%)	0.17 (±30%)	0.09 (±30%)	0.09 (±30%)	0.13 (±30%)	0.13 (±30%)	0.08 (±30%)	0.08 (±30%)
	Inertia (without brake)	J	kg.cm ²	0.83	0.83	0.83	0.83	1.45	1.45	1.45	1.45	2.05	2.05	2.05	2.05
	Weight (without brake)	W	kg	3.39	3.39	3.38	3.38	4.19	4.19	4.19	4.19	5.00	5.01	5.01	5.02
	Thermal Resistance ⁽²⁾	K _{therm}	C°/W	1.97	1.62	1.92	1.47	1.42	1.26	1.36	1.14	1.20	1.06	1.24	1.02
	Mech. Time Constant	K _{mech}	ms	1.35	1.32	1.36	1.36	0.96	0.96	0.96	0.96	0.82	0.82	0.80	0.79
	Motor Constant	K _m	Nm/VW	0.23	0.24	0.23	0.24	0.36	0.38	0.36	0.39	0.47	0.50	0.47	0.52
FEEDBACK	Pole Number	n		10											
	Input Voltage	V _{rms}		5											
	Frequency	kHz		4.5											
	Input Current	mA		58											
	Transformation Ratio			0.5±10%											
	Null Voltage	mV _{max}		30											
	Phase Shift	Deg		-15°±2°											

1. All performance and electrical specifications are obtained at 25°C ambient and may change ±10%. 2. Rated data with reference aluminum plate 250mm x 250mm x 6mm (maximum winding temperature is 120°C). 3. Higher torque and speed values as well as dimensions on request.

LVSM-080 Torque-Speed Curves

Tr: Rated Torque — @Tr 24V - - - @Tr 48V
 Tp: Peak Torque — @Tp 24V - - - @Tp 48V

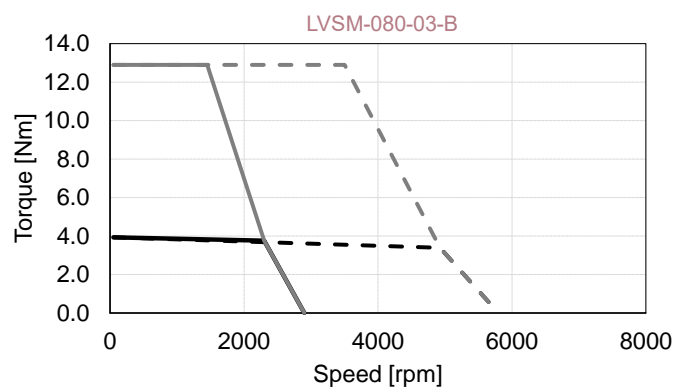
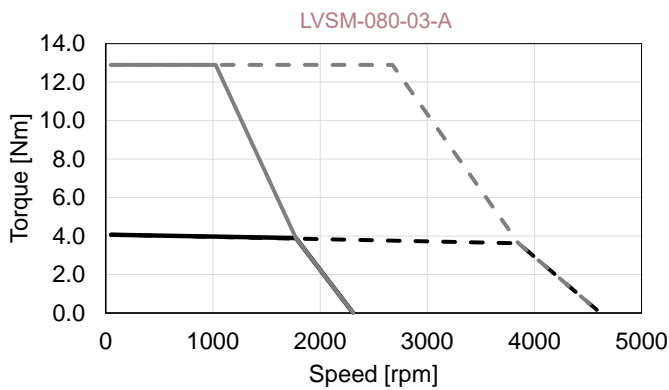
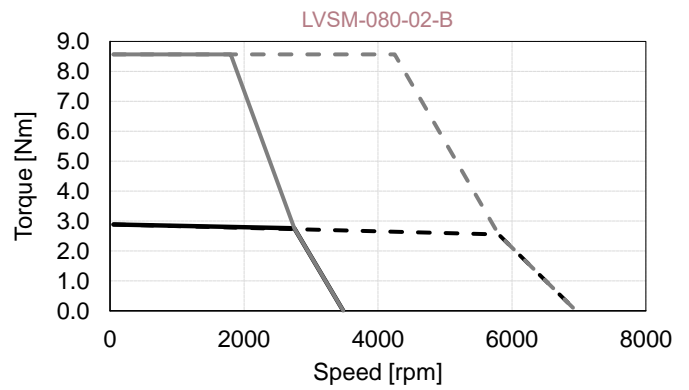
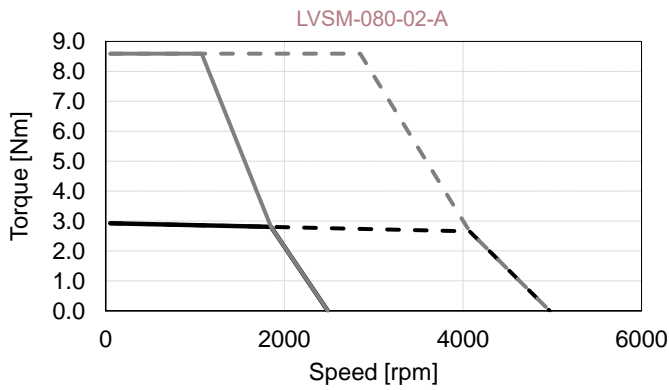
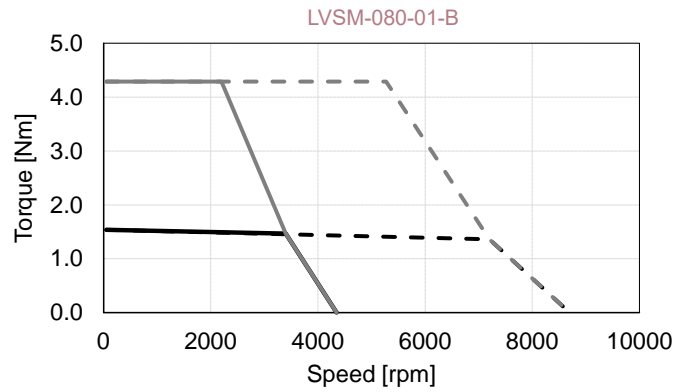
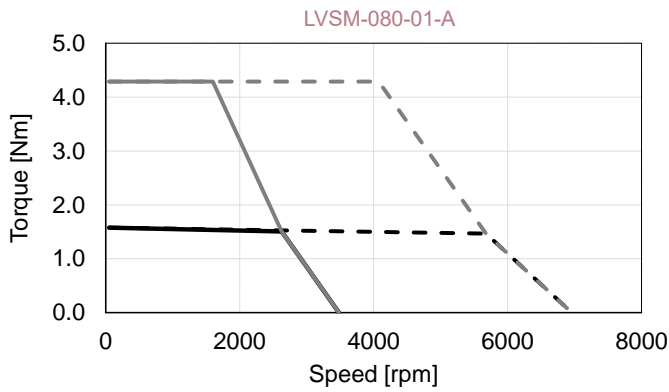

LVSM-080 Outline Drawing

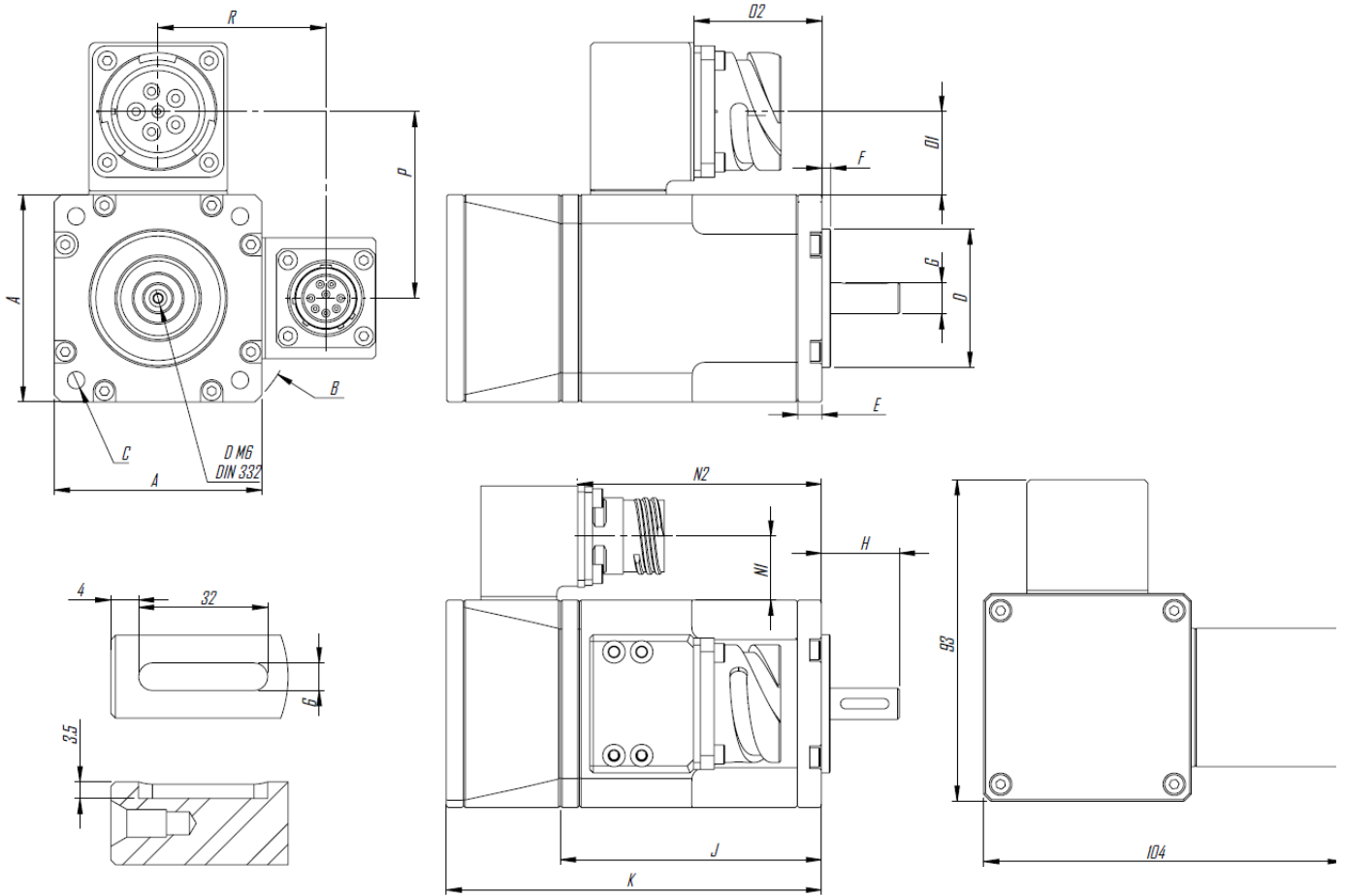

Symbols	Units	Frensiz			Frenli		
		LVSM-080-01	LVSM-080-02	LVSM-080-03	LVSM-080-01	LVSM-080-02	LVSM-080-03
A	mm	80	80	80	80	80	80
B	mm	Ø108	Ø108	Ø108	Ø108	Ø108	Ø108
C	mm	Ø 7 on Ø90	Ø 7 on Ø90	Ø 7 on Ø90	Ø 7 on Ø90	Ø 7 on Ø90	Ø 7 on Ø90
D	mm	Ø60	Ø60	Ø60	Ø60	Ø60	Ø60
E	mm	8	8	8	8	8	8
F	mm	3	3	3	3	3	3
G	mm	Ø19	Ø19	Ø19	Ø19	Ø19	Ø19
J	mm	81	106	131	81	106	131
K	mm	113	138	163	151	176	201
L	mm	113	113	113	113	113	113
M	mm	126	126	126	126	126	126
N1	mm	19	19	19	19	19	19
N2	mm	76	101	126	114	139	164
O1	mm	25	25	25	25	25	25
O2	mm	41	66	91	41	66	91
P	mm	65	65	65	65	65	65
R	mm	59	59	59	59	59	59

Power - Signal Connector

Power Connector (CB2-20-22-PC-FM)

Pin	Function	Description
A	A	Phase A
B	-	-
C	C	Phase C
D	-	-
E	B	Phase B
F	GND	GND

Signal Connector (D38999/20WC8PN)

Pin	Function	Description
A	R1	Ref (+)
B	R2	Ref (-)
C	S1	Cos (+)
D	S3	Cos (-)
E	S2	Sin (+)
F	S4	Sin (-)
G	NTC	Thermal Sensor
H	NTC	Thermal Sensor

LVSM-090 Technical Information

	Motor Parameters	Symbols	Units	LVSM-090-01				LVSM-090-02				LVSM-090-03			
				Winding Type		A		B		A		B		A	
PERFORMANCE	DC Bus Voltage	V _{dc}	V	24	48	24	48	24	48	24	48	24	48	24	48
	Rated Power	P _r	W	0.73	1.40	1.09	1.81	0.97	1.86	1.30	2.24	1.38	2.54	1.74	2.71
	Stall Torque	T _s	Nm	3.00	3.00	2.92	2.92	5.35	5.35	5.19	5.19	7.05	7.05	6.91	6.91
	Rated Torque	T _r	Nm	2.83	2.56	2.72	2.13	5.02	4.49	4.86	3.96	6.59	5.64	6.46	4.75
	Peak Torque	T _p	Nm	8.64	8.64	8.64	8.64	17.3	17.3	17.3	17.3	25.9	25.9	25.9	25.9
	Rated Speed	N _r	rpm	2450	5225	3825	8100	1850	3950	2550	5400	2000	4300	2575	5450
	No-Load Speed ⁽²⁾	N _{no-load}	rpm	3109	6218	4660	9320	2330	4660	3109	6218	2487	4974	3109	6218
	Torque Constant	K _t	Nm/ A _{rms}	0.09	0.09	0.06	0.06	0.12	0.12	0.09	0.09	0.11	0.11	0.09	0.09
	Voltage Constant ⁽²⁾	K _v	V _{rms} /krpm	5.46	5.46	3.64	3.64	7.28	7.28	5.46	5.46	6.82	6.82	5.46	5.46
ELECTRICAL	Stall Current	I _s	A _{rms}	33.3	33.3	48.5	48.5	44.5	44.5	57.6	57.6	62.5	62.5	76.6	76.6
	Rated Current	I _r	A _{rms}	32.0	29.2	46.2	37.0	42.4	38.2	54.9	45.3	59.5	51.4	73.0	54.6
	Peak Current	I _p	A _{rms}	101	101	152	152	152	152	202	202	242	242	303	303
	Line Resistance ⁽²⁾	R _{LL}	mOhm	32 (±20%)	32 (±20%)	14 (±20%)	14 (±20%)	23 (±20%)	23 (±20%)	13 (±20%)	13 (±20%)	13 (±20%)	13 (±20%)	8 (±20%)	8 (±20%)
	Line Inductance ⁽²⁾	L _{LL}	mH	0.18 (±30%)	0.18 (±30%)	0.12 (±30%)	0.12 (±30%)	0.17 (±30%)	0.17 (±30%)	0.09 (±30%)	0.09 (±30%)	0.13 (±30%)	0.13 (±30%)	0.08 (±30%)	0.08 (±30%)
	Inertia (without brake)	J	kg.cm ²	2.0	2.0	2.0	2.0	3.7	3.7	3.7	3.7	5.4	5.4	5.4	5.4
	Weight (without brake)	W	kg	3.59	3.61	3.61	3.61	5.30	5.30	5.30	5.30	6.97	6.97	6.99	6.99
	Thermal Resistance ⁽²⁾	K _{therm}	C°/W	1.80	1.37	1.59	1.00	1.42	1.13	1.32	0.94	1.18	0.87	1.09	0.75
	Mech. Time Constant	K _{mech}	ms	0.96	0.96	0.96	0.96	0.72	0.72	0.72	0.72	0.67	0.66	0.66	0.66
	Motor Constant	K _m	Nm/vW	0.43	0.47	0.43	0.54	0.68	0.75	0.68	0.82	0.85	0.99	0.86	1.15
	Pole Number	n		10											
FEEDBACK	Input Voltage		V _{rms}	5											
	Frequency		kHz	4.5											
	Input Current		mA	58											
	Transformation Ratio			0.5±10%											
	Null Voltage		mV _{max}	30											
	Phase Shift		Deg	-15°±2°											

1. All performance and electrical specifications are obtained at 25°C ambient and may change ±10%. 2. Rated data with reference aluminum plate 250mm x 250mm x 6mm (maximum winding temperature is 120°C). 3. Higher torque and speed values as well as dimensions on request.

LVSM-090 Torque-Speed Curves

Tr: Rated Torque @Tr 24V --- @Tr 48V
 Tp: Peak Torque @Tp 24V - - - @Tp 48V

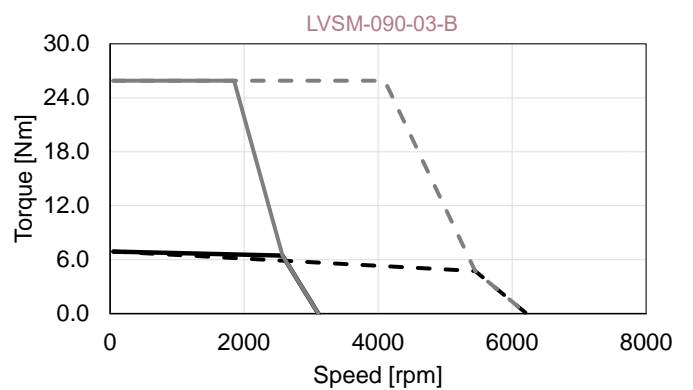
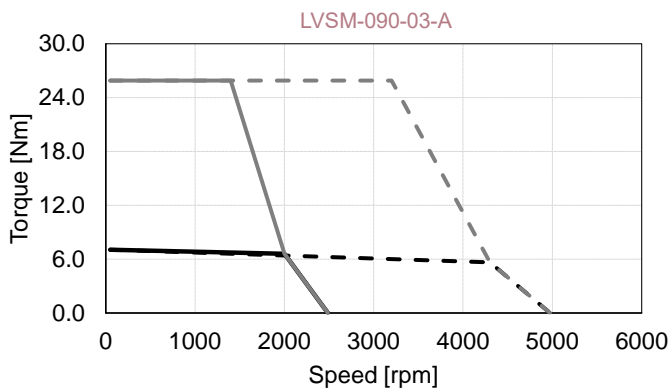
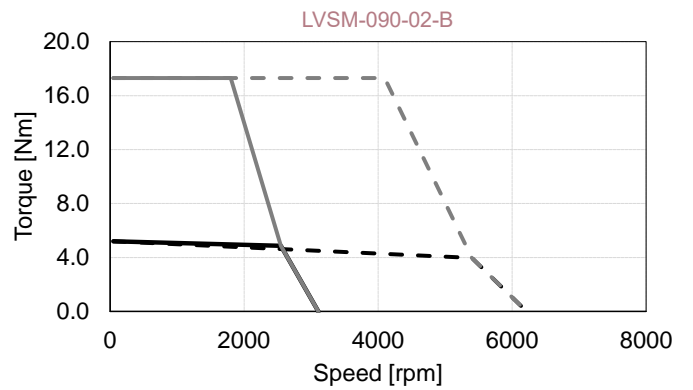
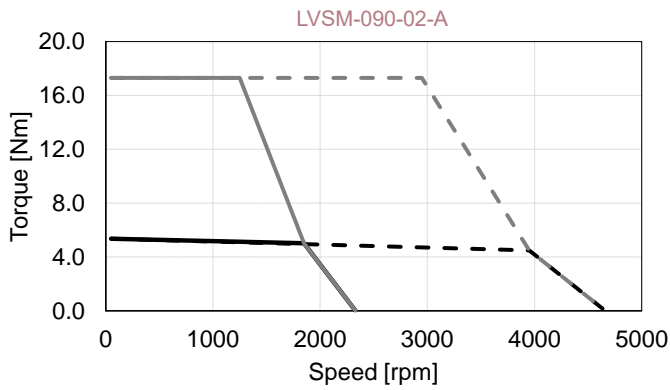
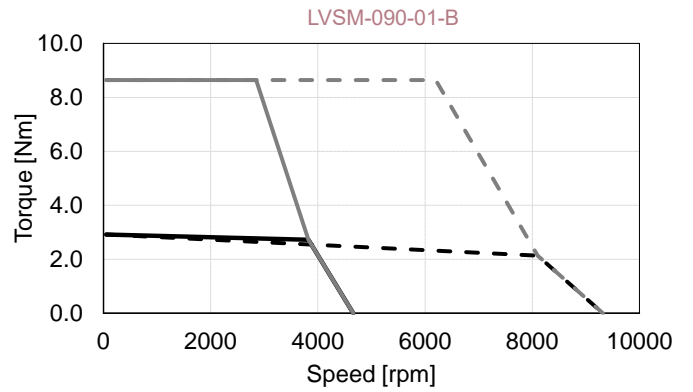
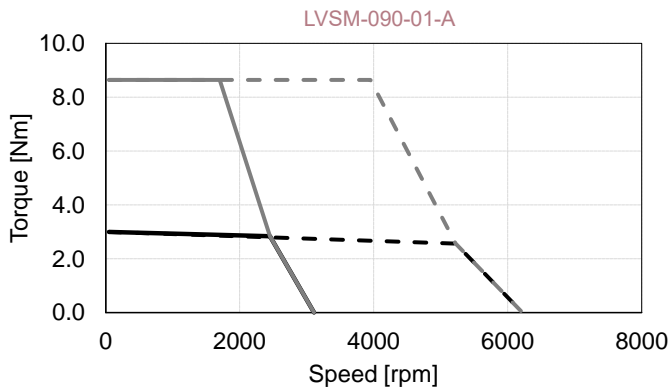

LVSM-090 Outline Drawing

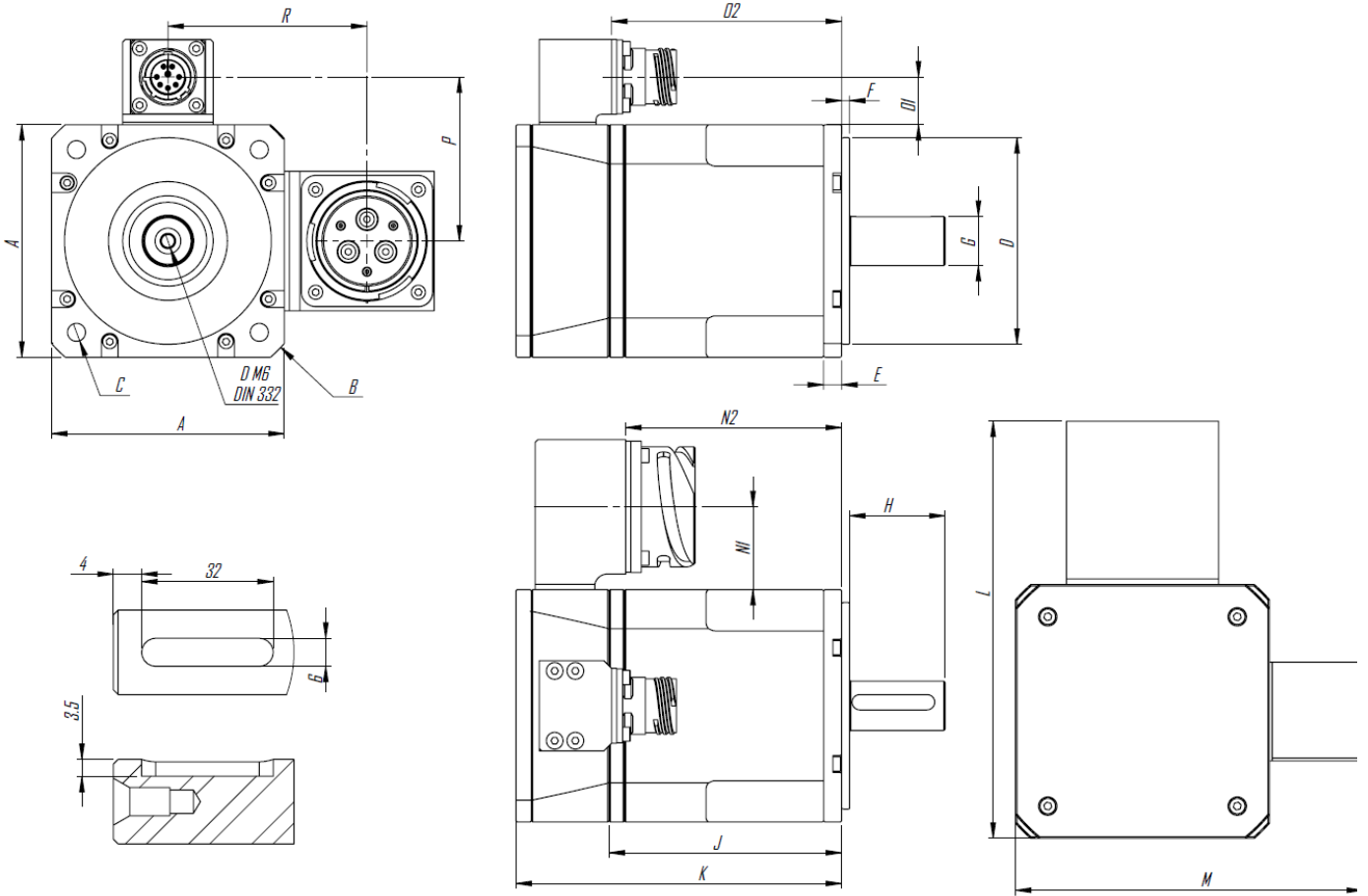

Symbols	Units	Frensiz			Frenli		
		LVSM-090-01	LVSM-090-02	LVSM-090-03	LVSM-090-01	LVSM-090-02	LVSM-090-03
A	mm	90	90	90	90	90	90
B	mm	Ø120	Ø120	Ø120	Ø120	Ø120	Ø120
C	mm	Ø 7 on Ø100	Ø 7 on Ø100	Ø 7 on Ø100	Ø 7 on Ø100	Ø 7 on Ø100	Ø 7 on Ø100
D	mm	Ø80	Ø80	Ø80	Ø80	Ø80	Ø80
E	mm	7	7	7	7	7	7
F	mm	3	3	3	3	3	3
G	mm	Ø 19	Ø 19	Ø 19	Ø 19	Ø 19	Ø 19
J	mm	90	130	170	90	130	170
K	mm	161	201	241	161	201	241
L	mm	123	123	123	123	123	123
M	mm	148	148	148	148	148	148
N1	mm	32	32	32	32	32	32
N2	mm	84	129	169	119	159	199
O1	mm	19	19	19	19	19	19
O2	mm	89	124	164	124	164	204
P	mm	64	64	64	64	64	64
R	mm	77	77	77	77	77	77

Power - Signal Connector

Power Connector (CB2-28-22-PC-FM)

Pin	Function	Description
A	A	Phase A
B	B	Phase B
C	C	Phase C
D	-	-
E	-	-
F	GND	GND

Signal Connector (D38999/20WC8PN)

Pin	Function	Description
A	R1	Ref (+)
B	R2	Ref (-)
C	S1	Cos (+)
D	S3	Cos (-)
E	S2	Sin (+)
F	S4	Sin (-)
G	NTC	Thermal Sensor
H	NTC	Thermal Sensor

LVSM-100 Technical Information

Motor Parameters			LVSM-100-01				LVSM-100-02				LVSM-100-03				
Winding Type	Symbols	Units	A		B		A		B		A		B		
PERFORMANCE	DC Bus Voltage	V _{dc}	24	48	24	48	24	48	24	48	24	48	24	48	
	Rated Power	P _r	0.54	1.12	0.73	1.45	0.95	1.88	1.36	2.54	1.45	2.76	1.76	3.14	
	Stall Torque	T _s	2.72	2.72	2.79	2.79	5.10	5.10	4.99	4.99	6.80	6.80	6.76	6.76	
	Rated Torque	T _r	2.63	2.55	2.67	2.52	4.89	4.59	4.76	4.26	6.51	5.92	6.45	5.56	
	Peak Torque	T _p	7.96	7.96	7.97	7.97	15.9	15.9	15.9	15.9	23.9	23.9	23.9	23.9	
	Rated Speed	N _r	rpm	1950	4200	2600	5500	1850	3900	2725	5700	2125	4450	2600	5400
	No-Load Speed ⁽²⁾	N _{no-load}	rpm	2589	5178	3329	6657	2330	4660	3329	6657	2589	5178	3105	6210
	Torque Constant	K _t	Nm/ A _{rms}	0.11	0.11	0.08	0.08	0.12	0.12	0.08	0.08	0.11	0.11	0.09	0.09
	Voltage Constant ⁽²⁾	K _v	V _{rms} /krpm	6.55	6.55	5.10	5.10	7.28	7.28	5.10	5.10	6.55	6.55	5.47	5.47
	ELECTRICAL	Stall Current	I _s	25.2	25.2	33.1	33.1	42.4	42.4	59.2	59.2	62.6	62.6	74.7	74.7
Rated Current		I _r	24.7	24.0	32.2	30.7	41.1	38.9	57.5	51.9	60.8	55.7	72.5	63.3	
Peak Current		I _p	75.9	75.9	97.7	97.7	137	137	195	195	228	228	273	273	
Line Resistance ⁽²⁾		R _{LL}	mOhm	56.0 (±20%)	55.6 (±20%)	33.2 (±20%)	33.2 (±20%)	27.2 (±20%)	27.2 (±20%)	12.4 (±20%)	12.4 (±20%)	12.6 (±20%)	12.6 (±20%)	8.80 (±20%)	8.80 (±20%)
Line Inductance ⁽²⁾		L _{LL}	mH	0.20 (±30%)	0.20 (±30%)	0.12 (±30%)	0.12 (±30%)	0.12 (±30%)	0.12 (±30%)	0.06 (±30%)	0.06 (±30%)	0.06 (±30%)	0.06 (±30%)	0.04 (±30%)	0.04 (±30%)
Inertia (without brake)		J	kg.cm ²	2.15	2.15	2.15	2.15	3.9	3.9	3.9	3.9	5.65	5.65	5.65	5.65
Weight (without brake)		W	kg	3.81	3.79	3.79	3.79	5.43	5.43	5.42	5.42	7.06	7.06	7.08	7.08
Thermal Resistance ⁽²⁾		K _{therm}	C°/W	1.60	1.31	1.49	1.10	1.15	0.92	1.11	0.78	1.04	0.78	0.94	0.64
Mech. Time Constant		K _{mech}	ms	1.26	1.24	1.23	1.23	0.90	0.89	0.83	0.83	0.74	0.74	0.74	0.74
Motor Constant		K _m	Nm/VW	0.38	0.39	0.39	0.41	0.61	0.65	0.64	0.70	0.81	0.89	0.81	0.93
FEEDBACK	Pole Number	n	10												
	Input Voltage	V _{rms}	5												
	Frequency	kHz	4.5												
	Input Current	mA	58												
	Transformation Ratio		0.5±10%												
	Null Voltage	mV _{max}	30												
	Phase Shift	Deg	-15°±2°												

1. All performance and electrical specifications are obtained at 25°C ambient and may change ±10%. 2. Rated data with reference aluminum plate 300mm x 300mm x 12mm (maximum winding temperature is 120°C). 3. Higher torque and speed values as well as dimensions on request.

LVSM-100 Torque-Speed Curves

Tr: Rated Torque — @Tr 24V - - - @Tr 48V
 Tp: Peak Torque — @Tp 24V - - - @Tp 48V

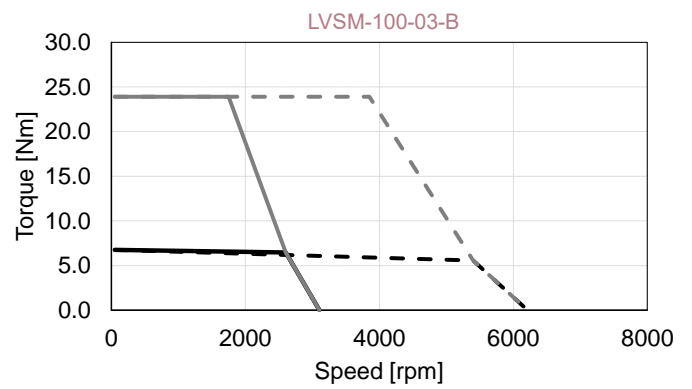
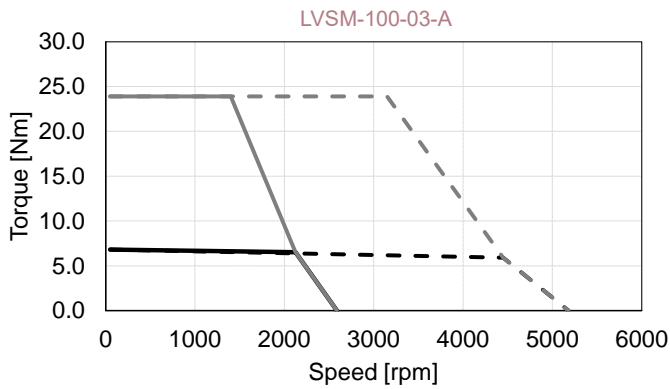
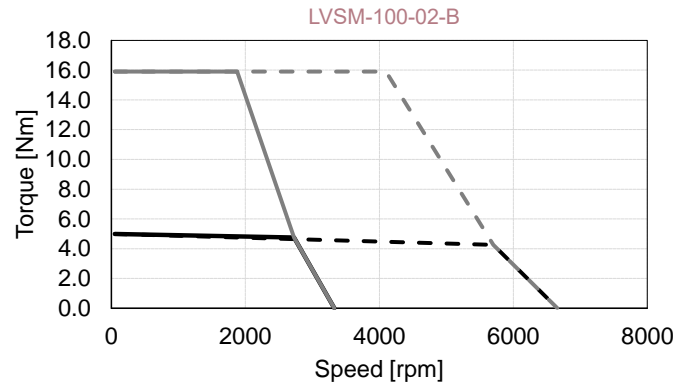
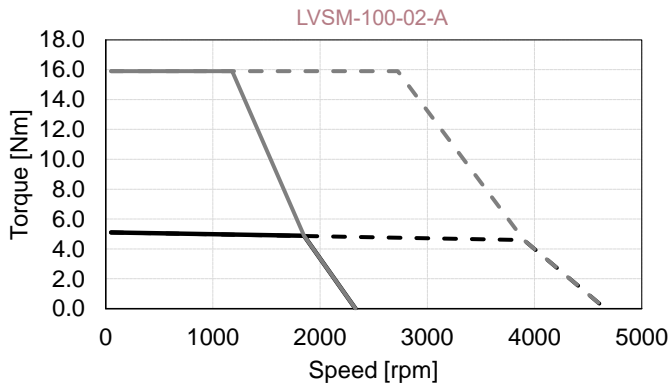
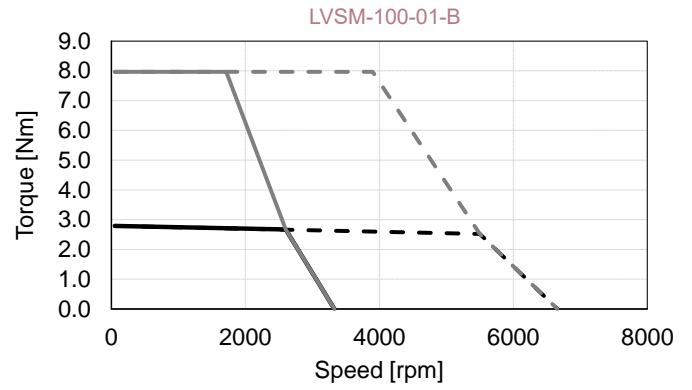
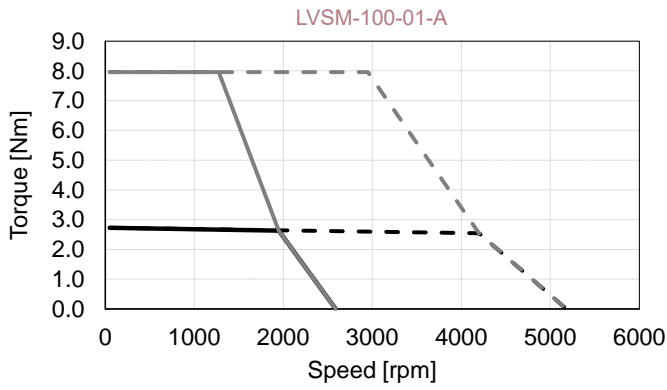

LVSM-100 Outline Drawing

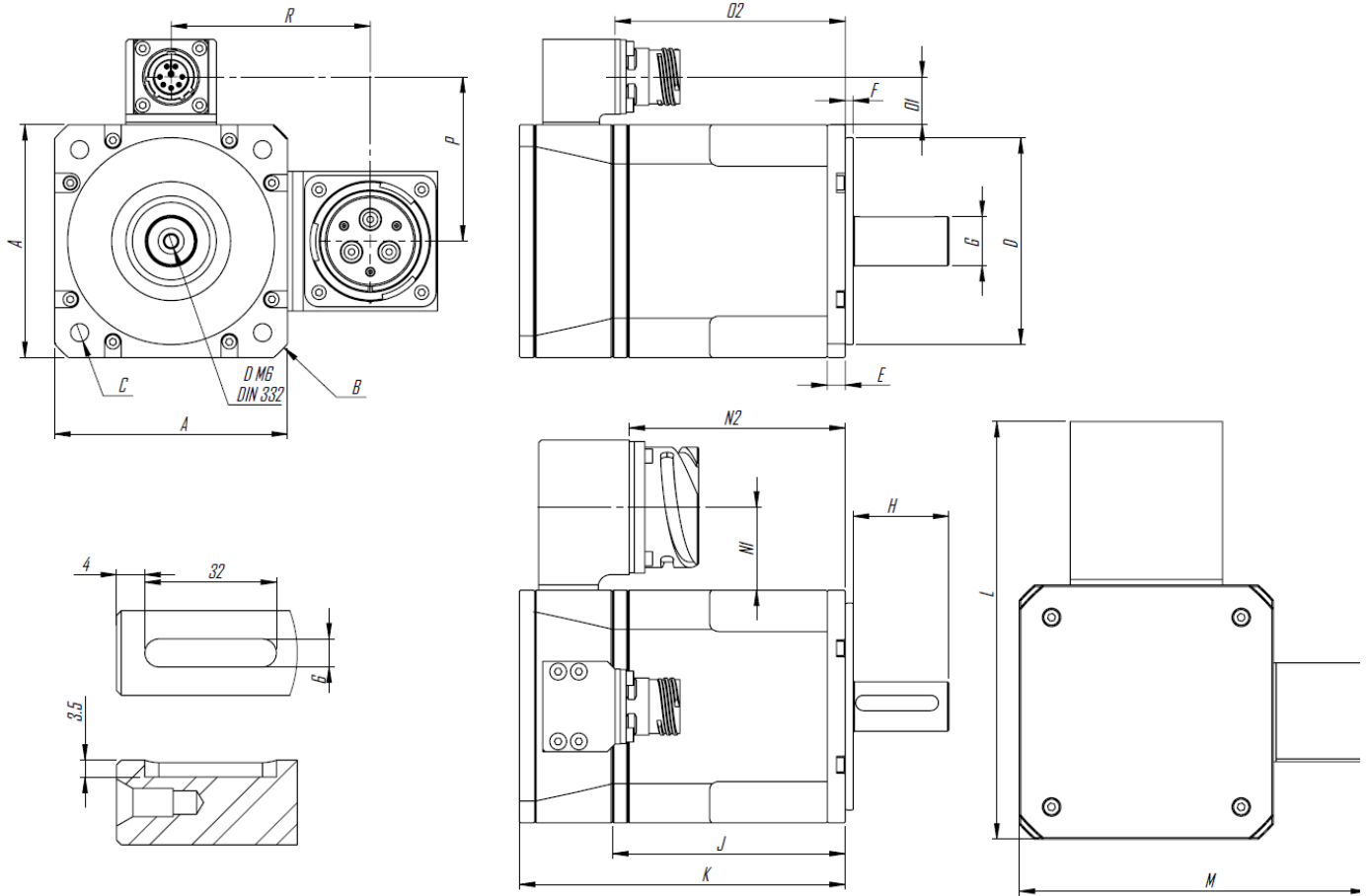

Symbols	Units	Frensiz			Frenli		
		LVSM-100-01	LVSM-100-02	LVSM-100-03	LVSM-100-01	LVSM-100-02	LVSM-100-03
A	mm	100	100	100	100	100	100
B	mm	Ø134	Ø134	Ø134	Ø134	Ø134	Ø134
C	mm	Ø9 on Ø115	Ø9 on Ø115	Ø9 on Ø115	Ø9 on Ø115	Ø9 on Ø115	Ø9 on Ø115
D	mm	Ø95	Ø95	Ø95	Ø95	Ø95	Ø95
E	mm	10	10	10	10	10	10
F	mm	3	3	3	3	3	3
G	mm	Ø24	Ø24	Ø24	Ø24	Ø24	Ø24
J	mm	82	112	142	82	112	142
K	mm	114	144	174	156	186	216
L	mm	157	157	157	157	157	157
M	mm	133	133	133	133	133	133
N1	mm	31	31	31	31	31	31
N2	mm	72	102	132	114	144	174
O1	mm	19	19	19	19	19	19
O2	mm	75	105	135	117	147	177
P	mm	69	69	69	69	69	69
R	mm	81	81	81	81	81	81

Power - Signal Connector

Power Connector (CB2-28-22-PC-FM)

Pin	Function	Description
A	A	Phase A
B	B	Phase B
C	C	Phase C
D	-	-
E	-	-
F	GND	GND

Signal Connector (D38999/20WC8PN)

Pin	Function	Description
A	R1	Ref (+)
B	R2	Ref (-)
C	S1	Cos (+)
D	S3	Cos (-)
E	S2	Sin (+)
F	S4	Sin (-)
G	NTC	Thermal Sensor
H	NTC	Thermal Sensor

LVSM-115 Technical Information

	Motor Parameters	Symbols	Units	LVSM-115-01				LVSM-115-02				LVSM-115-03			
				Winding Type		A		B		A		B		A	
PERFORMANCE	DC Bus Voltage	V _{dc}	V	24	48	24	48	24	48	24	48	24	48	24	48
	Rated Power	P _r	W	1.12	2.13	1.37	2.46	1.64	2.92	2.39	3.66	2.16	3.73	2.81	3.80
	Stall Torque	T _s	Nm	5.06	5.06	4.94	4.94	8.7	8.7	8.3	8.32	11.3	11.3	11.0	11.0
	Rated Torque	T _r	Nm	4.74	4.35	4.60	3.96	8.1	7.0	7.7	5.78	10.6	8.9	10.2	6.7
	Peak Torque	T _p	Nm	15.4	15.4	15.4	15.4	30.8	30.8	30.8	30.8	46.2	46.2	46.1	46.2
	Rated Speed	N _r	rpm	2250	4675	2850	5925	1925	3975	2950	6050	1950	4000	2625	5400
	No-Load Speed ⁽²⁾	N _{no-load}	rpm	2700	5399	3376	6751	2243	4486	3376	6751	2243	4486	3000	6000
	Torque Constant	K _t	Nm/ A _{rms}	0.10	0.10	0.08	0.08	0.12	0.12	0.08	0.08	0.13	0.12	0.09	0.09
	Voltage Constant ⁽²⁾	K _v	V _{rms} /krpm	6.29	6.29	5.03	5.03	7.57	7.57	5.03	5.03	7.57	7.57	5.66	5.66
ELECTRICAL	Stall Current	I _s	A _{rms}	48.7	48.7	59.3	59.3	69.7	69.7	99.5	99.5	90.3	90.3	117.3	117.3
	Rated Current	I _r	A _{rms}	46.4	43.0	56.5	49.4	66.4	58.2	95	73	86	74	112	76
	Peak Current	I _p	A _{rms}	152	152	190	190	254	254	381	381	381	381	507	507
	Line Resistance ⁽²⁾	R _{LL}	mOhm	17 (±20%)	17 (±20%)	11 (±20%)	11 (±20%)	9 (±20%)	9 (±20%)	4 (±20%)	4 (±20%)	5 (±20%)	5 (±20%)	3 (±20%)	3 (±20%)
	Line Inductance ⁽²⁾	L _{LL}	mH	0.07 (±30%)	0.07 (±30%)	0.05 (±30%)	0.05 (±30%)	0.05 (±30%)	0.05 (±30%)	0.02 (±30%)	0.02 (±30%)	0.03 (±30%)	0.03 (±30%)	0.02 (±30%)	0.02 (±30%)
	Inertia (without brake)	J	kg.cm ²	2.15	2.15	2.15	2.15	3.9	3.9	3.9	3.9	5.65	5.65	5.65	5.65
	Weight (without brake)	W	kg	6.31	6.31	6.31	6.31	9.18	9.18	9.18	9.18	12.11	12.11	12.11	12.11
	Thermal Resistance ⁽²⁾	K _{therm}	C°/W	1.30	0.90	1.17	0.71	1.07	0.67	0.87	0.48	0.94	0.53	0.73	0.38
	Mech. Time Constant	K _{mech}	ms	0.40	0.40	0.40	0.40	0.27	0.27	0.27	0.27	0.23	0.23	0.23	0.23
	Motor Constant	K _m	Nm/VW	0.69	0.75	0.69	0.79	1.13	1.29	1.14	1.48	1.47	1.71	1.47	2.17
	Pole Number	n		10											
FEEDBACK	Input Voltage	V _{rms}	4												
	Frequency	kHz	5												
	Input Current	mA	26												
	Transformation Ratio		0.5±10%												
	Null Voltage	mV _{max}	30												
	Phase Shift	Deg	-8°±2°												

1. All performance and electrical specifications are obtained at 25°C ambient and may change ±10%. 2. Rated data with reference aluminum plate 300mm x 300mm x 12mm (maximum winding temperature is 120°C). 3. Higher torque and speed values as well as dimensions on request.

LVSM-115 Torque-Speed Curves

Tr: Rated Torque — @Tr 24V - - - @Tr 48V
 Tp: Peak Torque — @Tp 24V - - - @Tp 48V

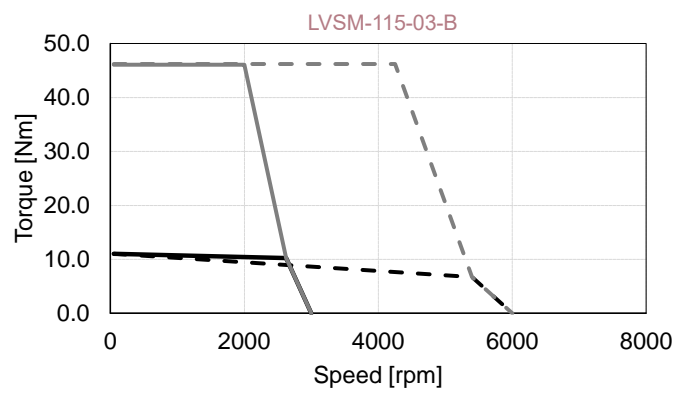
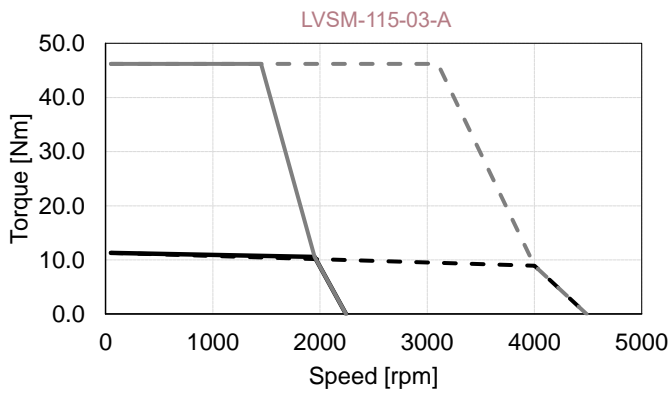
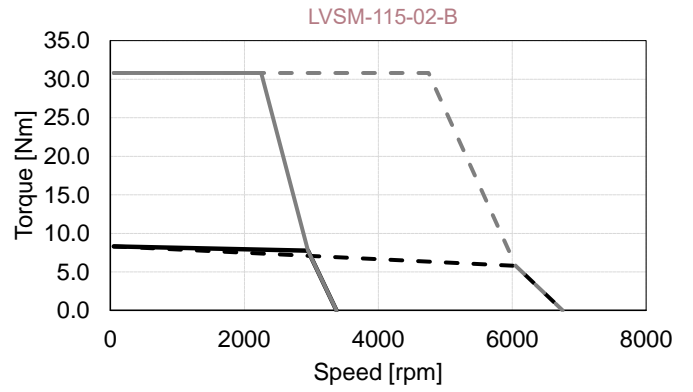
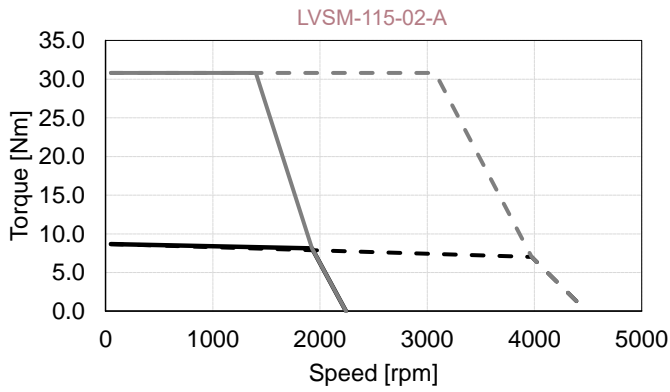
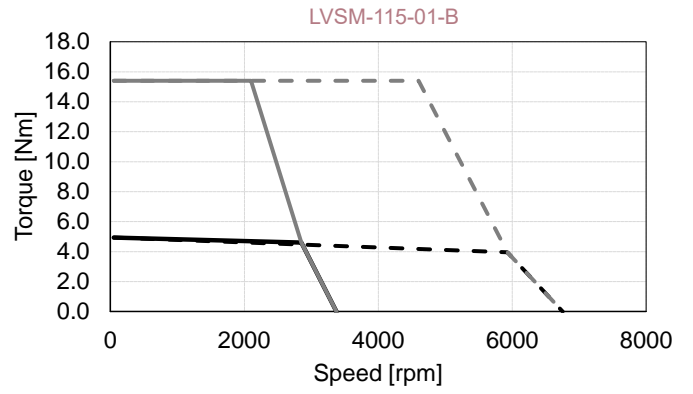
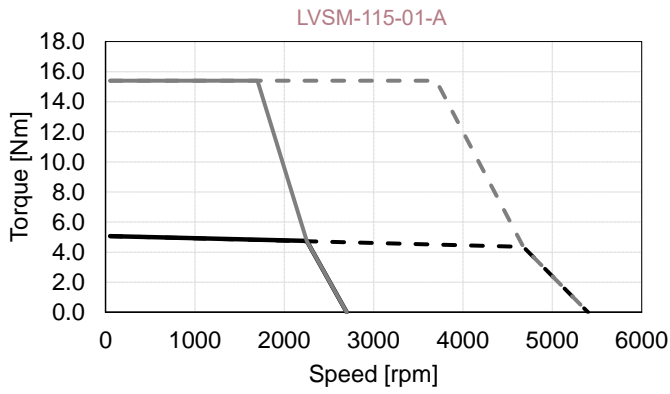

LVSM-115 Outline Drawing

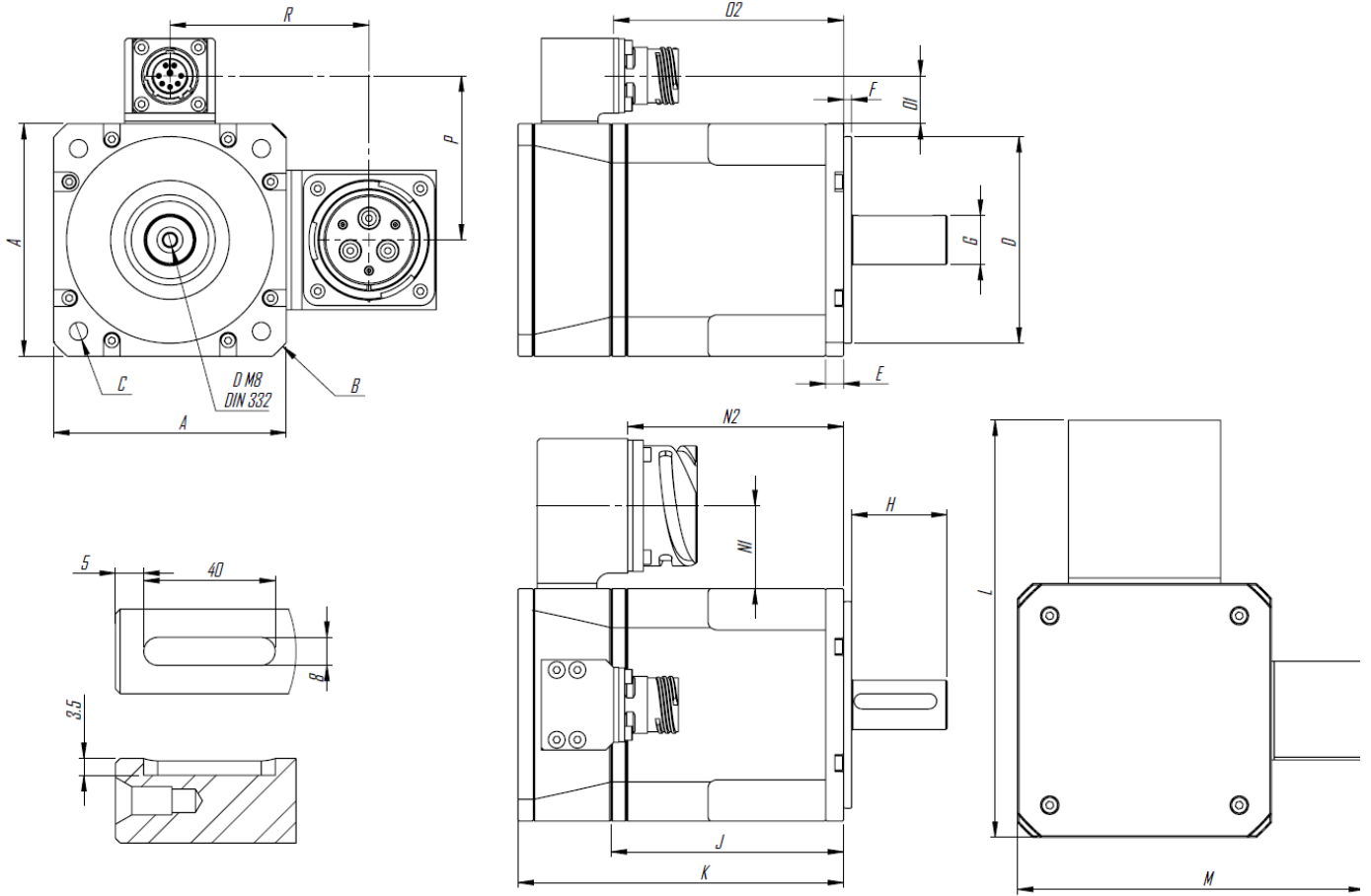

Symbols	Units	Frensiz			Frenli		
		LVSM-115-01	LVSM-115-02	LVSM-115-03	LVSM-115-01	LVSM-115-02	LVSM-115-03
A	mm	115	115	115	115	115	115
B	mm	Ø156	Ø156	Ø156	Ø156	Ø156	Ø156
C	mm	Ø9 on Ø130	Ø9 on Ø130	Ø9 on Ø130	Ø9 on Ø130	Ø9 on Ø130	Ø9 on Ø130
D	mm	Ø95	Ø95	Ø95	Ø95	Ø95	Ø95
E	mm	10	10	10	10	10	10
F	mm	3	3	3	3	3	3
G	mm	Ø24	Ø24	Ø24	Ø24	Ø24	Ø24
J	mm	98	138	178	98	138	178
K	mm	141	181	221	189	229	269
L	mm	187	187	187	187	187	187
M	mm	147	147	147	147	147	147
N1	mm	38	38	38	38	38	38
N2	mm	92	132	172	140	180	220
O1	mm	19	19	19	19	19	19
O2	mm	98	138	178	146	186	226
P	mm	75	75	75	75	75	75
R	mm	96	96	96	96	96	96

Power - Signal Connector

Power Connector (CB2-36-3-PC-FM)

Pin	Function	Description
A	GND	GND
B	B	Phase B
C	-	-
D	C	Phase C
E	-	-
F	A	Phase A

Signal Connector (D38999/20WC8PN)

Pin	Function	Description
A	R1	Ref (+)
B	R2	Ref (-)
C	S1	Cos (+)
D	S3	Cos (-)
E	S2	Sin (+)
F	S4	Sin (-)
G	NTC	Thermal Sensor
H	NTC	Thermal Sensor

LVSM-130 Technical Information

	Motor Parameters	Symbols	Units	LVSM-130-01				LVSM-130-02				LVSM-130-03			
				Winding Type		A		B		A		B		A	
PERFORMANCE	DC Bus Voltage	V _{dc}	V	24	48	24	48	24	48	24	48	24	48	24	48
	Rated Power	P _r	W	0.81	1.65	1.13	2.19	1.52	2.93	2.08	3.77	1.93	3.77	3.21	5.50
	Stall Torque	T _s	Nm	6.08	6.08	5.91	5.91	11.3	11.3	10.8	10.8	15.4	15.4	14.9	14.9
	Rated Torque	T _r	Nm	5.92	5.72	5.67	5.30	10.8	10.0	10.2	8.9	14.5	13.3	13.9	11.4
	Peak Torque	T _p	Nm	20.2	20.2	20.2	20.2	40.4	40.4	40.3	40.3	60.5	60.5	60.5	60.5
	Rated Speed	N _r	rpm	1300	2750	1900	3950	1350	2800	1950	4050	1275	2700	2200	4600
	No-Load Speed ⁽²⁾	N _{no-load}	rpm	1678	3357	2344	4688	1678	3350	2353	4688	1558	3117	2606	5212
	Torque Constant	K _t	Nm/A _{rms}	0.17	0.17	0.12	0.12	0.17	0.17	0.12	0.12	0.18	0.18	0.11	0.11
	Voltage Constant ⁽²⁾	K _v	V _{rms} /krpm	10.1	10.1	7.24	7.24	10.1	10.1	7.21	7.24	10.9	10.9	6.51	6.51
ELECTRICAL	Stall Current	I _s	A _{rms}	36.7	36.7	49.9	49.9	67.9	67.9	90.7	90.7	86.7	86.7	139.7	139.7
	Rated Current	I _r	A _{rms}	36.2	35.2	48.7	46.0	65.6	61.6	87.3	77.0	82.6	76.3	133.0	109.9
	Peak Current	I _p	A _{rms}	129	129	181	181	259	259	362	362	362	362	603	603
	Line Resistance ⁽²⁾	R _{LL}	mOhm	32.7 (±20%)	32.7 (±20%)	17.5 (±20%)	17.5 (±20%)	11.88 (±20%)	11.88 (±20%)	6.36 (±20%)	6.36 (±20%)	8.08 (±20%)	8.08 (±20%)	2.88 (±20%)	2.88 (±20%)
	Line Inductance ⁽²⁾	L _{LL}	mH	0.20 (±30%)	0.20 (±30%)	0.10 (±30%)	0.10 (±30%)	0.10 (±30%)	0.10 (±30%)	0.05 (±30%)	0.05 (±30%)	0.07 (±30%)	0.07 (±30%)	0.03 (±30%)	0.03 (±30%)
	Inertia (without brake)	J	kg.cm ²	10.8	10.8	10.8	10.8	20.4	20.4	20.4	20.4	30	30	30	30
	Weight (without brake)	W	kg	8.23	8.28	8.28	8.28	12.11	12.11	12.06	12.06	15.96	15.96	15.97	15.97
	Thermal Resistance ⁽²⁾	K _{therm}	C°/W	1.46	1.14	1.34	0.93	1.10	0.83	0.99	0.63	0.97	0.69	0.81	0.50
	Mech. Time Constant	K _{mech}	ms	1.56	1.56	1.63	1.63	1.07	1.07	1.12	1.11	0.93	0.92	0.92	0.92
	Motor Constant	K _m	Nm/VW	0.76	0.78	0.75	0.79	1.29	1.37	1.26	1.43	1.70	1.84	1.71	2.06
FEEDBACK	Pole Number	n	10												
	Input Voltage	V _{rms}	4												
	Frequency	kHz	5												
	Input Current	mA	26												
	Transformation Ratio		0.5±10%												
	Null Voltage	mV _{max}	30												
	Phase Shift	Deg	-8°±2°												

1. All performance and electrical specifications are obtained at 25°C ambient and may change ±10%. 2. Rated data with reference aluminum plate 300mm x 408mm x 12mm (maximum winding temperature is 120°C). 3. Higher torque and speed values as well as dimensions on request.

LVSM-130 Torque-Speed Curves

Tr: Rated Torque — @Tr 24V - - - @Tr 48V
 Tp: Peak Torque — @Tp 24V - - - @Tp 48V

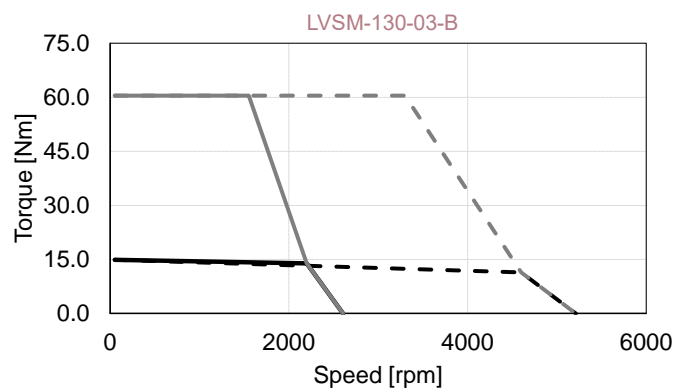
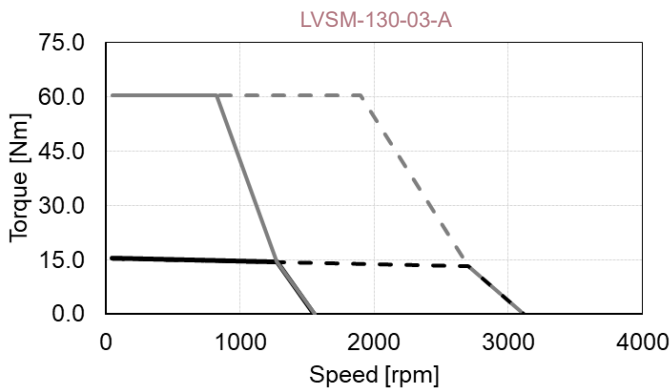
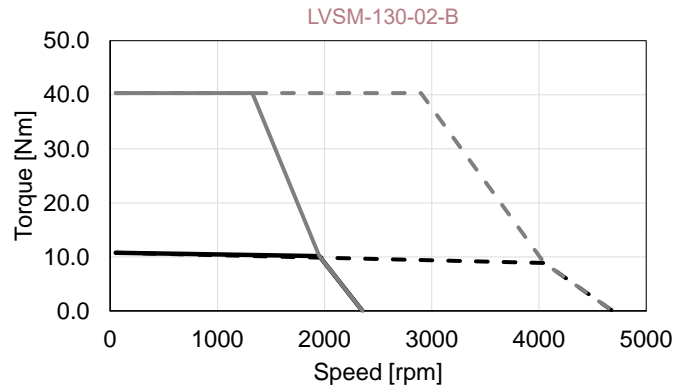
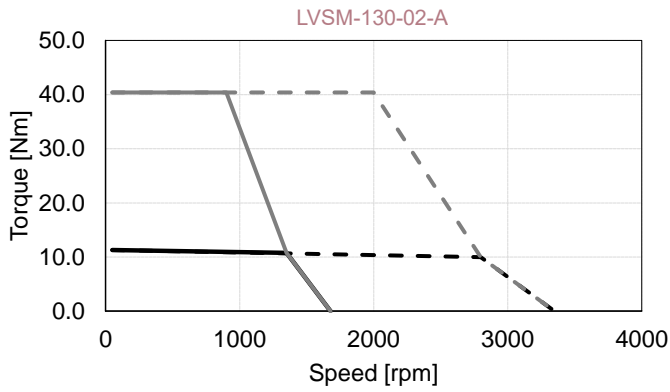
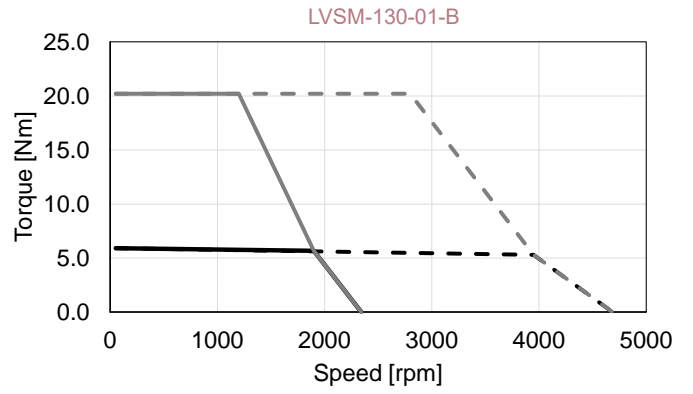
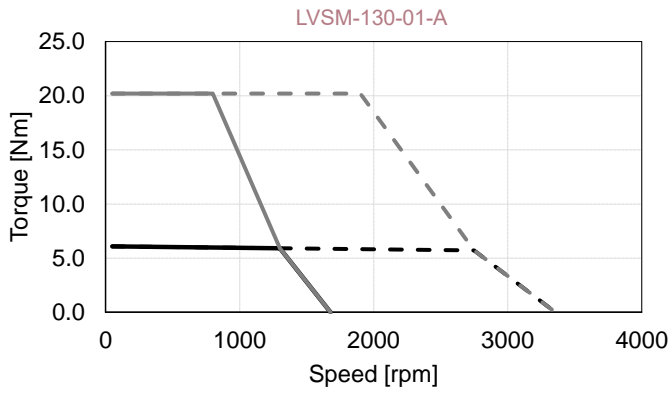

LVSM-130 Outline Drawing

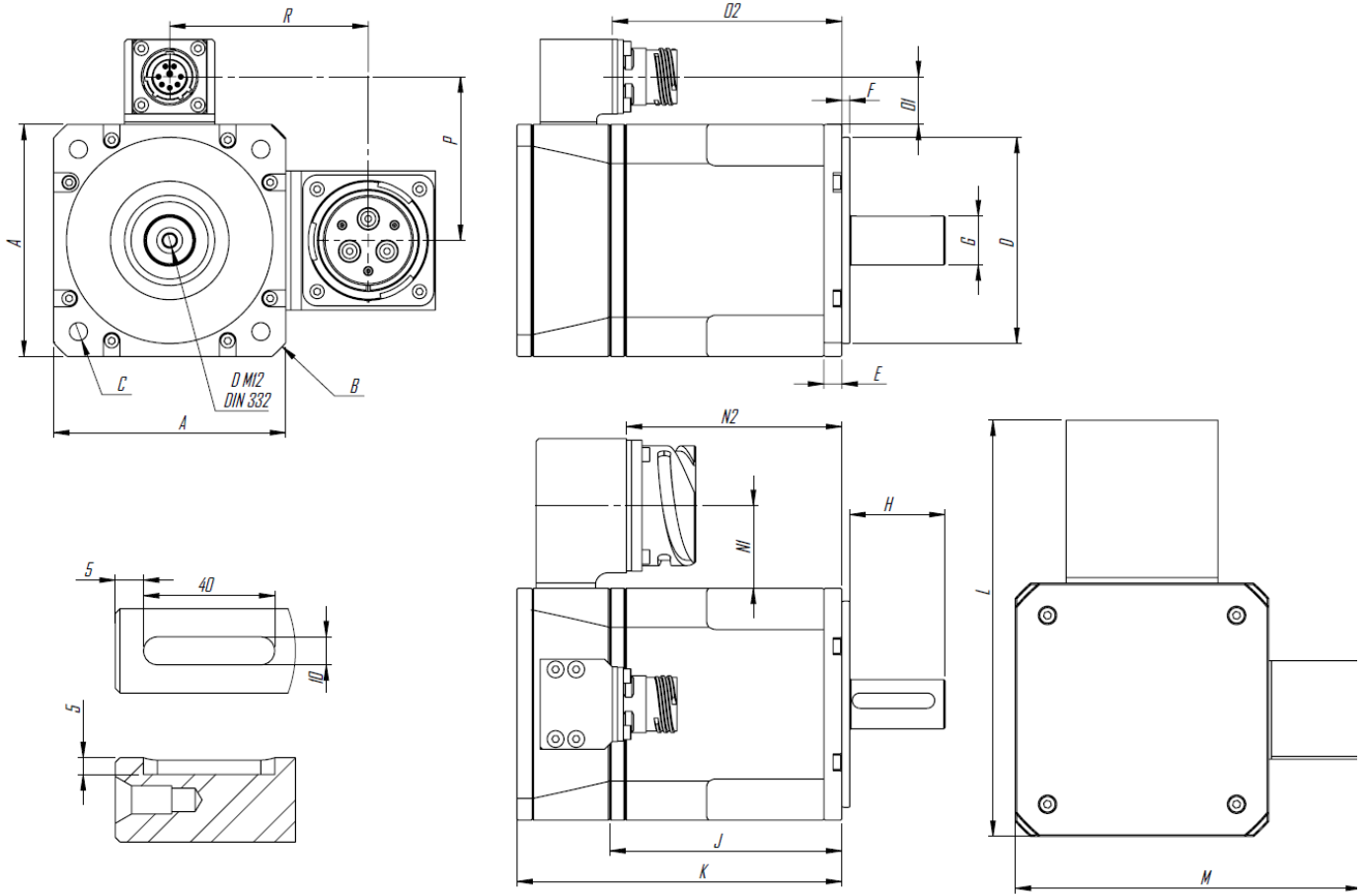

Symbols	Units	Frensiz			Frenli		
		LVSM-130-01	LVSM-130-02	LVSM-130-03	LVSM-130-01	LVSM-130-02	LVSM-130-03
A	mm	130	130	130	130	130	130
B	mm	176	176	176	176	176	176
C	mm	Ø9 on Ø145	Ø9 on Ø145	Ø9 on Ø145	Ø9 on Ø145	Ø9 on Ø145	Ø9 on Ø145
D	mm	Ø110	Ø110	Ø110	Ø110	Ø110	Ø110
E	mm	12	12	12	12	12	12
F	mm	3.5	3.5	3.5	3.5	3.5	3.5
G	mm	Ø32	Ø32	Ø32	Ø32	Ø32	Ø32
J	mm	101	141	181	101	141	181
K	mm	149	189	229	204	244	284
L	mm	201	201	201	201	201	201
M	mm	163	163	163	163	163	163
N1	mm	38	38	38	38	38	38
N2	mm	98	138	178	158	198	238
O1	mm	19	19	19	19	19	19
O2	mm	103	143	183	153	193	233
P	mm	84	84	84	84	84	84
R	mm	103	103	103	103	103	103

Power - Signal Connector

Power Connector (CB2-36-3-PC-FM)

Pin	Function	Description
A	GND	GND
B	B	Phase B
C	-	-
D	C	Phase C
E	-	-
F	A	Phase A

Signal Connector (D38999/20WC8PN)

Pin	Function	Description
A	R1	Ref (+)
B	R2	Ref (-)
C	S1	Cos (+)
D	S3	Cos (-)
E	S2	Sin (+)
F	S4	Sin (-)
G	NTC	Thermal Sensor
H	NTC	Thermal Sensor

	Motor Parameters	Symbols	Units	LVSM-140-01				LVSM-140-02				LVSM-140-03			
				Winding Type		A		B		A		B		A	
PERFORMANCE	DC Bus Voltage	V _{dc}	V	24	48	24	48	24	48	24	48	24	48	24	48
	Rated Power	P _r	W	1.24	2.46	1.69	3.03	2.34	4.05	2.99	4.56	2.85	4.96	4.05	5.24
	Stall Torque	T _s	Nm	7.1	7.1	7.1	7.1	12.8	12.8	12.2	12.2	17.6	17.6	16.4	16.4
	Rated Torque	T _r	Nm	6.7	6.2	6.6	5.7	11.9	10.0	11.3	8.3	16.5	13.6	15.2	9.4
	Peak Torque	T _p	Nm	25.3	25.3	25.3	25.3	50.5	50.5	50.6	50.6	76.0	76.0	75.9	75.9
	Rated Speed	N _r	rpm	1775	3800	2450	5100	1875	3875	2525	5250	1650	3475	2550	5300
	No-Load Speed ⁽²⁾	N _{no-load}	rpm	2214	4428	2952	5904	2214	4444	2952	5904	1967	3934	2952	5904
	Torque Constant	K _t	Nm/A _{rms}	0.13	0.13	0.09	0.09	0.13	0.13	0.09	0.09	0.14	0.14	0.09	0.09
	Voltage Constant ⁽²⁾	K _v	V _{rms} /krpm	7.67	7.67	5.75	5.75	7.67	7.64	5.75	5.75	8.63	8.63	5.75	5.75
	ELECTRICAL	Stall Current	I _s	A _{rms}	56.5	56.5	75.1	75.1	101.0	101.0	128.3	128.3	123.5	123.5	172.7
Rated Current		I _r	A _{rms}	54.4	50.5	71.5	62.4	96.2	81.9	122.2	91.7	117.7	98.8	164.5	105.3
Peak Current		I _p	A _{rms}	209	209	278	278	417	417	557	557	558	558	836	836
Line Resistance ⁽²⁾		R _{LL}	mOhm	16 (±20%)	16 (±20%)	9 (±20%)	9 (±20%)	6 (±20%)	6 (±20%)	3 (±20%)	3 (±20%)	4 (±20%)	4 (±20%)	2 (±20%)	2 (±20%)
Line Inductance ⁽²⁾		L _{LL}	mH	0.06	0.06 (±30%)	0.04 (±30%)	0.04 (±30%)	0.04 (±30%)	0.04 (±30%)	0.02 (±30%)	0.02 (±30%)	0.03 (±30%)	0.03 (±30%)	0.01 (±30%)	0.01 (±30%)
Inertia (without brake)		J	kg.cm ²	19.5	19.5	19.5	19.5	37.5	37.5	37.5	37.5	55.5	55.5	55.5	55.5
Weight (without brake)		W	kg	10.62	10.36	10.36	10.36	15.31	15.31	15.28	15.28	20.64	20.64	20.64	20.64
Thermal Resistance ⁽²⁾		K _{therm}	C°/W	1.12	0.77	0.98	0.60	0.87	0.54	0.81	0.42	0.77	0.47	0.59	0.32
Mech. Time Constant		K _{mech}	ms	2.45	2.43	2.47	2.46	1.59	1.60	1.32	1.32	1.36	1.36	1.37	1.37
Motor Constant		K _m	Nm/VW	0.83	0.90	0.84	0.96	1.45	1.71	1.60	2.13	1.91	2.28	1.91	2.98
FEEDBACK	Pole Number	n	10												
	Input Voltage	V _{rms}	4												
	Frequency	kHz	5												
	Input Current	mA	26												
	Transformation Ratio		0.5±10%												
	Null Voltage	mV _{max}	30												
	Phase Shift	Deg	-8°±2°												

1. All performance and electrical specifications are obtained at 25°C ambient and may change ±10%. 2. Rated data with reference aluminum plate 300mm x 408mm x 12mm (maximum winding temperature is 120°C). 3. Higher torque and speed values as well as dimensions on request.

LVSM-140 Torque-Speed Curves

Tr: Rated Torque — @Tr 24V - - - @Tr 48V
 Tp: Peak Torque — @Tp 24V - - - @Tp 48V

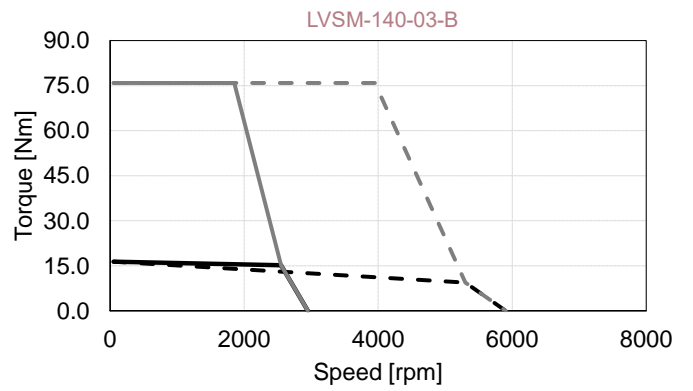
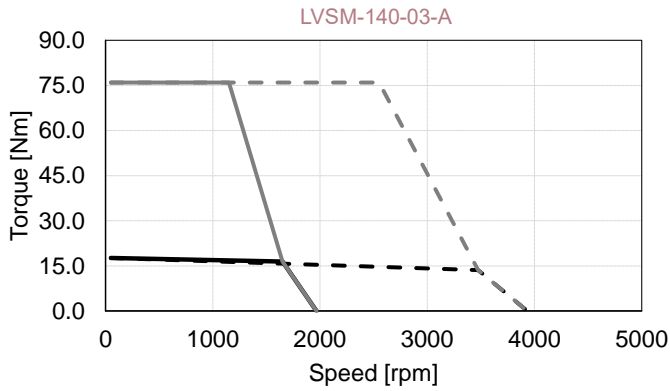
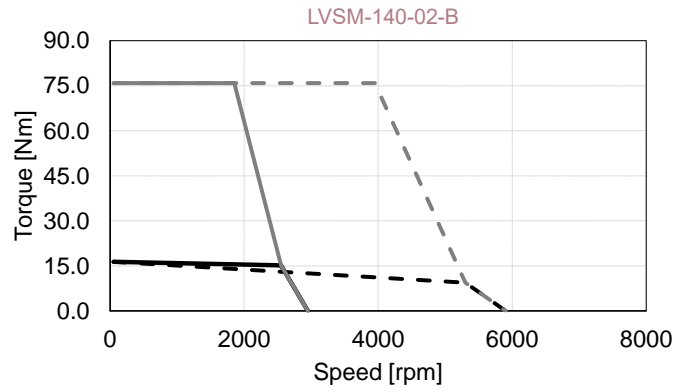
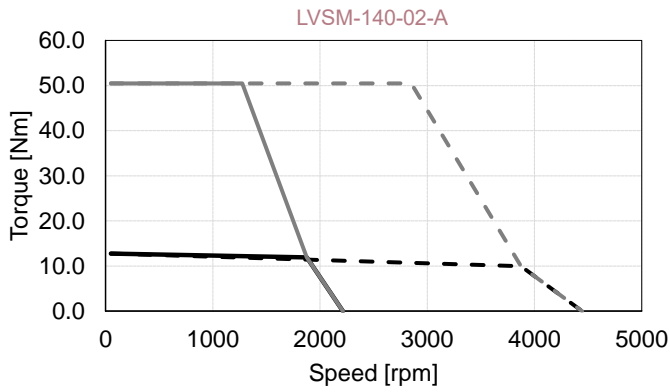
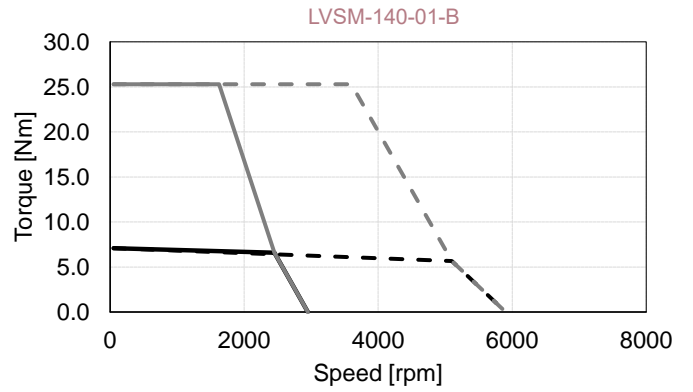
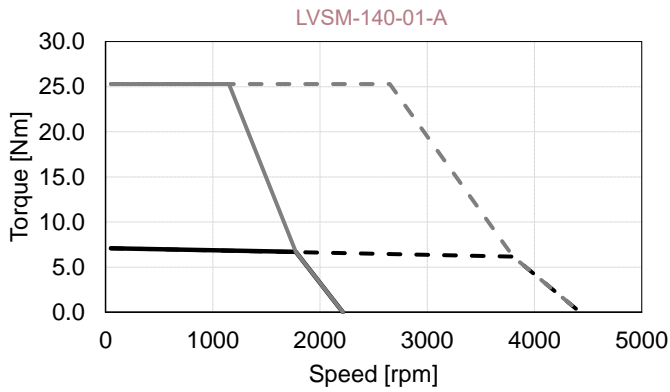

LVSM-140 Outline Drawing

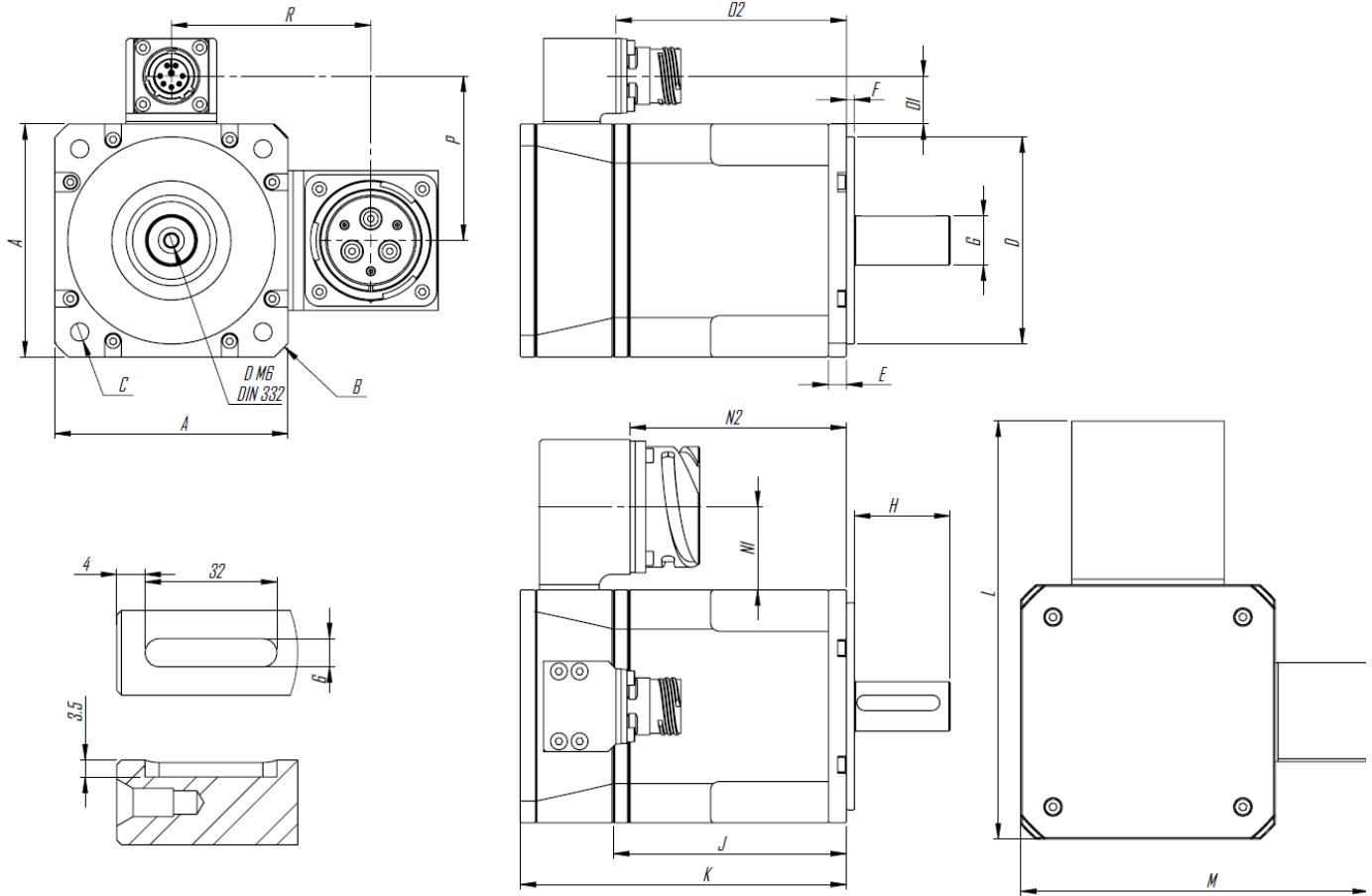

Symbols	Units	Frensiz			Frenli		
		LVSM-140-01	LVSM-140-02	LVSM-140-03	LVSM-140-01	LVSM-140-02	LVSM-140-03
A	mm	140	140	140	140	140	140
B	mm	185	185	185	185	185	185
C	mm	Ø11 on Ø165	Ø11 on Ø165	Ø11 on Ø165	Ø11 on Ø165	Ø11 on Ø165	Ø11 on Ø165
D	mm	Ø130	Ø130	Ø130	Ø130	Ø130	Ø130
E	mm	12	12	12	12	12	12
F	mm	3.5	3.5	3.5	3.5	3.5	3.5
G	mm	Ø32	Ø32	Ø32	Ø32	Ø32	Ø32
J	mm	110	158	206	110	158	206
K	mm	157	205	253	212	260	308
L	mm	208	208	208	208	208	208
M	mm	172	172	172	172	172	172
N1	mm	36	36	36	36	36	36
N2	mm	104	152	200	159	207	255
O1	mm	19	19	19	19	19	19
O2	mm	111	159	207	167	215	263
P	mm	88	88	88	88	88	88
R	mm	106	106	106	106	106	106

Power - Signal Connector

Power Connector (CB2-36-3-PC-FM)

Pin	Function	Description
A	GND	GND
B	B	Phase B
C	-	-
D	C	Phase C
E	-	-
F	A	Phase A

Signal Connector (D38999/20WC8PN)

Pin	Function	Description
A	R1	Ref (+)
B	R2	Ref (-)
C	S1	Cos (+)
D	S3	Cos (-)
E	S2	Sin (+)
F	S4	Sin (-)
G	NTC	Thermal Sensor
H	NTC	Thermal Sensor

Resolver Information

The LVSM series standard servo motors include the resolver as a feedback option. Some important parameters of the resolvers and pin connections used in servo motors can be seen in the table below

Resolver Parameter	Motor Name							
	LVSM-60	LVSM-70	LVSM-80	LVSM-90	LVSM-100	LVSM-115	LVSM-130	LVSM-140
Primary Side	R ₁ -R ₂							
Pole Pairs	1							
Transform. Ratio	0.5±10%							
Voltage Input	5 Vrms				5 Vrms			
Input Current	58 mA				58 mA			
Input Frequency	4.5 kHz				4.5 kHz			
R1-R2 DC Resistance	42 Ω ± 10% (@20°C)				42 Ω ± 10% (@20°C)			
Stator DC Resistance	76 Ω ± 10% (@20°C)				76 Ω ± 10% (@20°C)			

Resolver Schematic and Pin Option

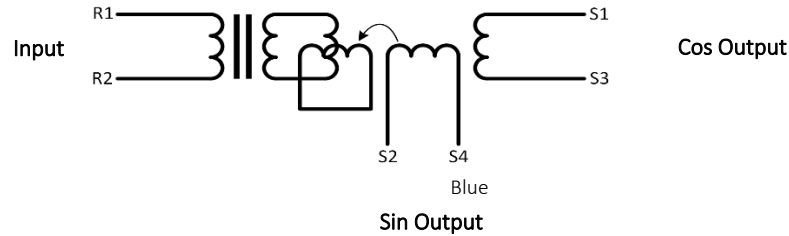

Signal Connector (D38999/20WC8PN)

Pin	Function	Description
A	R1	Ref (+)
B	R2	Ref (-)
C	S1	Cos (+)
D	S3	Cos (-)
E	S2	Sin (+)
F	S4	Sin (-)
G	NTC	Thermal Sensor
H	NTC	Thermal Sensor

Motor Design Sheet

Please send your inquiry to
mds@mdsmotor.com or fax: +90 (262) 341 4472

Contact details	
Company:	
Name:	
Tel:	
Email:	
Application/Project:	

Specifications for motor design

Required torques			
Rated torque [Nm]			
Rated speed [rpm]			
Max. torque [Nm]			
Max speed [rpm]			
Electrical specifications			
DC bus voltage [V]			
Rated current [Arms]			
Max current [Arms]			
Current supply	BLDC / BLAC		
Motor size limits			
Max. diameter allowed [mm]			
Max. length allowed [mm]			
Weight limit if any [kg]			
Inertia req. if any			
Cooling / Construction			
Ambient temp. [oC]			
Housing / cooling type	<input type="checkbox"/> None	<input type="checkbox"/> Air cooled	<input type="checkbox"/> Water cooled
Duty cycle			
Other / Comments			
Rotor type	Surface / IPM / other...		
Torque-speed curve – please draw			
Comments			

Revision No	Version No	Made By	Date
1	V1	OS	10.10.2024



MDS Motor Ltd.

Kocaeli Üniversitesi TEKNOPARK
Vatan Caddesi, No:83 / C:19
41275, Başiskele, Kocaeli, TURKEY

P: +90 (262)-341-4470

F: +90 (262)-341-4472

E-mail: mds@mdsmotor.com

Website: www.mdsmotor.com

MDS Motor © 2024. All rights reserved.

Information in this catalogue is subject to change without previous notice

